



ELECTRONIC AND AVIONICS SYSTEMS

INSTALLATION MANUAL

BENDIX/KING[®]

KX 155/165

*VHF NAV/COMM
TRANSCEIVERS*

*MANUAL NUMBER 006-00179-0006
REVISION 6 OCTOBER, 1994*

WARNING

Information subject to the export control laws. This document, which includes any attachments and exhibits hereto, contains information subject to International Traffic in Arms Regulation (ITAR) or Export Administration Regulation (EAR) of 1979, which may not be exported, released or disclosed to foreign nationals inside or outside the U.S. without first obtaining an export license. Violators of ITAR or EAR may be subject to a penalty of 10 years imprisonment and a fine of \$1,000,000 under 22 U.S.C. 2778 or Section 2410 of the Export Administration Act of 1979. Include this notice with any reproduced portion of this document.

COPYRIGHT NOTICE

©1996 AlliedSignal, Inc.

Reproduction of this publication or any portion thereof by any means without the express written permission of AlliedSignal Commercial Avionics Systems is prohibited. For further information contact the Manager, Technical Publications, AlliedSignal Commercial Avionics Systems, 400 North Rogers Road, Olathe, Kansas, 66062. Telephone: (913) 782-0400.

BENDIX/KING

**KX 155/165
VHF NAV/COMM TRANSCEIVER**

**SECTION I
GENERAL INFORMATION**

1.1	INTRODUCTION	1-1
1.2	EQUIPMENT DESCRIPTION	1-1
1.3	TECHNICAL CHARACTERISTICS	1-2
1.4	UNITS AND ACCESSORIES SUPPLIED	1-8
1.5	ACCESSORIES REQUIRED BUT NOT SUPPLIED	1-11
1.6	LICENSE REQUIREMENTS	1-13
1.7	REQUIREMENTS FOR TSO'D VOR/ILS GLIDESLOPE SYSTEMS	1-13
1.7.1	KX 155/165 GLIDESLOPE INDICATOR REQUIREMENTS	1-13
1.7.2	KX 155 LOCALIZER CONVERTER AND INDICATOR REQUIREMENTS ..	1-14
1.7.3	KX 155 VOR CONVERTER AND INDICATOR REQUIREMENTS	1-14
1.7.4	KX 165 VOR INDICATOR REQUIREMENTS	1-15
1.7.5	KX 165 LOCALIZER INDICATOR REQUIREMENTS	1-16
1.7.6	FULLY TSO'D SYSTEMS	1-17

**SECTION II
GENERAL**

2.1	GENERAL.....	2-1
2.2	UNPACKING AND INSPECTING EQUIPMENT	2-1
2.3	EQUIPMENT INSTALLATION	2-1
2.3.1	AVIONICS COOLING REQ FOR PANEL MOUNTED EQUIPMENT	2-1
2.3.2	MOUNTING RACK INSTALLATION	2-2
2.3.3	ANTENNA INSTALLATION	2-2
2.3.4	CABLE HARNESS AND CONNECTOR ASSEMBLY	2-3
2.3.5	KX 155/165 INSTALLATION	2-4
2.4	POST INSTALLATION CHECK	2-5

BENDIX/KING

**KX 155/165
VHF NAV/COMM TRANSCEIVER**

**SECTION III
OPERATION**

3.1	GENERAL	3-1
3.1.1	COMM TRANSCEIVER	3-1
3.1.2	NAV RECEIVER	3-2
3.2	INDICATOR CONTROLS AND FUNCTIONS	3-4
3.2.1	VOR OPERATION	3-4
3.2.2	LOC OPERATION	3-4
3.2.3	GLIDESLOPE OPERATION	3-4
3.2.4	UNIT CONTROL FUNCTIONS	3-4
3.3	KI 525A INDICATOR CONTROLS AND FUNCTIONS	3-6
3.3.1	VOR/LOC AND GLIDESLOPE OPERATION	3-6
3.4	KNI 229 RMI OPERATION	3-7
3.5	KPI 552 PICTORIAL NAVIGATION INDICATOR	3-7
3.6	KPI 553A PICTORIAL NAVIGATION INDICATOR	3-9
3.6.1	KPI 553A (Figure 3-6)	3-10

LIST OF ILLUSTRATIONS

FIGURE		PAGE
2-1	MOLEX TERMINAL AND TOOLS	2-6
2-2	CONNECTOR ASSEMBLY (030-00101-0002).....	2-9
2-3	KX 155/165 OUTLINE AND MOUNTING DRAWING	2-11
2-4	KX 155/165 INSTALLATION ASSEMBLY DRAWING	2-13
2-5	KX 155 NAV/COMM TRANSCEIVER	2-17
2-6	KX 165 NAV/COMM VOR/LOC CONVERTER W/GS OPTION	2-19
2-7	KX 155 NAV/COMM TRANSCEIVER WITH AUDIO AMP OPTION	2-21
2-8	KX 155 NAV/COMM TRANSCEIVER & GS OPTION	2-23
2-9	KX 165 NAV/COMM VOR/LOC CONV & GS OPTION	2-25
2-10	PARTIAL INTCNT FOR DUAL KX 155/165 (KN 62A/64).....	2-27
2-11	PARTIAL INTCNT FOR DUAL KX 155/165 (W/O OBS RESOLVER)....	2-29
2-12	PARTIAL INTCNT FOR DUAL KX 155/165 (KX 170A/B, KX175A/B)..	2-31
2-13	PARTIAL INTCNT FOR DUAL KX 155/165 (KNS 81).....	2-33
3-1	KX 155/165 CONTROL FUNCTION	3-3
3-2	TYPICAL INDICATOR MARKINGS	3-5
3-3	KI 525A INDICATOR AND CONTROLS	3-6
3-4	KNI 229 RADIO MAGNETIC INDICATOR	3-7
3-5	KPI 552 PICTORIAL NAVIGATION INDICATOR	3-8
3-6	KPI 553A PICTORIAL NAVIGATION INDICATOR	3-11

BENDIX/KING**KX 155/165
VHF NAV/COMM TRANSCEIVER****SECTION I
GENERAL INFORMATION****1.1 INTRODUCTION**

This manual contains information relative to the physical, mechanical, and electrical characteristics of the Bendix/King Silver Crown KX 155/165 VHF COMM Transceiver/Navigation/VOR/LOC Glideslope Receiver. Installation and operating procedures are also included.

Information relative to the maintenance, alignment, and procurement of replacement parts may be found in the KX 155/165 Maintenance/Overhaul Manual, P/N 006-05179-XXXX.

1.2 EQUIPMENT DESCRIPTION

The KX 155/165 is a VHF NAV/COMM Transceiver which provides the following functions.

- A. Two-way voice communication within the frequency range of 118.00 Hz to 135.975 MHz (720 Channels) or 118.00 Hz to 136.975 MHz (760 Channels) in 25 kHz increments.
- B. Reception of navigation signals within the frequency range of 108.00 MHz to 117.95 MHz in 50 kHz increments (200 channel).
- C. Optional reception of glideslope signals within the frequency range of 329.15 MHz to 335.00 MHz in 150 kHz increments (40 channel).
- D. VOR/LOC signal converter. (Not available on the KX 155)

The KX 155/165 is a panel mounted unit. Connections to the unit are made through one 30 and one 36 pin Molex printed circuit board edge connector and three BNC coax connectors at the rear of the unit.

Electrically, the KX 155/165 consists of the following sections:

- A. COMM Transmitter
- B. COMM Receiver
- C. COMM Frequency Synthesizer
- D. NAV Receiver

BENDIX/KING

**KX 155/165
VHF NAV/COMM TRANSCEIVER**

- E. NAV Frequency Synthesizer
- F. Glideslope Receiver and Converter (Optional)
- G. Glideslope Frequency Synthesizer (Optional)
- H. VOR/LOC Converter (Not available in the KX 155)
- I. Gas Discharge Display
- J. Microprocessor
- K. Switching Power Supply
- L. 4 ohm Audio Amplifier

1.3 TECHNICAL CHARACTERISTICS

KX 155/165

TSO COMPLIANCE:

TSO
RTCA DO-160 Env Cat
A1D1/A/KPS/XXXXXXZBAAA

ICAO ANNEX 10 ON FM BROADCAST
INTERFERENCE IMMUNITY
Post Mod 16 Only

ICAO ANNEX 10
COMM - Paragraph 4.7.3
ILS - Paragraph 3.1.4
VOR - Paragraph 3.3.8

TEMPERATURE RANGE:

-20°C to +55°C with short time operation at
+70°C.

ALTITUDE:

-15,000 feet to 50,000 feet

WEIGHT:

KX 155	VERSIONS	136 MHz VERSIONS	WEIGHT
	069-1024-00	069-1024-30	4.75 lbs. (2.15 kg)
	069-1024-01	069-1024-31	5.30 lbs. (2.40 kg)
	069-1024-02	069-1024-32	4.75 lbs. (2.15 kg)
	069-1024-03	069-1024-33	5.30 lbs. (2.40 kg)
	069-1024-04	069-1024-34	4.75 lbs. (2.15 kg)
	069-1024-05	069-1024-35	5.30 lbs. (2.40 kg)
	069-1024-06	069-1024-36	4.75 lbs. (2.15 kg)
	069-1024-07	069-1024-37	5.30 lbs. (2.40 kg)
	069-1024-08	069-1024-38	4.95 lbs. (2.24 kg)
	069-1024-09	069-1024-39	4.95 lbs. (2.24 kg)
	069-1024-10	069-1024-40	4.95 lbs. (2.24 kg)
	069-1024-11	069-1024-41	4.95 lbs. (2.24 kg)
	069-1024-12	069-1024-42	5.50 lbs. (2.49 kg)
	069-1024-13	069-1024-43	5.50 lbs. (2.49 kg)
	069-1024-20		4.75 lbs. (2.15 kg)

BENDIX/KING

KX 155/165
VHF NAV/COMM TRANSCEIVER

KX 165	VERSIONS	136 MHz VERSIONS	WEIGHT
	069-1025-00	069-1025-20	5.10 lbs. (2.31 kg)
	069-1025-01	069-1025-21	5.65 lbs. (2.56 kg)
	069-1025-02	069-1025-22	5.10 lbs. (2.56 kg)
	069-1025-03	069-1025-23	5.65 lbs. (2.56 kg)
	069-1025-04	069-1025-24	5.10 lbs. (2.31 kg)
	069-1025-05	069-1025-25	5.65 lbs. (2.31 kg)
	069-1025-06	069-1025-26	5.10 lbs. (2.31 kg)
	069-1025-07	069-1025-27	5.65 lbs. (2.56 kg)

PHYSICAL DIMENSIONS:

Width: 6.25 inches (15.875 cm)
 Height: 2.05 inches (5.207 cm)
 Depth: 10.16 inches (25.81 cm) to end of connector

MOUNTING: Panel mounted, no shock mounting required

POWER CONSUMPTION:

KX 155: +27.5 Vdc	RECEIVE: 0.4 A max
KX 165: +27.5 Vdc	TRANSMIT: 6.0 A max
KX 155: +13.75 Vdc	RECEIVE: 0.7 A max
KX 165: +13.75 Vdc	TRANSMIT: 8.5 A max

COMM TRANSCEIVER

TSO COMPLIANCE:

Transmit: C37b (DO-157, Class 4)
 Receive: C38b (DO-156, Class C & D)
 C38b (DO-156, Class A) 50 kHz Selectivity

APPLICABLE DOCUMENTS: RTCA DO-156, DO-157, DO-160

ICAO ANNEX 10 ON FM BROADCAST INTERFERENCE IMMUNITY Post Mod 16 Only	ICAO ANNEX 10 Paragraph 4.7.3 RTCA DO-186 Paragraph 2.2.10 Intermodulation Paragraph 2.2.11 Desensitization ED-23A Section 3.1.10 Intermodulation ED-23A Section 3.1.11 Desensitization
--	---

DUTY CYCLE: 10%, 4.5 minutes receive, 0.5 minutes transmit

FREQUENCY RANGE: 118.000 MHz to 135.975 MHz or 136.975 MHz in 25 kHz increments

FREQUENCY TOLERANCE: 0.0015% to meet DO-156 Class C & D

UP793797

BENDIX/KING

KX 155/165
VHF NAV/COMM TRANSCEIVER

COMM TRANSMITTER

POWER OUTPUT: 10 watts minimum

MODULATION: 85% modulation capability with 90% limiting, less than 15% distortion at 85% modulation. Audio leveling circuit used.

SIDETONE OUTPUT: Adjustable up to 100 mW into 500 ohm headphones

MICROPHONE: Standard carbon or dynamic mic containing transistorized pre-amp. (Must provide 100 mVrms into 100 ohm load.)

HARMONIC CONTENT: Greater than 60 dB down from carrier

HIGH TEMPERATURE PROTECTION: If the transmitter and modulator circuits become hot enough to potentially damage any components in the transceiver, a protection circuit will automatically reduce the transmitter power consumption and output power.

COMM RECEIVER

RECEIVER SENSITIVITY: 2 μ V (hard) or less (typically 1 μ V) for 6 dB S + N/N with 1,000 Hz tone modulated 30%.

RECEIVER SELECTIVITY:

KX 155/165 25 kHz SEL: 6 dB bandwidth \pm 8.1 kHz
60 dB bandwidth \pm 20.0 kHz

KX 155/165 50 kHz SEL: 6 dB bandwidth \pm 14.5 kHz
60 dB bandwidth \pm 43 kHz

RECEIVER AUDIO OUTPUT: 100 mW into 500 ohms minimum. Audio leveling circuit attacks at less than 15% modulation.

AGC CHARACTERISTICS: From 5 μ V to 20,000 μ V audio output will not vary more than 3 dB. Active from no signal to +6 dBm hard.

BENDIX/KING

**KX 155/165
VHF NAV/COMM TRANSCEIVER**

SQUELCH: Automatic squelch (internally adjustable carrier to noise setting) with manual disable and carrier squelch override. Both squelch adjustments are externally accessible.

SPURIOUS RESPONSE AND CROSS MODULATION PRODUCTS: At least 80 dB down

INTERCOM INPUT: The mic is connected to the intercom input. The receiver is operational and mic audio appears at the audio output along with received audio. 50 mV of mic audio is required for 100 mW output.

NAV RECEIVER

TSO COMPLIANCE: C36c (DO-131, Class D)
C40a (DO-153, CAT A and B)

APPLICABLE DOCUMENTS: RTCA DO-131, RTCA DO-153, RTCA DO-160, RTCA DO-195 and RTCA DO-196.

ICAO ANNEX 10 on FM BROADCAST INTERFERENCE IMMUNITY Post Mod 16 Only: Paragraph 3.1.4 (ILS)
Paragraph 3.3.8 (VOR)
RTCA DO-195 (ILS)
Paragraph 2.2.2.4 Intermodulation
Paragraph 2.2.6 Desensitization
RTCA DO-196 (VOR)
Paragraph 2.2.2.3 Intermodulation
Paragraph 2.2.8 Desensitization

FREQUENCY RANGE: 108.00 MHz to 117.95 MHz in 50 kHz increments

FREQUENCY TOLERANCE: 0.0015% to meet DO-153, CAT A and B

VOR/LOC SENSITIVITY: 1/2 flag sensitivity 2 μ V (hard) or less (typically 1 μ V) on all channels

RECEIVER SELECTIVITY: 6 dB bandwidth shall be not less than 16.0 kHz on each side.
60 dB bandwidth shall be not less than 31.5 kHz on each side.

SPURIOUS RESPONSES AND CROSS MODULATION PRODUCTS: At least 80 dB down

BENDIX/KING**KX 155/165
VHF NAV/COMM TRANSCEIVER**

VOR COURSE ACCURACY: Two sigma limit 3° as specified in RTCA DO-153

VOR/AGC CHARACTERISTICS: Less than 1° change with $10 \mu\text{V}$ to $20,000 \mu\text{V}$ standard OMNI test signals. Active from half flag to +6 dBm hard.

AUDIO OUTPUT: With a 1 kHz tone 30% modulation at least 100 mW output into 500 ohm loads

IDENT/VOICE: With $100 \mu\text{V}$ input, 30% modulation at 1020 Hz, the ident/voice tone ratio shall not be less than 15 dB

AUDIO RESPONSE: Less than 6 dB variation from 350 Hz to 2500 Hz

AGC CHARACTERISTICS: From $5 \mu\text{V}$ to $20,000 \mu\text{V}$ audio output will not vary more than 3 dB

LOC CENTERING ERROR: Two sigma limit $\pm 7 \mu\text{A}$ as specified in RTCA DO-131

GLIDESLOPE RECEIVER

TSO COMPLIANCE: C34c (DO-132, Category II, Class D)

APPLICABLE DOCUMENTS: RTCA DO-132, DO-160

CENTERING ACCURACY: Centering accuracy of less than $\pm 10 \mu\text{A}$ under all service conditions (operating performance Category II, Class D).

DEFLECTION CHARACTERISTICS: A difference in depth of modulation of 0.091 ddm, or 2 dB, shall produce a deflection of $78 \mu\text{A}$ (typical). The deviation under opposite polarity shall be $78 \pm 3 \mu\text{A}$ (typical).

FREQUENCY RANGE: 329.15 MHz to 335.00 MHz 40 channels (150 kHz spacing).

STABILITY: 0.0015%

SENSITIVITY: $20 \mu\text{V}$ or less for 60% of standard deflection

BENDIX/KING**KX 155/165
VHF NAV/COMM TRANSCEIVER**

SELECTIVITY: Less than 6 dB variation when frequency is varied ± 21 kHz. At least 60 dB down from 329.00 MHz to 335.30 MHz excluding the range from ± 129 kHz of center frequency.

SPURIOUS RESPONSE: All responses in the range from 90 kHz to 1500 MHz at least 60 dB below center frequency response, excluding the range from 329.00 MHz to 335.30 MHz.

LOADS: Capable of operating one to eight 1000 ohm deviation loads and nine 1000 ohm alarm flag loads. No load resistors are required.

VOR/LOC CONVERTER

TSO COMPLIANCE: C40a (D0-153, Class I and II)
C36c (D0-131, Class D)

ACCURACY:

VOR: Typical bearing error of less than 0.5° with precision track selector (2° max. error).

LOC: Typical centering error of less than $3 \mu\text{A}$ ($7 \mu\text{A}$ max. error).

COURSE WIDTH:

VOR: $10^{\circ} \pm 1^{\circ}$ externally adjustable

LOC: $90 \mu\text{A} \pm 5 \mu\text{A}$ for ddm of 0.093 ddm or 4 dB

INPUT IMPEDANCE: 60 K Ω for 0.5 Vrms input (VOR mode)

LOADS: Five 1000 ohm deviation loads, three 1000 ohm flag loads and three 200 ohm to-from loads

AUDIO AMP

4 ohm Output: 4 watts minimum (13.75 volts)
8 watts minimum (27.5 volts)

Inputs: 2-500 ohm Auxiliary Inputs

BENDIX/KING**KX 155/165
VHF NAV/COMM TRANSCEIVER****1.4 UNITS AND ACCESSORIES SUPPLIED****1.4.1 KX 155/165**

The Bendix/King KX 155/165 Transceivers with mounting rack (P/N 047-04874-0001) are available in the following configurations:

Part Number	RDL FCTN	GS RCVR	VOR/ LOC	ISO AMP	14 VOLT	28 VOLT	50 KHZ SELECT	136 MHZ OPTIONS	NIGHT VISION GOGGLES
069-1024-00					X				
069-1024-01		X			X				
069-1024-02					X		X		
069-1024-03		X			X		X		
069-1024-04						X			
069-1024-05		X				X			
069-1024-06						X	X		
069-1024-07		X				X	X		
069-1024-08				X	X				
069-1024-09				X		X			
069-1024-10				X	X		X		
069-1024-11				X		X	X		
069-1024-12		X		X	X				
069-1024-13		X		X			X		
069-1024-20						X	X		X
069-1024-30					X			X	
069-1024-31		X			X			X	
069-1024-32					X		X	X	
069-1024-33		X			X		X	X	
069-1024-34						X		X	

BENDIX/KING

**KX 155/165
VHF NAV/COMM TRANSCEIVER**

KX 155 Available Configurations (con't)

Part Number	RDL FCTN	GS RCVR	VOR/ LOC	ISO AMP	14 VOLT	28 VOLT	50 KHZ SELECT	136 MHZ OPTIONS	NIGHT VISION GOGGLES
069-1024-35		X				X		X	
069-1024-36						X	X	X	
069-1024-37		X				X	X	X	
069-1024-38				X	X			X	
069-1024-39				X		X		X	
069-1024-40				X	X		X	X	
069-1024-41				X		X	X	X	
069-1024-42		X		X	X			X	
069-1024-43		X		X		X		X	

BENDIX/KING

**KX 155/165
VHF NAV/COMM TRANSCEIVER**

KX 165 Available Configurations

Part Number	RDL FCTN	GS RCVR	VOR/ LOC	ISO AMP	14 VOLT	28 VOLT	50 KHZ SELECT	136 MHZ OPTIONS	NIGHT VISION GOGGLES
069-1025-00	X		X		X				
069-1025-01	X	X	X		X				
069-1025-02	X		X		X		X		
069-1025-03	X	X	X		X		X		
069-1025-04	X		X			X			
069-1025-05	X	X	X			X			
069-1025-06	X		X			X	X		
069-1025-07	X	X	X			X	X		
069-1025-20	X		X		X			X	
069-1025-21	X	X	X		X			X	
069-1025-22	X		X		X		X	X	
069-1025-23	X	X	X		X		X	X	
069-1025-24	X		X			X		X	
069-1025-25	X	X	X			X		X	
069-1025-26	X		X			X	X	X	
069-1025-27	X	X	X			X	X	X	

BENDIX/KING

KX 155/165
VHF NAV/COMM TRANSCEIVER

1.4.2 INSTALLATION KIT

Bendix/King KX 155/165 Installation Kit (P/N 050-1778-00/01/02/03), contains the following parts:

SYMBOL	PART NUMBER	DESCRIPTION	A	UM	00	01	02	03
	050-01778-0000	INKT W/GS & W/VOR	KX	0165	X			
	050-01778-0001	INKT WO/GS & W/VOR	KX	0165		X		
	050-01778-0002	INKT W/GS & WO/VOR	KX	0155			X	
	050-01778-0003	INKT WO/GS & WO/VOR	KX	0155				X
	030-01107-0020	CONNECTOR TERM 20T	EA		.	.	.	1.00
	030-01107-0040	CONNECTOR TERM 40T	EA		.	.	1.00	.
	030-01107-0054	CONNECTOR TERM 54T	EA		.	1.00	.	.
	030-01107-0064	CONNECTOR TERM 64T	EA		1.00	.	.	.
	047-05959-0002	STRAIN RELIEF W/H	A	EA	2.00	2.00	2.00	2.00
	047-05960-0001	STRAIN RELIEF W/F	A	EA	2.00	2.00	2.00	2.00
	073-00431-0003	CONN PLT CSTG	A	EA	1.00	1.00	1.00	1.00
	089-02051-0024	NUT SPEED U 6-32	EA		4.00	4.00	4.00	4.00
	089-02353-0001	NUT CLIP 6-32	EA		6.00	6.00	6.00	6.00
	089-05878-0005	SCR PHP 4-40X5/16	EA		2.00	2.00	2.00	2.00
	089-05878-0010	SCR PHP 4-40X5/8	EA		4.00	4.00	4.00	4.00
	089-05907-0006	SCR PHP 6-32X3/8	EA		4.00	4.00	4.00	4.00
	089-06012-0008	SCR FHP 6-32X1/2	EA		6.00	6.00	6.00	6.00
	090-00019-0007	RING RTNR .438	EA		3.00	2.00	3.00	2.00
P 301	030-00101-0002	PANEL MOUNT PLUG	EA		1.00	1.00	1.00	1.00
P 401	030-01094-0059	CONN 15 POS	EA		1.00	1.00	1.00	1.00
P 801	030-00101-0002	PANEL MOUNT PLUG	EA		1.00	1.00	1.00	1.00
P 901	030-01094-0060	CONN 18 POS	EA		1.00	1.00	1.00	.
P 902	030-00101-0002	PANEL MOUNT PLUG	EA		1.00	.	1.00	.

1.5 ACCESSORIES REQUIRED BUT NOT SUPPLIED

- A. Broad band 50 ohm vertically polarized Communications antenna with coaxial cable.
- B. Headphones: 500 ohms nominal impedance.
- C. Microphone: Low impedance carbon or dynamic with transistorized pre-amp.
- D. Broad band 50 ohm horizontally polarized Navigation antenna with coaxial cable.
- E. Broad band 50 ohm horizontally polarized Glideslope antenna with coaxial cable or low loss spiltter used with the navigation antenna.

BENDIX/KING

**KX 155/165
VHF NAV/COMM TRANSCEIVER**

- F. VOR, LOC, Glideslope Indicators. Various Bendix/King options include:
1. KI 203/208 Indicator (VOR/LOC only)
 2. KI 204/206/209 ILS Indicator (VOR/LOC Glideslope)
 3. KNI 520 Navigation Indicator (VOR/LOC Glideslope)
 4. KPI 553A Pictorial Navigation System
 5. KI 525/525A (VOR/LOC Glideslope)
 6. KI 229 RMI
 7. KI 202 (VOR/LOC Only)
 8. KPI 552 Pictorial Navigation Indicator

G. In some installations it may be desirable to allow the Glideslope Receiver to operate using the aircraft's navigation antenna. In other installations it may be desirable to operate two NAV/LOC Receivers or two GS Receivers using a common antenna. Low-loss couplers are available to allow such operation.

An overall degradation in sensitivity will be realized due to the insertion loss of the coupler. The installer must verify that acceptable sensitivity and proper system performance is realized in a system that utilizes a coupler. A minimum of 20 dB of GS receiver-to-receiver isolation is required in dual installations employing a KX 155 or KX 165 GS receiver.

Examples of some common couplers are listed below. Contact the coupler manufacturer for specifications for the couplers listed.

Coupler to allow one antenna to operate:	Dayton-Granger (305)463-3451	Dorne Margolin (516)585-4000
One Nav and one GS	GSNC 20-05	H22-1
Two Navs	DRC 20-04 Or 14830	H21-1
Two Glideslopes	DGSC 20-02 or 16009	H24-1
Two Navs and two GSs	DOC 20-06 or 16010	H69-1

BENDIX/KING

KX 155/165
VHF NAV/COMM TRANSCEIVER

1.6 LICENSE REQUIREMENTS

The Federal Communications Commission requires that the operator of the transmitter of this equipment hold a restricted radio telephone operators permit (FCC Form 753) or higher class license. A permit may be obtained by a U.S. citizen from the nearest field office of the FCC; no examination is required.

This equipment has been accepted by FCC and entered on their list of type accepted equipment as Bendix/King KX 155, or KX 165 and must be identified as Bendix/King KX 155, or KX 165.

CAUTION

THE VHF TRANSMITTER IN THIS EQUIPMENT IS GUARANTEED TO MEET FEDERAL COMMUNICATIONS COMMISSION ACCEPTANCE OVER THE OPERATING TEMPERATURE RANGE ONLY WHEN A BENDIX/KING CRYSTAL IS USED IN THE STABILIZED MASTER OSCILLATOR.

USE OF OTHER THAN A BENDIX/KING CRYSTAL IS CONSIDERED AN UNAUTHORIZED MODIFICATION, AND WILL VOID THE WARRANTY.

An Aircraft Station License is required for this equipment. Forms (FCC Form 404, New Aircraft Station License, or FCC Form 405A, Renewal of Aircraft Station License) can be obtained from your nearest FCC Field Office.

1.7 REQUIREMENTS FOR TSO'D VOR/ILS GLIDESLOPE SYSTEMS

The additional units used in conjunction with the KX 155/165 must meet the specifications listed below to comprise a completely TSO'd navigation system.

1.7.1 KX 155/165 GLIDESLOPE INDICATOR REQUIREMENTS

- A. The indicator shall meet all applicable requirements of TSO C34c.
- B. Centering current to be $0 \pm 6.6 \mu\text{A}$ with a 95% probability under all environmental conditions listed in RTCA Paper DO-132, Minimum Performance Standards -- Airborne ILS Glideslope Receiving Equipment, Paragraph 2.1, sub-paragraph B, Centering Accuracy.
- C. The course deviation pointer shall visibly deflect at least $\pm 5/8$ inch along its scale when the input current is changed from zero to $\pm 150 \mu\text{A}$.
- D. Deflection linearity over the deflection range from zero to $150 \mu\text{A}$ shall be within 10% of being proportional to the input current. Additionally, as the current is increased beyond that producing full scale deflection to a value of $\pm 685.7 \mu\text{A}$, the indicator deflection shall not decrease.

BENDIX/KINGKX 155/165
VHF NAV/COMM TRANSCEIVER

- E. When the input current is abruptly changed from any value from zero to $\pm 150 \mu\text{A}$, the pointer shall reach 67% of its ultimate deflection within 2 seconds and pointer overshoot shall not exceed 5%.
- F. The input impedance shall be 1 K ohms $\pm 5\%$ for both the deviation indicator and warning signal.
- G. A warning signal input current of 150 μA or less shall produce a fully visible warning flag. A warning signal input current of 260 μA or greater shall produce a fully concealed warning flag.

1.7.2 KX 155 LOCALIZER CONVERTER AND INDICATOR REQUIREMENTS

- A. The indicator shall meet all applicable requirements of C36c.
- B. Centering current to be $0 \pm 6.0 \mu\text{A}$ with a 95% probability under all environmental conditions listed in RTCA Paper DO-131, Minimum Performance Standards -- Airborne ILS Localizer Receiving Equipment, Paragraph 2.1, sub-paragraph b, Centering Accuracy.
- C. The course deviation pointer shall visibly deflect at least $\pm 3/8$ inch along its scale when the input current is changed from zero to $\pm 90 \mu\text{A}$.
- D. Deflection linearity over the deflection range from zero to $\pm 90 \mu\text{A}$ shall be within 10% of being proportional to the difference in depth of modulation of the 90 and 150 Hz signals, or the deflection shall be within 5% of standard deflection ($\pm 90 \mu\text{A}$) of being proportional to the difference in depth of modulation, whichever is greater.

Additionally, as the difference in depth of modulation is increased beyond that producing full scale deflection ($\pm 150 \mu\text{A}$) to a value of 0.4 ddm, the course deviation pointer deflection shall not decrease.

- E. When the input current is abruptly changed from zero to $\pm 150 \mu\text{A}$, the pointer shall reach 67% of its ultimate deflection within 2 seconds and pointer overshoot shall not exceed 5%.
- F. The input impedance of the indicator for both the deviation indicator and warning signal shall be 1 K Ω $\pm 5\%$.
- G. A warning signal input current of 125 μA or less shall produce a fully visible warning flag. A warning signal input current of 260 μA or greater shall produce a fully concealed warning flag.

1.7.3 KX 155 VOR CONVERTER AND INDICATOR REQUIREMENTS

- A. The indicator shall meet all applicable requirements of TSO C40a.

BENDIX/KINGKX 155/165
VHF NAV/COMM TRANSCEIVER

- B. The bearing error shall be less than 2.5° with a 95% probability under all environmental conditions listed in RTCA Paper DO-153, Minimum Performance Standards -- Airborne VOR Receiving Equipment, Paragraph 2.1, sub-paragraph 2.1.2, Bearing Accuracy.

NOTE: For older equipment, the Bearing Error shall be less than 2.7° with a 95% probability under all environmental conditions listed in RTCA Paper DO-114, MINIMUM PERFORMANCE STANDARDS -- AIRBORNE VOR RECEIVING EQUIPMENT, Paragraph 2.1, Sub-paragraph B, BEARING ACCURACY.

- C. The course deviation pointer shall visibly deflect at least $\pm 1/2$ inch (for DO-153) or $3/8$ inch (for DO-114) along its scale when the input current is changed from zero to $\pm 150 \mu\text{A}$.

- D. Deflection Linearity

The deflection shall be proportional to the change in phase between the two components of the standard VOR test signal, within 20% of the deflection produced by a 10° ($\pm 150 \mu\text{A}$) change in phase. This requirement shall be met at all deflections produced when the phase difference is varied from plus 10° to minus 10° of that producing an "on course" indication.

The pointer deflection shall not decrease as the phase difference is increased from the producing an "on course" indication to that producing an indication which is equivalent to $\pm 80^{\circ}$ from "on course".

- E. Deflection Response

When the difference in phase between the two components of an "on course" standard VOR test signal is abruptly changed, the pointer shall reach 70% of its ultimate position within 3 seconds and the pointer overshoot shall not exceed 20%.

- F. The input impedance of the indicator for both the bearing error and warning signal shall be $1 \text{ K}\Omega \pm 5\%$.

- G. A warning signal input current of $125 \mu\text{A}$ or less shall produce a fully visible warning flag. A warning signal input current of $266 \mu\text{A}$ or greater shall produce a fully concealed warning flag.

- H. The input impedance of the TO/FROM indicator shall be 200 ohms $\pm 200 \mu\text{A}$ sensitivity.

1.7.4 KX 165 VOR INDICATOR REQUIREMENTS

- A. The indicator shall meet all applicable requirements of TSO C40a.

BENDIX/KINGKX 155/165
VHF NAV/COMM TRANSCEIVER

- B. The bearing error shall be less than 1.9° with a 95% probability under all environmental conditions listed in RTCA Paper DO-153, Minimum Performance Standards -- Airborne VOR Receiving Equipment, Paragraph 2.1, sub-paragraph 2.1.2, Bearing Accuracy.

NOTE: For older equipment, the Bearing Error shall be less than 2.7° with a 95% probability under all environmental conditions listed in RTCA Paper DO-114, MINIMUM PERFORMANCE STANDARDS -- AIRBORNE VOR RECEIVING EQUIPMENT, Paragraph 2.1, Sub-paragraph B, BEARING ACCURACY.

- C. The course deviation pointer shall visibly deflect at least $\sim 1/2$ inches (for DO-153) for $3/8$ inch (for DO-114) along its scale when the input current is changed from zero to $\pm 150 \mu\text{A}$.

- D. Deflection Linearity

The deflection shall be proportional to the change in phase between the two components of the standard VOR test signal, within 20% of the deflection produced by a 10° ($\pm 150 \mu\text{A}$) change in phase. This requirement shall be met at all deflections produced when the phase difference is varied from plus 10° to minus 10° of that producing an "on course" indication.

The pointer deflection shall not decrease as the phase difference is increased from the producing an "on course" indication to that producing an indication which is equivalent to $\pm 80^{\circ}$ from "on course".

- E. Deflection Response

When the difference in phase between the two components of an "on course" standard VOR test signal is abruptly changed, the pointer shall reach 70% of its ultimate position within 3 seconds and the pointer overshoot shall not exceed 20%.

- F. The input impedance of the indicator for both the bearing error and warning signal shall be $1 \text{ K}\Omega \pm 5\%$.

- G. A warning signal input current of $125 \mu\text{A}$ or less shall produce a fully visible warning flag. A warning signal input current of $266 \mu\text{A}$ or greater shall produce a fully concealed warning flag.

- H. The input impedance of the TO/FROM indicator shall be 200 ohms $\pm 200 \mu\text{A}$ sensitivity.

1.7.5 KX 165 LOCALIZER INDICATOR REQUIREMENTS

- A. The indicator shall meet all applicable requirements of C36c.

BENDIX/KINGKX 155/165
VHF NAV/COMM TRANSCEIVER

- B. The localizer centering current to be $0 \pm 3.2 \mu\text{A}$ with a 95% probability under all environmental conditions listed in RTCA DO-131, Minimum Performance Standards -- Airborne ILS Localizer Receiving Equipment, Paragraph 2.1, sub-paragraph B, Centering Accuracy.
- C. The course deviation pointer shall visibly deflect at least $\pm 3/8$ inch along its scale when the input current is changed from zero to $\pm 90 \mu\text{A}$.
- D. Deflection linearity over the range from zero to $\pm 90 \mu\text{A}$ shall be within 10% of being proportional to the difference in depth of modulation of the 90 and 150 Hz signals, or the deflection shall be within 5% of standard deflection ($\pm 90 \mu\text{A}$) of being proportional to the difference in depth of modulation, whichever is greater.

Additionally, as the difference in depth of modulation is increased beyond that producing full scale deflection ($\pm 150 \mu\text{A}$) to a value of 0.4 ddm, the course deviation pointer deflection shall not decrease.

- E. When the input current is abruptly changed from zero to $\pm 150 \mu\text{A}$, the pointer shall reach 67% of its ultimate deflection within 2 seconds and pointer overshoot shall not exceed 5%.
- F. The input impedance of the indicator for both the deviation indicator and warning signal shall be $1 \text{ K}\Omega \pm 5\%$.
- G. A warning signal input current of $125 \mu\text{A}$ or less shall produce a fully visible warning flag. A warning signal input current of $260 \mu\text{A}$ or greater shall produce a fully concealed warning flag.

1.7.6 FULLY TSO'D SYSTEMS

- A. The following systems when used in conjunction with the KX 165 will meet all TSO system requirements:
1. KI 206
 2. KI 525A
 3. KPI 552
 4. KPI 553A
 5. KI 202
- B. The following systems when used in conjunction with the KX 155 will meet all TSO system requirements.
- | | |
|-----------|-------------------|
| 1. KI 203 | 5. KN 72, KI 206 |
| 2. KI 204 | 6. KN 72, KI 525A |
| 3. KI 208 | 7. KN 72, KPI 552 |
| 4. KI 209 | 8. KN 72, KPI 553 |

BENDIX/KING

**KX 155/165
VHF NAV/COMM TRANSCEIVER**

**SECTION II
GENERAL**

2.1	GENERAL.....	2-1
2.2	UNPACKING AND INSPECTING EQUIPMENT	2-1
2.3	EQUIPMENT INSTALLATION	2-1
2.3.1	AVIONICS COOLING REQ FOR PANEL MOUNTED EQUIPMENT	2-1
2.3.2	MOUNTING RACK INSTALLATION	2-2
2.3.3	ANTENNA INSTALLATION	2-2
2.3.4	CABLE HARNESS AND CONNECTOR ASSEMBLY	2-3
2.3.5	KX 155/165 INSTALLATION	2-4
2.4	POST INSTALLATION CHECK	2-5

LIST OF ILLUSTRATIONS

FIGURE		PAGE
2-1	MOLEX TERMINAL AND TOOLS	2-6
2-2	CONNECTOR ASSEMBLY (030-00101-0002).....	2-9
2-3	KX 155/165 OUTLINE AND MOUNTING DRAWING	2-11
2-4	KX 155/165 INSTALLATION ASSEMBLY DRAWING	2-13
2-5	KX 155 NAV/COMM TRANSCEIVER	2-17
2-6	KX 165 NAV/COMM VOR/LOC CONVERTER W/GS OPTION	2-19
2-7	KX 155 NAV/COMM TRANSCEIVER WITH AUDIO AMP OPTION	2-21
2-8	KX 155 NAV/COMM TRANSCEIVER & GS OPTION	2-23
2-9	KX 165 NAV/COMM VOR/LOC CONV & GS OPTION	2-25
2-10	PARTIAL INTCNT FOR DUAL KX 155/165 (KN 62A/64).....	2-27
2-11	PARTIAL INTCNT FOR DUAL KX 155/165 (W/O OBS RESOLVER)....	2-29
2-12	PARTIAL INTCNT FOR DUAL KX 155/165 (KX 170A/B,KX175A/B)..	2-31
2-13	PARTIAL INTCNT FOR DUAL KX 155/165 (KNS 81).....	2-33

BENDIX/KING**KX 155/165
VHF NAV/COMM TRANSCEIVER****SECTION II
INSTALLATION****2.1 GENERAL**

This section contains suggestions and factors to consider before installing the KX 155/165. Close adherence to these suggestions will assure a more satisfactory performance from the equipment.

2.2 UNPACKING AND INSPECTING EQUIPMENT

Exercise extreme care when unpacking the unit. Make a visual inspection of the unit for evidence of damage incurred during shipment. If a claim for a damage is to be made, save the shipping container to substantiate the claim. When all equipment is removed, place in the shipping container, all packing materials for use in unit storage or reshipment.

2.3 EQUIPMENT INSTALLATION

The KX 155/165 installation will conform to standards designated by the customer, installing agency and existing conditions as to the unit location and type of installation. However, the following suggestions should be considered before installing your KX 155/165. The installing agency will supply and fabricate all external cables. The connectors required are supplied by Bendix/King. Interconnect diagrams are Figures 2-5 through 2-13.

NOTE: Use good quality stranded wire with at least 600 volt insulation that will not support a flame.

If more than one Glideslope Receiver is to be operated from a single antenna, an antenna coupler such as the DORNE and MARGOLIN INC. (Model DMB 24-1) or equivalent should be used.

2.3.1 AVIONICS COOLING REQUIREMENTS FOR PANEL MOUNTED EQUIPMENT

The greatest single contributor to increased reliability of all modern day avionics is to limit the maximum operating temperature of the individual units. While modern day individual circuit designs consume much less electrical energy, the watts per cubic inch dissipated within avionics units remains much the same due to high density packaging techniques utilized. Consequently, the importance of providing avionics stack cooling is still with us.

BENDIX/KING**KX 155/165
VHF NAV/COMM TRANSCEIVER**

While each individual unit may not require forced air cooling, the combined heat load of several units operating in a typical avionics stack will significantly degrade the reliability of the avionics if provisions for stack cooling are not incorporated in the initial installation.

Recommendations on stack cooling are contained in Bendix/King Installation Bulletin #55. Failure to provide stack cooling will certainly lead to increased avionics maintenance costs and may void the Bendix/King warranty.

2.3.2 MOUNTING RACK INSTALLATION

- A. The KX 155/165 is mounted rigidly in the aircraft panel. Select a position in the panel that is not too close to any high external heat source. Remember to allow adequate space for installation of cables and connectors. Avoid sharp bends and placing the cables near aircraft control cables.
- B. Refer to Figure 2-3 for the KX 155/165 mounting dimensions. Mark and drill the mounting holes.
- C. Secure the mounting rack to the instrument panel per Figure 2-3. The rear mounting bosses should be attached to the aircraft by means of support brackets.

2.3.3 ANTENNA INSTALLATION

- A. Conventional 50 ohm horizontally polarized NAV Glideslope and vertically polarized COMM antennas are required with the KX 155/165. Vertically bent whip antennas are not recommended. Wideband COMM antennas provide efficient operation over the COMM band. Antennas should be installed per manufacturer's recommendations. Additional recommendations are as follows:
 1. COMM Antenna
 - a. Mount antenna on flat metal surface or install a ground plane at least 18 inches square.
 - b. The antenna should be well removed from any projections and the engine(s) and propeller.
 2. Navigation Antenna
 - a. The location should be well removed from other antennas, projections and engine(s). It should have a clear line of sight area if possible.
 - b. The antenna must be mounted symmetrically with the centerline of the aircraft.
 - c. Avoid running other coaxial and wires near the NAV antenna cable.

BENDIX/KINGKX 155/165
VHF NAV/COMM TRANSCEIVER

- B. The antenna connectors on the KX 155/165 are identified on the rear die casting.

NOTE: With KX 155/165 viewed from the front, the NAV antenna connector is on the right and the COMM antenna connector is on the left. This means that the NAV Frequency Selector and NAV Antenna are on the same side of the radio. The COMM Frequency Selector and COMM Antenna Connector are also on the same side of the radio. The Glideslope Antenna Connector is right above the NAV Antenna Connector.

2.3.4 CABLE HARNESS AND CONNECTOR ASSEMBLY

The KX 155/165 uses a special connector that mates directly with the printed circuit board inside the unit. Assembly of the connector is as follows:

- A. Contact Terminal Assembly using Molex Crimper (Figure 2-1)
1. Strip each wire 5/32" for contact terminal (Part Number 030-01107-XXXX). (The last two digits of the contact terminal part number indicates the number of terminals required).
 2. Open the Molex hand crimper HT 1921 with the engraved side toward the operator. Place the conductor tab section of a contact terminal on Anvil B with the contact portion facing away from the operator. Close the crimper slightly until the contact tabs touch the female jaw.
 3. Insert the stripped conductor until the insulation is even with the side of the crimper facing the operator. Crimp the conductor tabs by squeezing the handles together until the jaws are fully closed or a sufficient crimp is obtained.
 4. Move the lead to Anvil A. Place the insulating tab section on Anvil A. Crimp again until the jaws are fully closed or a sufficient crimp is obtained.
- B. Contact Insertion into Molex Connector Housing
1. After the contact terminals have been installed on the wiring harness, the contact terminals can be inserted into the proper location in the connector housing (P/N 030-01094-0054). The terminal cannot be inserted upside down. Be sure to push the terminal all the way in, until a click can be felt or heard.
 2. The self locking feature can be tested by gently pulling on the wire.

BENDIX/KING

KX 155/165
VHF NAV/COMM TRANSCEIVER

- C. Location of Polarizing Key in Housing
1. Prior to insertion of connector into rear of unit, check polarizing key position between contacts 3 and 4.
 2. Refer to Figure 2-4 to check correct position of polarizing key.
- D. Extraction of Contact from Molex Connector
1. Slip the flat narrow blade of a Molex contact ejector tool, HT-1884 (P/N 005-02012-0011), under the contact on the mating side of the connector. By turning the connector upside down one can see the blade slide into the stop.
 2. When the ejector is slid into place, the retaining tab of the contact is raised, allowing the contact to be removed by pulling moderately on the lead.
 3. Neither the contact or position is damaged by removing a contact; however, the contact should be checked visually before reinstalling in connector to be certain that retaining tab "A" extends as shown (see Figure 2-1).
- E. Coax Connector

Refer to Figure 2-2 for the details for mounting the right angle coaxial BNC connector to the coax cable. Install the connector into the mounting rack.

2.3.5 KX 155/165 INSTALLATION

CAUTION

SEE PARAGRAPH 2.3.1 FOR COOLING REQUIREMENTS.

- A. Looking at the top of the unit, make sure the front lobe of the holddown device is in a vertical position.
- B. Slide the unit into the mounting rack until the front lobe touches the mounting rack.
- C. Insert a 3/32" Allen wrench through the hole in the front panel to engage the locking screw. Turn clockwise until the rear lobe engages the mounting rack. Continue turning until the unit is secure in the mounting rack. Do not overtighten.
- D. For removal, turn the locking screw counterclockwise using a 3/32" Allen wrench until the unit disengages from the mounting rack. Pull the unit out of the mounting rack by pulling on the metal tabs located behind the front panel on each side of the unit.

BENDIX/KING**KX 155/165
VHF NAV/COMM TRANSCEIVER****2.4 POST INSTALLATION CHECK**

An operation performance flight test is recommended after the installation is completed to insure satisfactory performance of the equipment in its normal environment. Check all aircraft control movements to be sure no electrical cables interfere with their operation.

To check the communications transceiver, maintain an appropriate altitude and contact a ground station facility at a range of at least fifty nautical miles. Contact a ground station close in. Pull the volume control knob out to defeat the automatic squelch feature and listen for any unusual electrical noise which would reduce the COMM receiver sensitivity by increasing the squelch threshold. If possible, verify the communications capability on both the high and low end of the VHF COMM band.

CAUTION

AS AN ADDED PRECAUTION BEFORE THE FLIGHT, CHECK THE ANTENNA. VSWR SHOULD BE CHECKED WITH AN IN-LINE TYPE WATTMETER INSERTED IN THE COAXIAL TRANSMISSION LINE BETWEEN THE TRANSCEIVER AND THE ANTENNA. ANY PROBLEM WITH THE ANTENNA INSTALLATION WILL MOST LIKELY BE SEEN AS A HIGH REFLECTED POWER. A VSWR OF 3:1 WILL RESULT IN A 25% LOSS IN POWER.

NOTE: The brightness of the display can be set for the most pleasing intensity by adjusting R438 during low light level conditions. R438 is accessible through the top of the radio when it is partially pulled out of the rack.

To check the VOR/ILS system, select a VOR frequency within a forty nautical mile range. Listen to the VOR audio and insure that no electrical interference such as magneto noise is present. Check the tone identifier filter operation. Fly inbound or outbound on a selected VOR radial and check for proper LEFT-RIGHT and TO-FROM indications. Check the VOR accuracy.

NOTE: VOR Ground Station scalloping may be present.

BENDIX/KING

**KX 155/165
VHF NAV/COMM TRANSCEIVER**

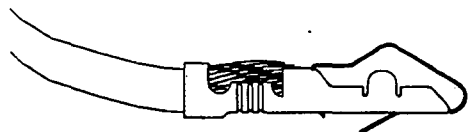
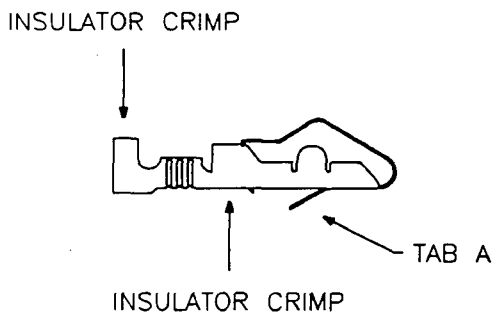

**SOLDERLESS CONTACT TERMINAL
P/N 030-01107-0030**

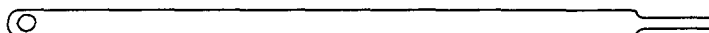

**HAND EJECTOR
P/N 047-05099-0001
MOLEX P/N HT-1884**

**FIGURE 2-1 MOLEX TERMINAL AND TOOLS
(Sheet 1 of 3)**

BENDIX/KING

**KX 155/165
VHF NAV/COMM TRANSCEIVER**

Holding the hand crimpers as shown, release the crimper's ratchet pawl and open by squeezing tightly on the handles, and then releasing pressure.

HAND CRIMPER
PN 071-06041-0000
MOLEX P/N 6115

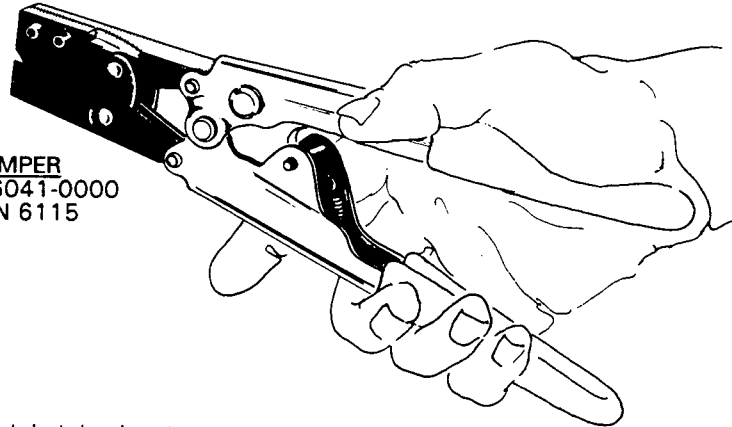

Close crimpers until ratchet begins to engage. Then insert the terminal into the jaws from the back side. (See Figures at bottom of page) For 24 to 30AWG wire, it will be necessary to start the crimp in jaw A and then complete it in jaw B.

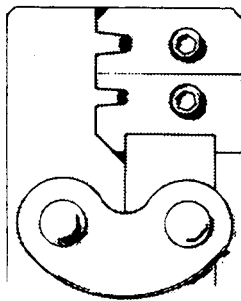

JAW	TERMINAL	WIRE SIZE	INSULATION RANGE
A	030-01107-0030	18 TO 24 AWG	.110 TO .055
B	030-01107-0030	24 TO 30 AWG	.055 TO .030

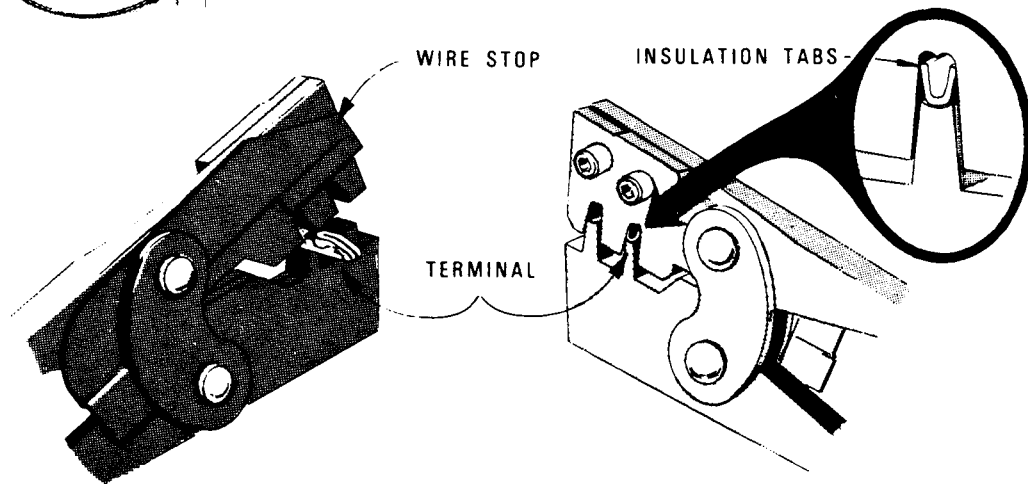

Terminal is in correct position when insulation tabs are flush with outside face of crimp jaws.

FIGURE 2-1 MOLEX TERMINAL AND TOOLS
(Sheet 2 of 3)

UP793797

BENDIX/KING

**KX 155/165
VHF NAV/COMM TRANSCEIVER**

Once the terminal is in the correct position, close the jaws gently until the terminal is held loosely in place. Push wire stop down so that it rests snugly behind the contact portion of the terminal.

Strip the wire insulation back 1/8 inch and insert the wire through the insulation tabs into the conductor tabs until the insulation hits the conductor jaw face or until the conductor touches the wire stop.

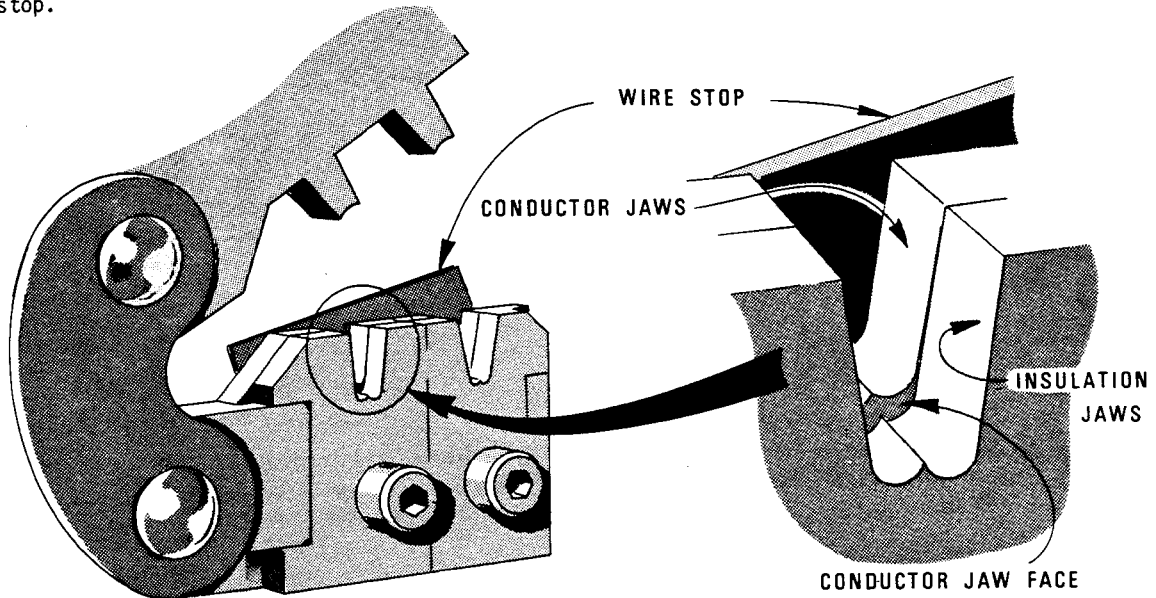

Squeeze the handles until the crimp jaws close and the ratchet releases.

Straighten the terminal if necessary, then release the plier grips and remove the crimped terminal.

CRIMPING PRESSURE ADJUSTMENT

If too much or too little pressure is needed to release the crimper's ratchet pawl at the end of the crimp stroke, the ratchet can be easily adjusted. A spanner wrench provided with the tool can be used to loosen the lock nut, and rotate the keyed stud clockwise for increased pressure and counter-clockwise for decreased pressure. Once the desired pressure has been set, the lock nut must be tightened again. Newer models may have a screwdriver adjustment.

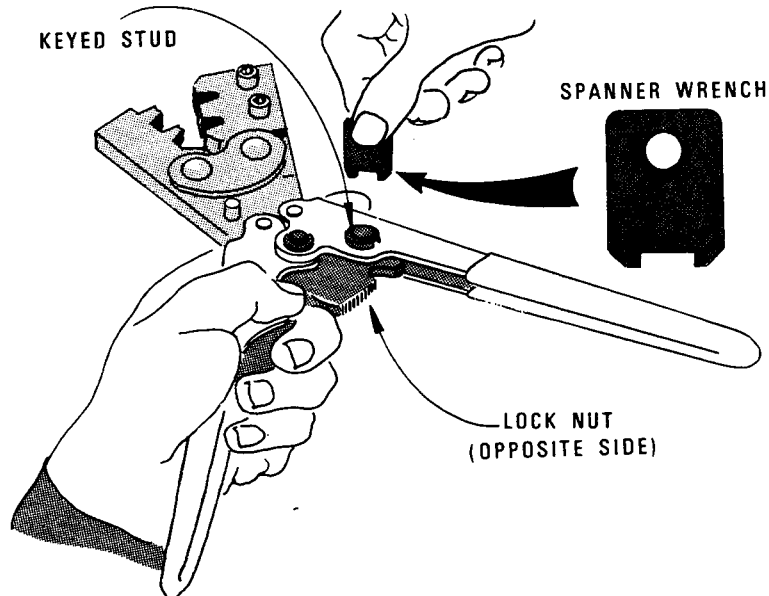

FIGURE 2-1 MOLEX TERMINAL AND TOOLS
(Sheet 3 of 3)

UP793797

BENDIX/KING

**KX 155/165
VHF NAV/COMM TRANSCEIVER**

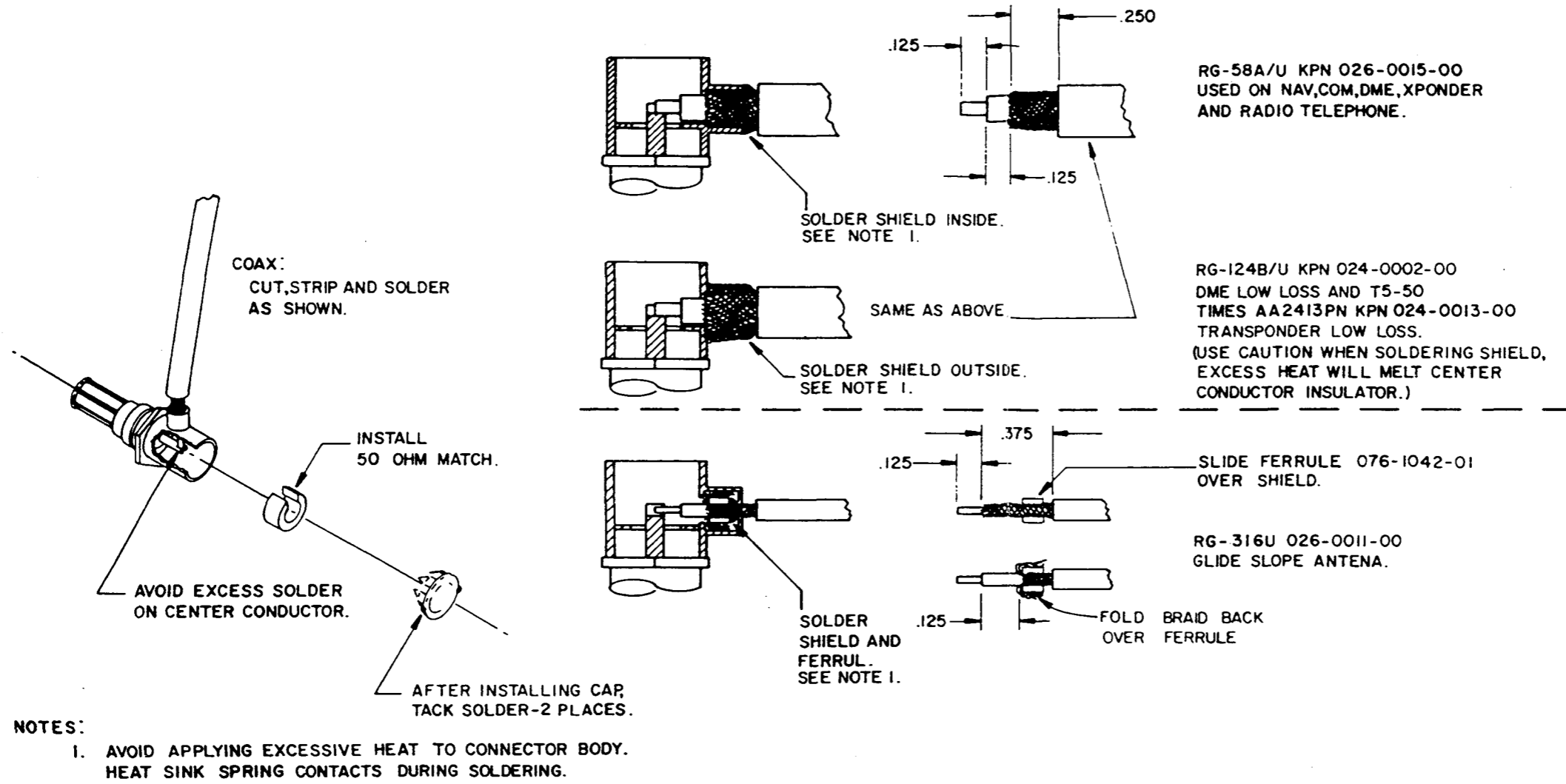
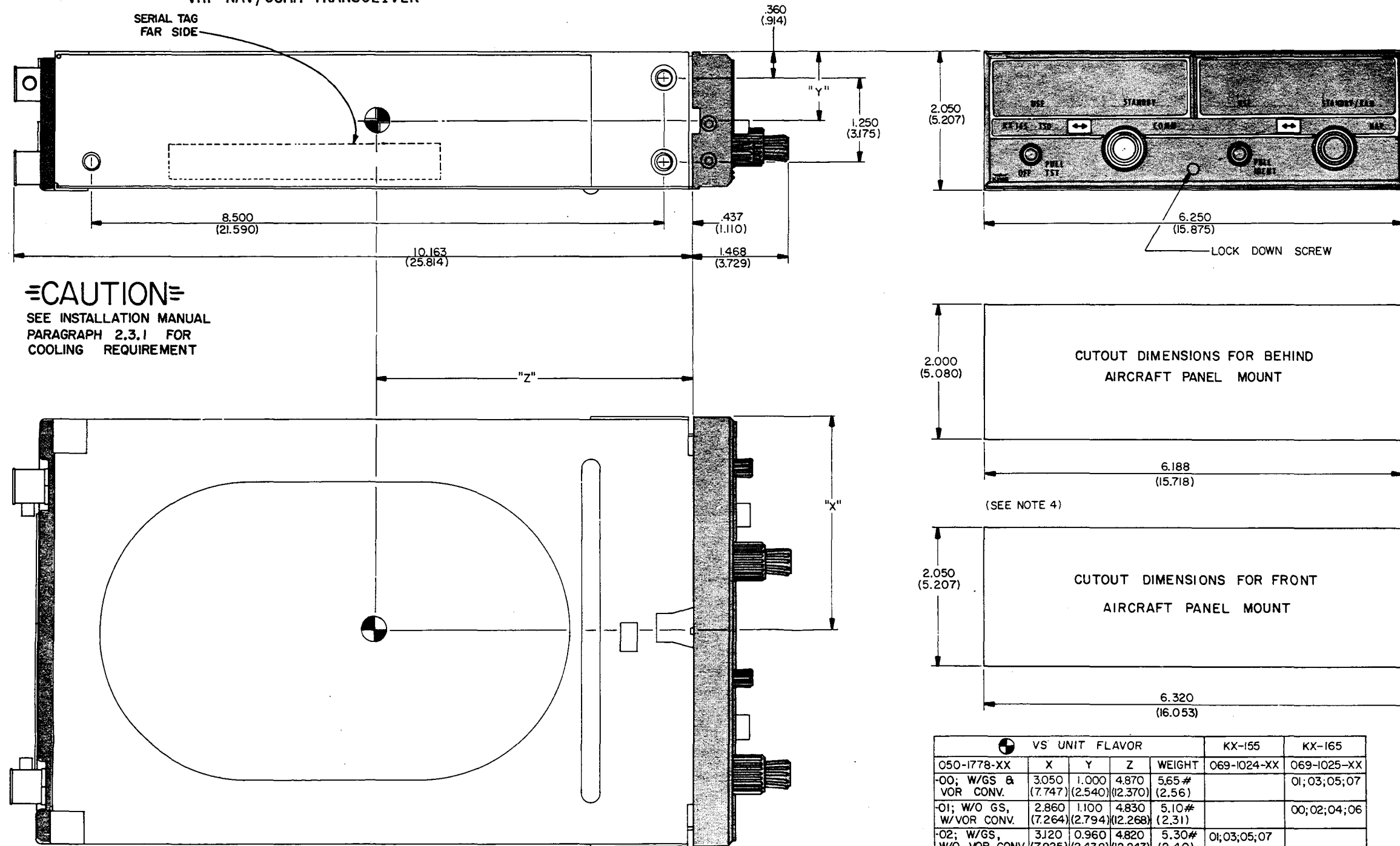

FIGURE 2-2 P/N 030-00101-0002 CONNECTOR ASSEMBLY

UP793797

BENDIX/KING

**KX 155/165
VHF NAV/COMM TRANSCEIVER**



CAUTION
SEE INSTALLATION MANUAL
PARAGRAPH 2.3.1 FOR
COOLING REQUIREMENT

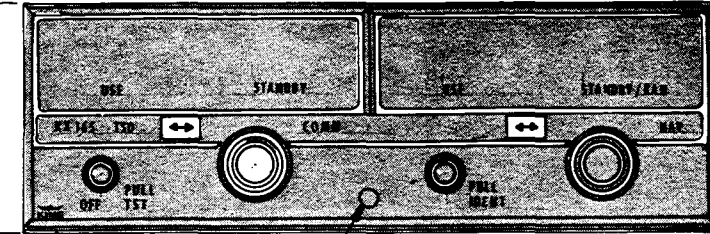

6.250 (15.875)
LOCK DOWN SCREW

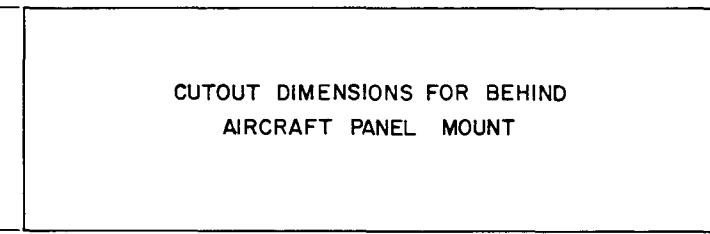

(SEE NOTE 4)

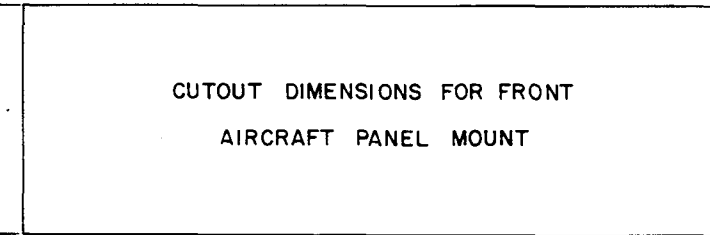

VS UNIT FLAVOR	X	Y	Z	WEIGHT	KX-155	KX-165
050-1778-XX					069-1024-XX	069-1025-XX
-00; W/GS & VOR CONV.	3.050 (7.747)	1.000 (2.540)	4.870 (12.370)	5.65# (2.56)		01; 03; 05; 07
-01; W/O GS, W/VOR CONV.	2.860 (7.264)	1.100 (2.794)	4.830 (12.268)	5.10# (2.31)		00; 02; 04; 06
-02; W/GS, W/O VOR CONV.	3.120 (7.925)	0.960 (2.438)	4.820 (12.243)	5.30# (2.40)	01; 03; 05; 07	
-03; W/O GS & VOR CONV.	2.950 (7.493)	1.190 (3.023)	4.750 (12.065)	4.75# (2.15)	00; 02; 04; 06	
-01 AUDIO	2.870 (7.290)	1.170 (2.972)	4.830 (12.243)	4.95# (2.24)	08; 09; 10; 11	
00 GS & AUDIO	3.040 (7.722)	0.940 (2.388)	4.900 (12.446)	5.50# (2.49)	12; 13; 14; 15	

- NOTES:
1. DIMENSIONS IN () ARE IN CENTIMETERS, KILOGRAMS.
 2. TOLERANCES FOR PANEL CUTOUTS: +.010 (+.025) - .000 (-.000)
 3. WHEN INSTALLING TWO OR MORE PANEL MOUNTED UNITS IN A STACK, THE MOUNTING TRAYS SHALL BE .050 INCHES (1.27cm) APART. NEWER STYLE MOUNTING TRAYS HAVE HAD .025 INCH (.635cm) DIMPLES BUILT IN, TOP AND BOTTOM, BOTH SIDES, SO THAT TWO NEW STYLE TRAYS WILL AUTOMATICALLY BE SPACED PROPERLY.
 4. TO DETERMINE STACK HEIGHT, USE THE HEIGHT DIMENSION FOR A FRONT AIRCRAFT PANEL MOUNT.

FIGURE 2-3 KX 155/165 OUTLINE AND MOUNTING DRAWING
(Dwg No 155-05319-0000, Rev 1)

UP793797

BENDIX/KING

**KX 155/165
VHF NAV/COMM TRANSCEIVER**

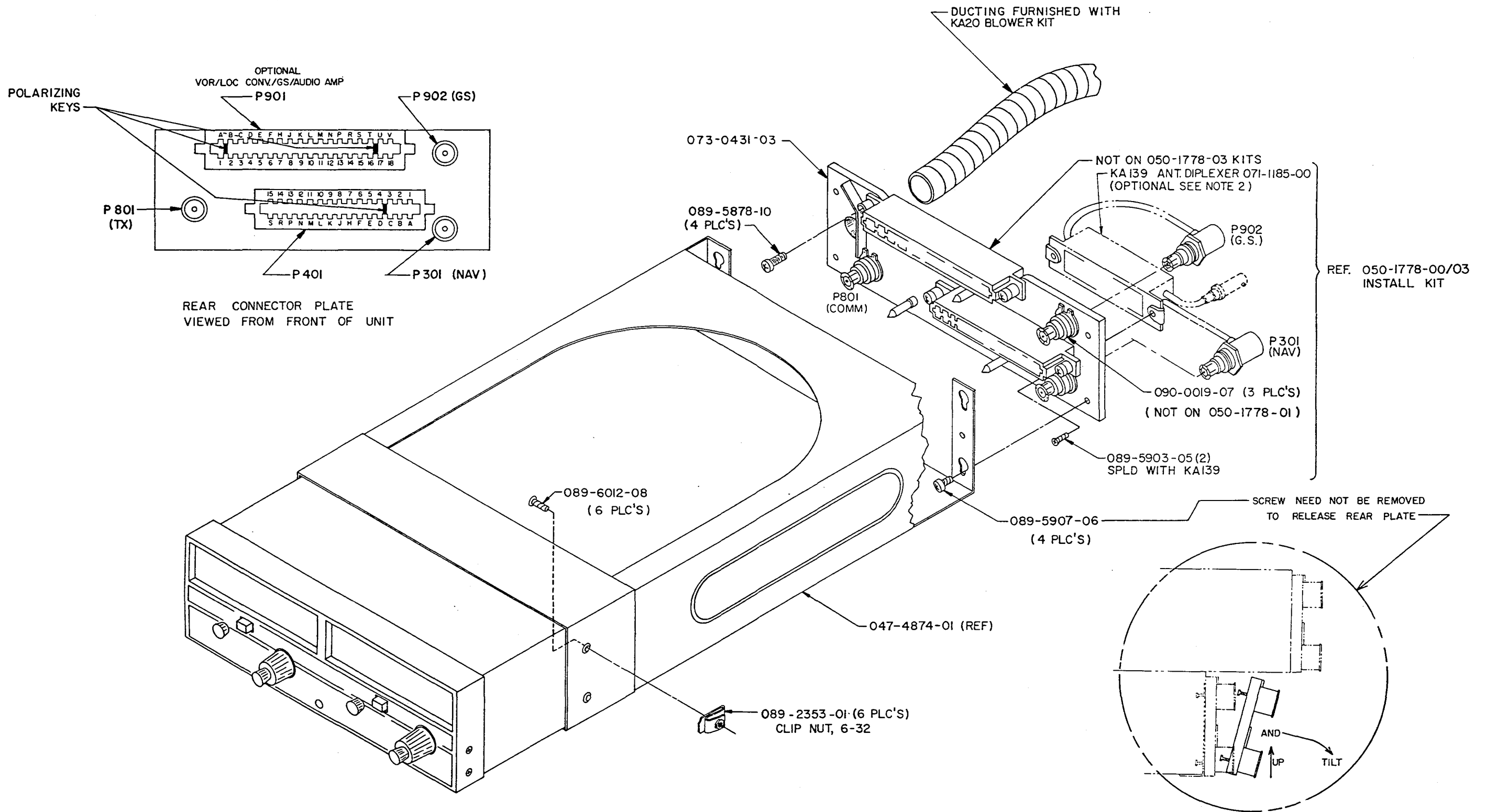
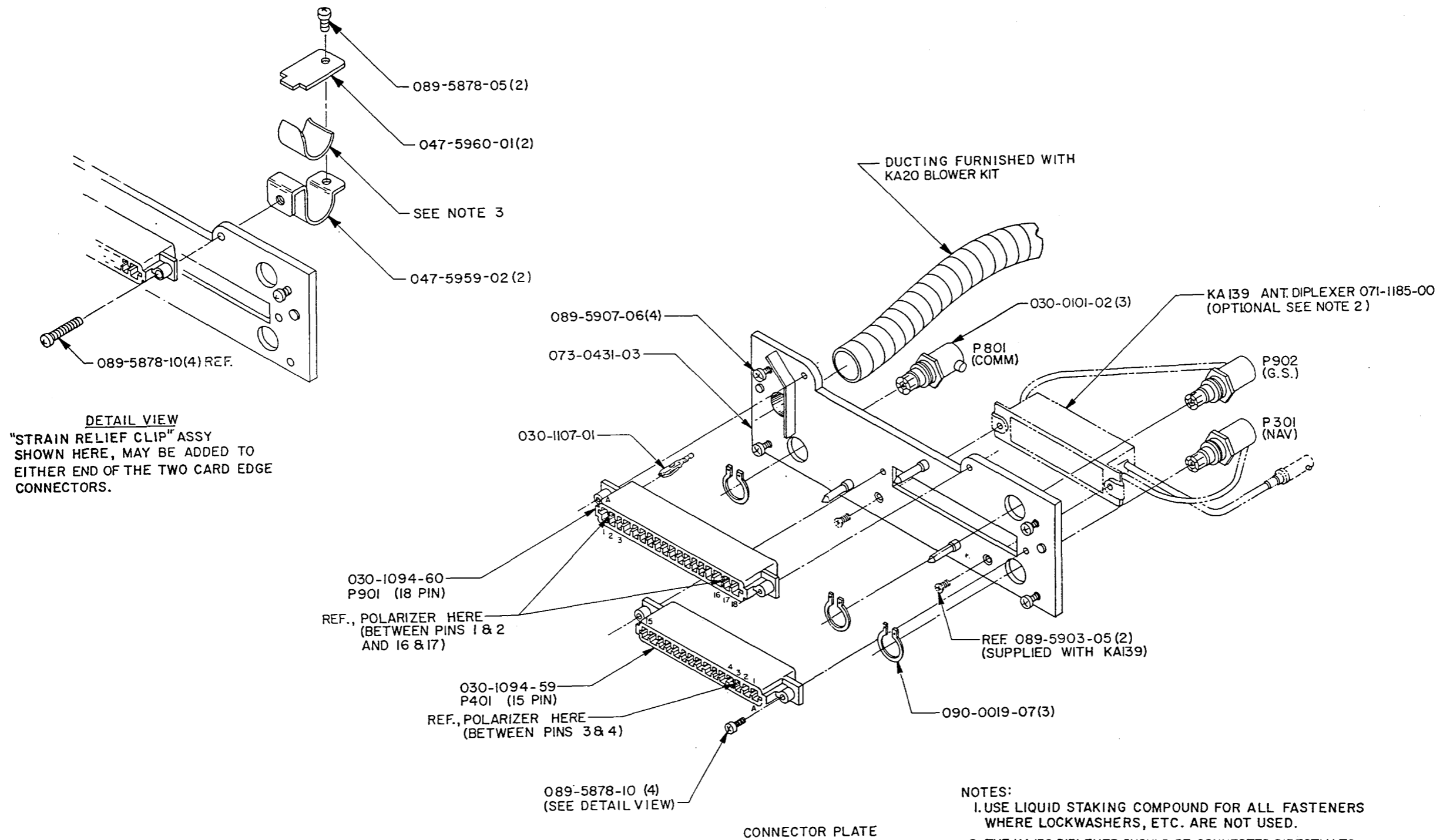

FIGURE 2-4 KX 155/165 INSTALLATION ASSEMBLY DRAWING
(Dwg No 300-02636-0000, Rev 8)
(Sheet 1 of 2)

UP793797

BENDIX/KING

**KX 155/165
VHF NAV/COMM TRANSCEIVER**



DETAIL VIEW
"STRAIN RELIEF CLIP" ASSY
SHOWN HERE, MAY BE ADDED TO
EITHER END OF THE TWO CARD EDGE
CONNECTORS.

- NOTES:**
1. USE LIQUID STAKING COMPOUND FOR ALL FASTENERS WHERE LOCKWASHERS, ETC. ARE NOT USED.
 2. THE KA I39 DIPLEXER SHOULD BE CONNECTED DIRECTLY TO THE NAV ANTENNA. DO NOT CONNECT THE KA I39 TO THE OUTPUT OF ANOTHER NAV SPLITTER. SOME NAV SPLITTERS WHICH ARE INTENDED TO DRIVE 2 VOR/LOC NAV RECEIVERS HAVE A SIGNIFICANT AMOUNT OF INSERTION LOSS WHEN USED TO DRIVE A GLIDESLOPE RECEIVER. IF A NAV ANTENNA IS USED IN COMMON WITH TWO VOR/LOC NAV RECEIVERS, THE KA I39 IS NOT RECOMMENDED.
 3. WRAP WIRE BUNDLE WITH ELECTRICAL FRICTION TAPE TO AVOID WIRE CHAFING.

FIGURE 2-4 KX 155/165 INSTALLATION ASSEMBLY DRAWING
(Dwg No 300-02636-0000, Rev 8)
(Sheet 2 of 2)

UP793797

BENDIX/KING

**KX 155/165
VHF NAV/COMM TRANSCEIVER**

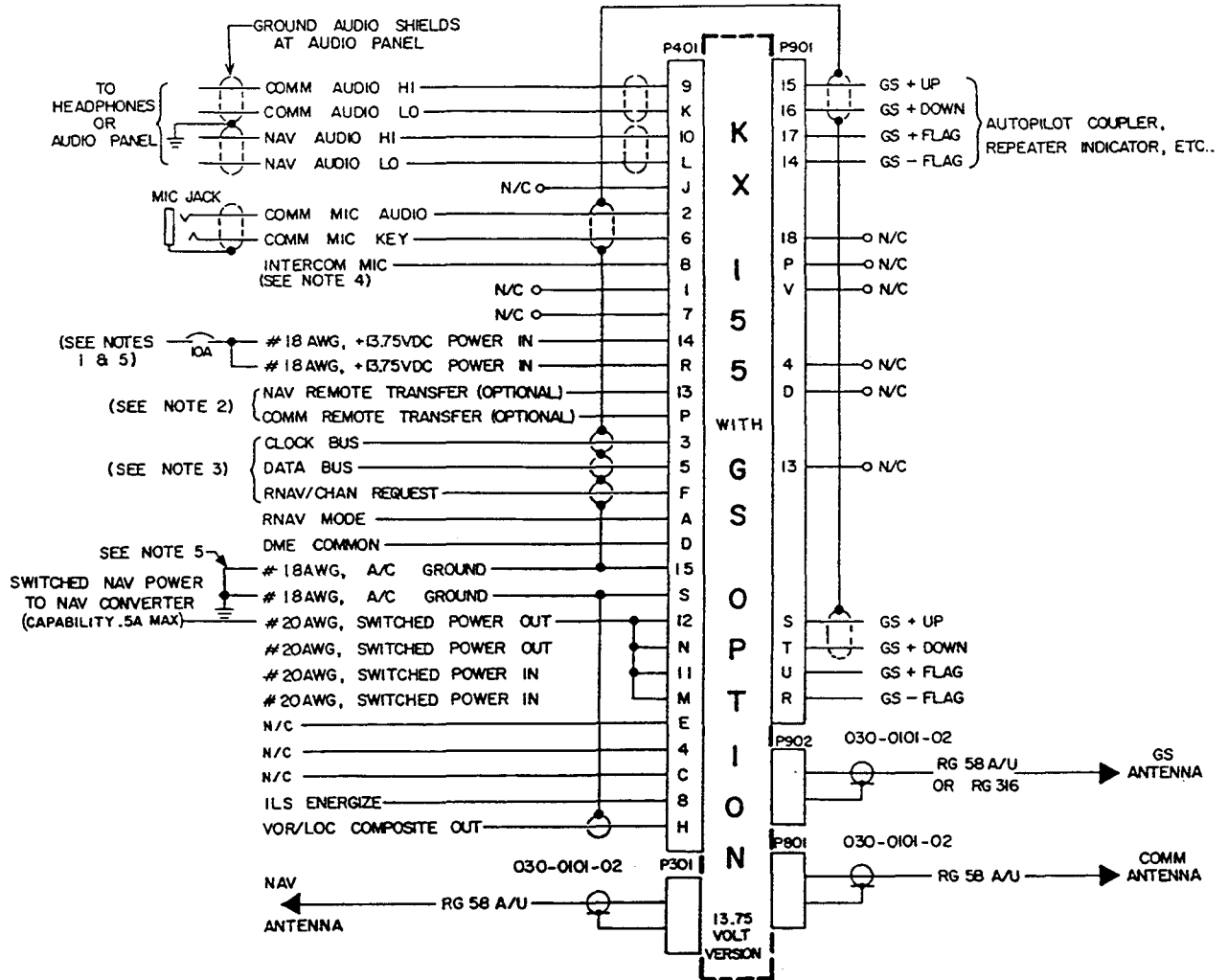

NOTES:

1. 27.5 VOLT OPERATION

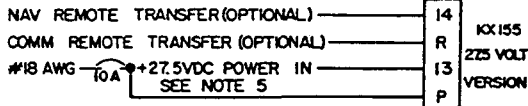

2. REMOTE TRANSFER ALLOWS TRANSFER OF "USE" AND "STBY" FREQUENCIES BY MEANS OF AN EXTERNAL SWITCH. 13.75 VOLT VERSIONS UTILIZE 27.5 VOLT POWER PINS FOR REMOTE TRANSFER INPUTS AND 27.5 VOLT VERSIONS UTILIZE THE 13.75 VOLT POWER PINS. IF REMOTE TRANSFER IS NOT DESIRED, THE INPUTS WILL NOT REQUIRE ANY CONNECTION. IF REMOTE TRANSFER IS DESIRED THE APPROPRIATE TRANSFER INPUT SHOULD BE MOMENTARILY SWITCHED FROM A/C GROUND TO A/C POWER.

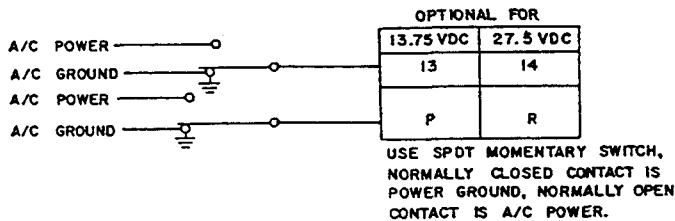

3. DME TUNING TO KN 62/62A/64, KDI 572/574, OR KPI 553A IS ACHIEVED SERIALLY. PARALLEL 2X5 OR SLIP CODE DME CHANNELING CAN BE ACHIEVED BY USE OF A KA 120 SERIAL TO PARALLEL CHANNEL ADAPTER. THE KA 120 MAY ALSO PROVIDE PARALLEL CHANNELING FOR OTHER KING GLIDESLOPE RECEIVERS.

4. INTERCOM WIRING OPTION:

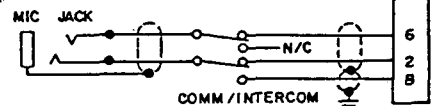

5. A/C POWER AND GND TO BE 2 - 18 AWG WIRES IN PARALLEL.

**FIGURE 2-5 KX 155 NAV/COMM TRANSCEIVER
(Dwg No 155-01343-0000, Rev 3)**

UP793797

BENDIX/KING

**KX 155/165
VHF NAV/COMM TRANSCEIVER**

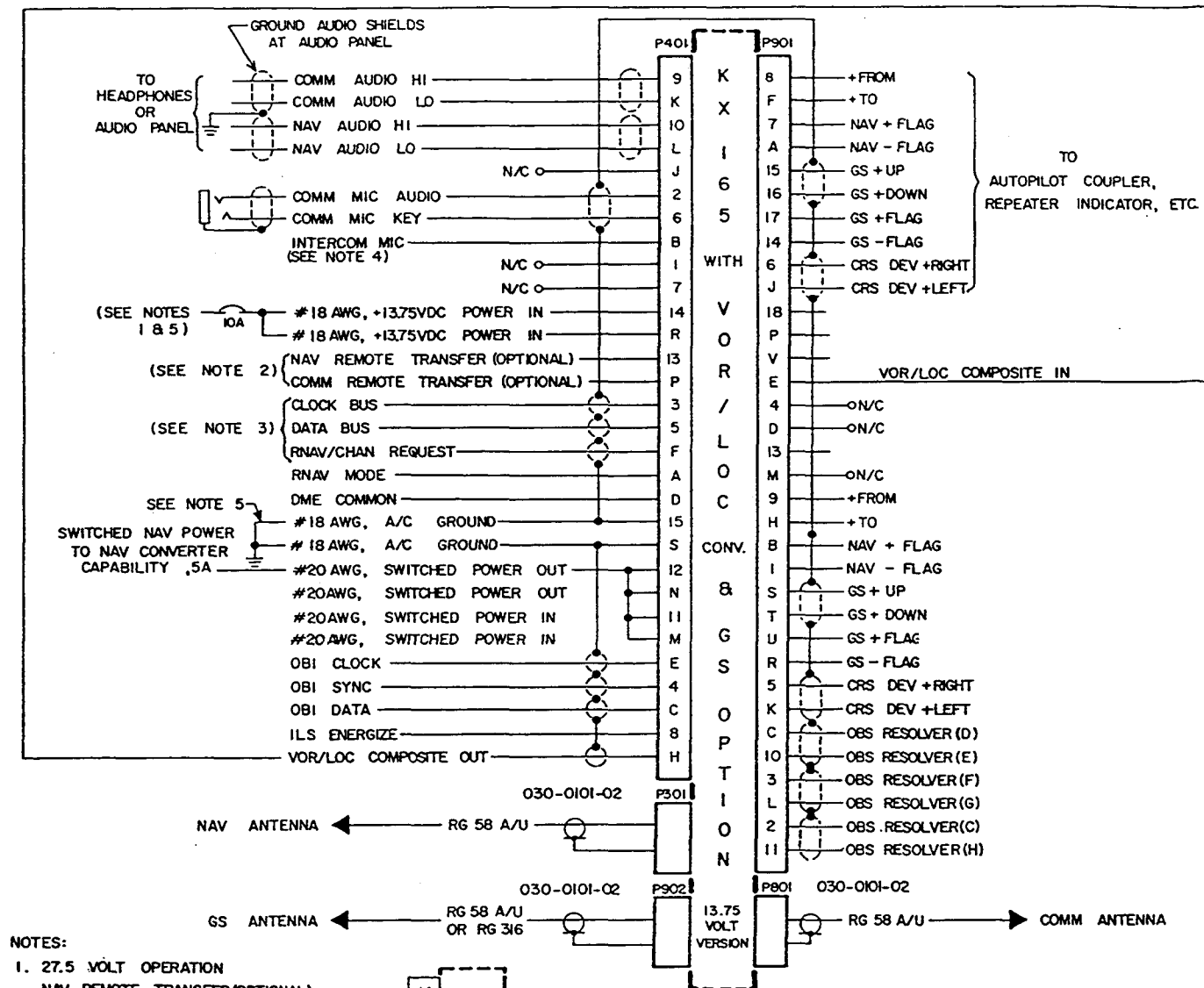

NOTES:

1. 27.5 VOLT OPERATION

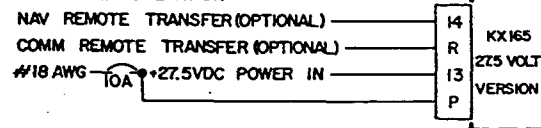

2. REMOTE TRANSFER ALLOWS TRANSFER OF "USE" AND "STBY" FREQUENCIES BY MEANS OF AN EXTERNAL SWITCH. 13.75 VOLT VERSIONS UTILIZE 27.5 VOLT POWER PINS FOR REMOTE TRANSFER INPUTS AND 27.5 VOLT VERSIONS UTILIZE THE 13.75 VOLT POWER PINS. IF REMOTE TRANSFER IS NOT DESIRED, THE INPUTS WILL NOT REQUIRE ANY CONNECTION. IF REMOTE TRANSFER IS DESIRED THE APPROPRIATE TRANSFER INPUT SHOULD BE MOMENTARILY SWITCHED FROM A/C GROUND TO A/C POWER.

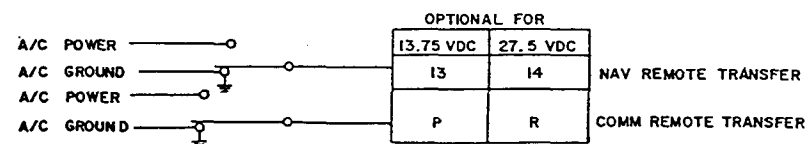

USE SPDT MOMENTARY SWITCH, NORMALLY CLOSED CONTACT IS POWER GROUND, NORMALLY OPEN CONTACT IS A/C POWER.

3. DME TUNING TO KN 62/62A/64, KDI 572/574, OR KPI 553A IS ACHIEVED SERIALLY. PARALLEL 2 X5 OR SLIP CODE DME CHANNELLING CAN BE ACHIEVED BY USE OF A KA 120 SERIAL TO PARALLEL CHANNEL ADAPTER. THE KA 120 MAY ALSO PROVIDE PARALLEL CHANNELLING FOR OTHER KING GLIDESLOPE RECEIVERS.

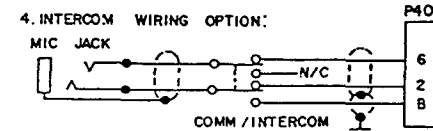

5. A/C POWER AND GND TO BE 2-18 AWG WIRES IN PARALLEL.

**FIGURE 2-6 KX 165 NAV/COMM VOR/LOC CONVERTER W/GS OPTION
(Dwg No 155-01345-0000, Rev 4)**

UP793797

BENDIX/KING
KX 155/165
VHF NAV/COMM TRANSCEIVER

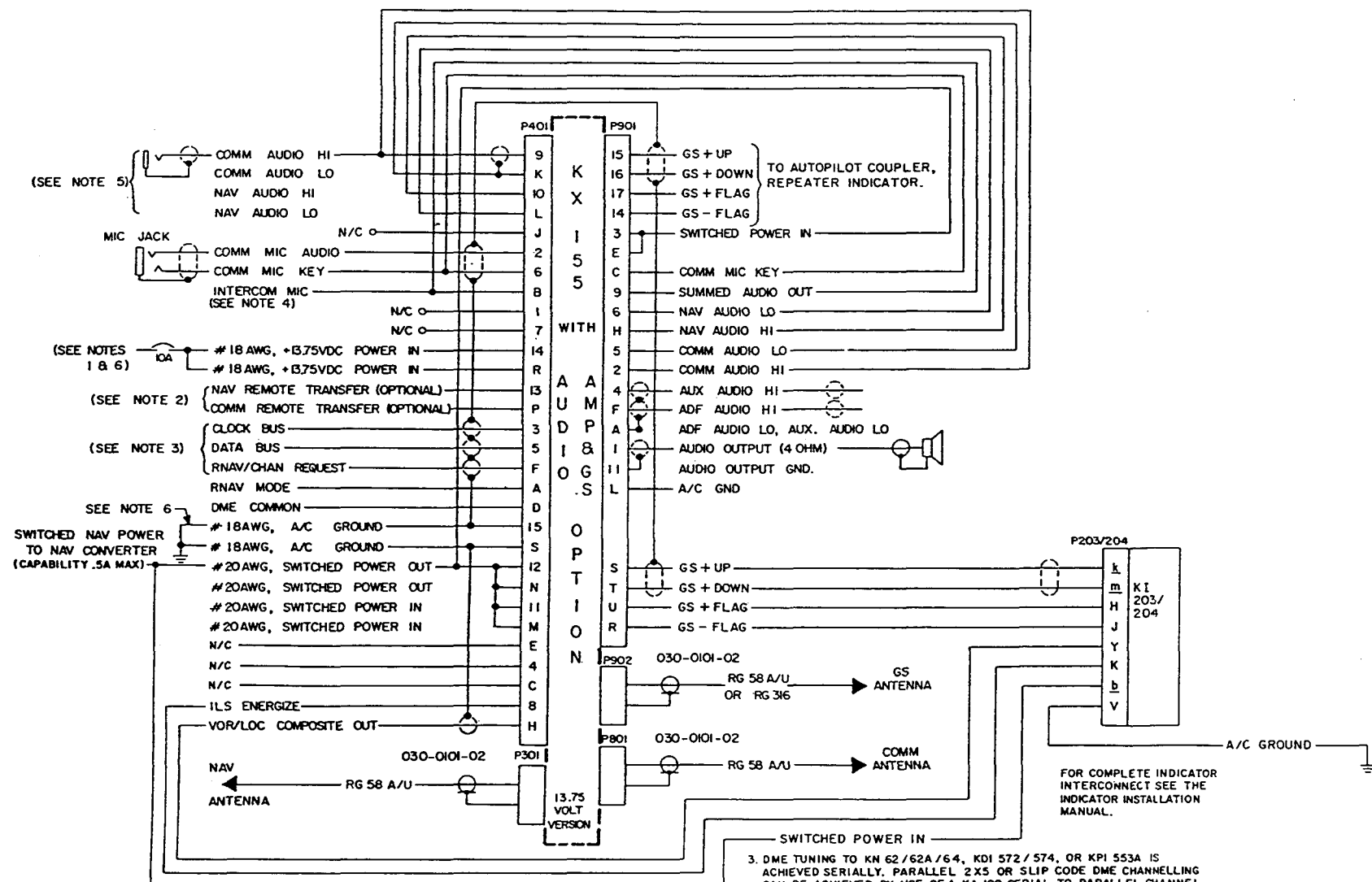

NOTES:

- 27.5 VOLT OPERATION
 NAV REMOTE TRANSFER (OPTIONAL) — 14 KX155
 COMM REMOTE TRANSFER (OPTIONAL) — R 27.5 VOLT
 #18 AWG 10A +27.5VDC POWER IN — 13 VERSION
 SEE NOTE 6
- REMOTE TRANSFER ALLOWS TRANSFER OF "USE" AND "STBY" FREQUENCIES BY MEANS OF AN EXTERNAL SWITCH. 13.75 VOLT VERSIONS UTILIZE 27.5 VOLT POWER PINS FOR REMOTE TRANSFER INPUTS AND 27.5 VOLT VERSIONS UTILIZE THE 13.75 VOLT POWER PINS. IF REMOTE TRANSFER IS NOT DESIRED, THE INPUTS WILL NOT REQUIRE ANY CONNECTION. IF REMOTE TRANSFER IS DESIRED THE APPROPRIATE TRANSFER INPUT SHOULD BE MOMENTARILY SWITCHED FROM A/C GROUND TO A/C POWER.
- DME TUNING TO KN 62/62A/64, KDI 572/574, OR KPI 553A IS ACHIEVED SERIALLY. PARALLEL 2 X 5 OR SLIP CODE DME CHANNELLING CAN BE ACHIEVED BY USE OF A KA 120 SERIAL TO PARALLEL CHANNEL ADAPTER. THE KA 120 MAY ALSO PROVIDE PARALLEL CHANNELLING FOR OTHER KING GLIDESLOPE RECEIVERS.
- INTERCOM WIRING OPTION:
 MIC JACK — 6
 COMM/INTERCOM — 2, B
- FOR ALL KX 155'S WITH AUDIO AMP OPTION, COMM AUDIO, PIN 9 P401, IS THE SUMMED AUDIO OUTPUT TO DRIVE THE A/C HEADPHONES, COMM AUDIO, PIN 9 P401 CONTAINS COMM, NAV, ADF, AUX., AND INTERCOM AUDIO INFORMATION WHEN WIRED PER THIS DRAWING.
- A/C POWER AND GND TO BE 2-18 AWG WIRES IN PARALLEL.

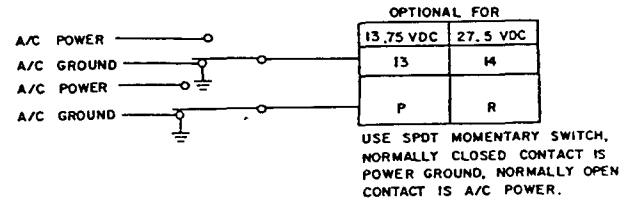
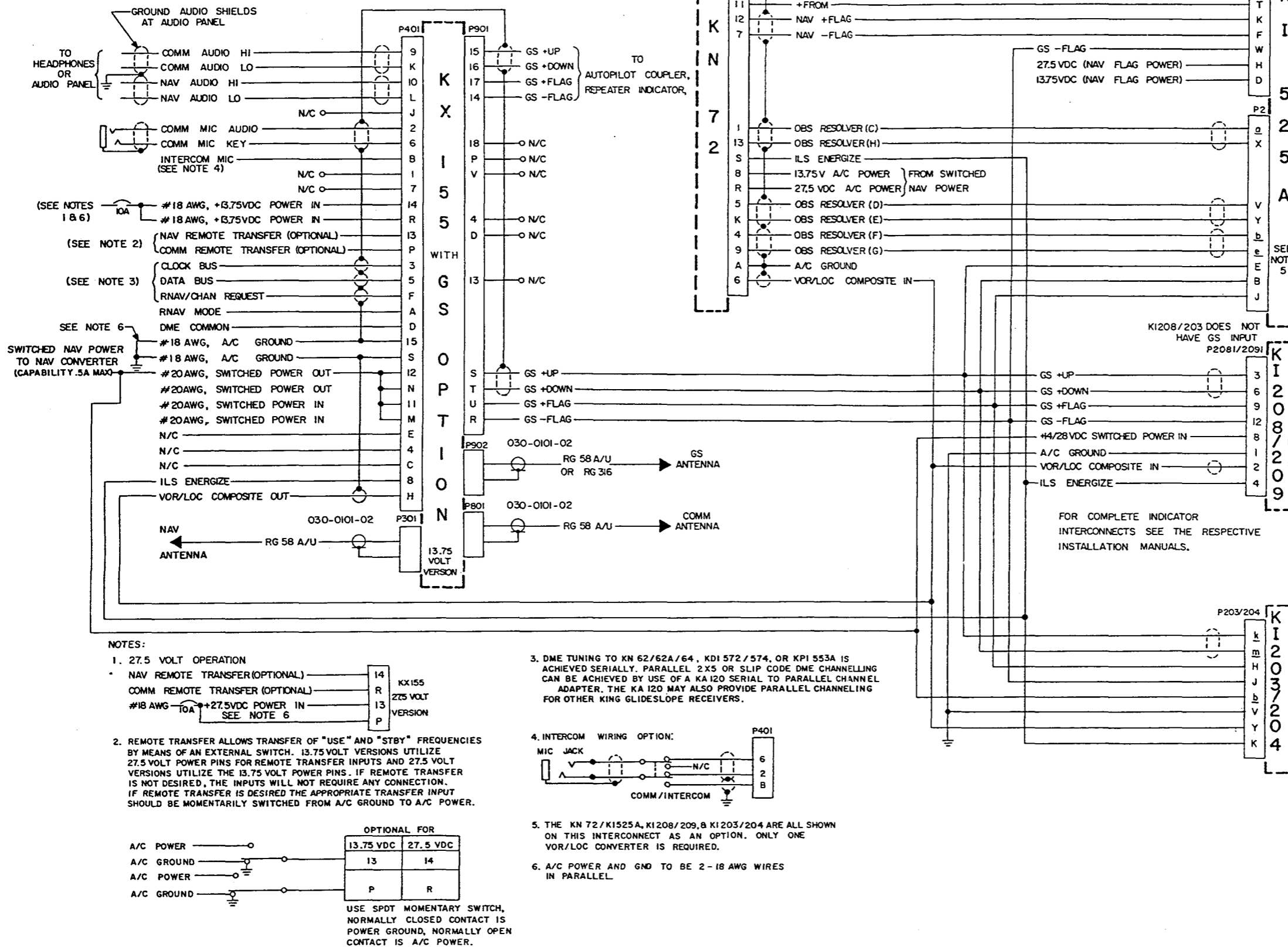

FIGURE 2-7 KX 155 NAV/COMM TRANSCEIVER WITH AUDIO AMP OPTION
 (Dwg No 155-01402-0000, Rev 5)

UP793797

BENDIX/KING

**KX 155/165
VHF NAV/COMM TRANSCEIVER**

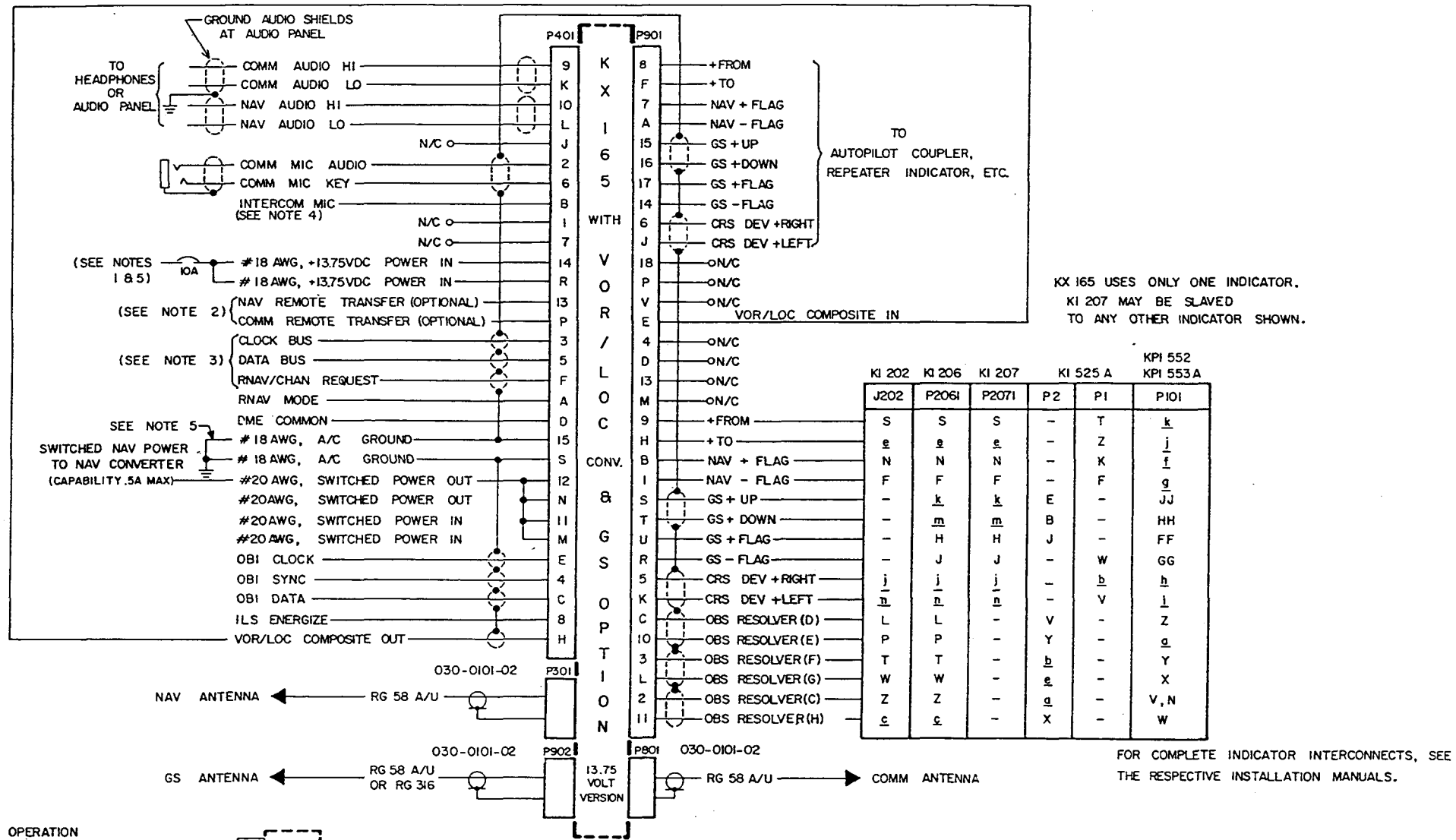

**FIGURE 2-8 KX 155 NAV/COMM TRANSCEIVER & GS OPTION
W/KN 72, KI 208, KI 209 & KI 525A
(Dwg No 155-01344-0000, Rev 5)**

UP793797

BENDIX/KING

**KX 155/165
VHF NAV/COMM TRANSCEIVER**



KX 165 USES ONLY ONE INDICATOR.
KI 207 MAY BE SLAVED
TO ANY OTHER INDICATOR SHOWN.

FOR COMPLETE INDICATOR INTERCONNECTS, SEE
THE RESPECTIVE INSTALLATION MANUALS.

NOTES:

1. 27.5 VOLT OPERATION

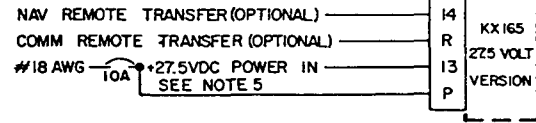

2. REMOTE TRANSFER ALLOWS TRANSFER OF "USE" AND "STBY" FREQUENCIES BY MEANS OF AN EXTERNAL SWITCH. 13.75 VOLT VERSIONS UTILIZE 27.5 VOLT POWER PINS FOR REMOTE TRANSFER INPUTS AND 27.5 VOLT VERSIONS UTILIZE THE 13.75 VOLT POWER PINS. IF REMOTE TRANSFER IS NOT DESIRED, THE INPUTS WILL NOT REQUIRE ANY CONNECTION. IF REMOTE TRANSFER IS DESIRED THE APPROPRIATE TRANSFER INPUT SHOULD BE MOMENTARILY SWITCHED FROM A/C GROUND TO A/C POWER.

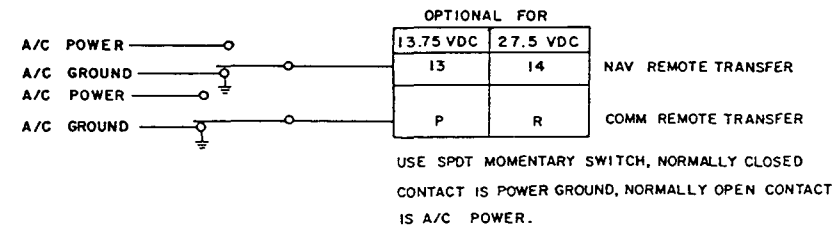

3. DME TUNING TO KN62/62A/64, KDI 572/574, OR KPI 553A IS ACHIEVED SERIALLY. PARALLEL 2X5 OR SLIP CODE DME CHANNELLING CAN BE ACHIEVED BY USE OF A KA120 SERIAL TO PARALLEL CHANNEL ADAPTER. THE KA 120 MAY ALSO PROVIDE PARALLEL CHANNELLING FOR OTHER KING GLIDESLOPE RECEIVERS.

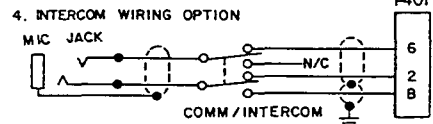

5. A/C POWER AND GND TO BE 2- 18AWG WIRES IN PARALLEL.

**FIGURE 2-9 KX 165 NAV/COMM VOR/LOC CONV & GS OPTION
W/KI 202, KI 206, KI 207, KI 525A, KI 552 & KPI 553A
(Dwg No 155-01346-0000, Rev 5)**

BENDIX/KING

**KX 155/165
VHF NAV/COMM TRANSCEIVER**

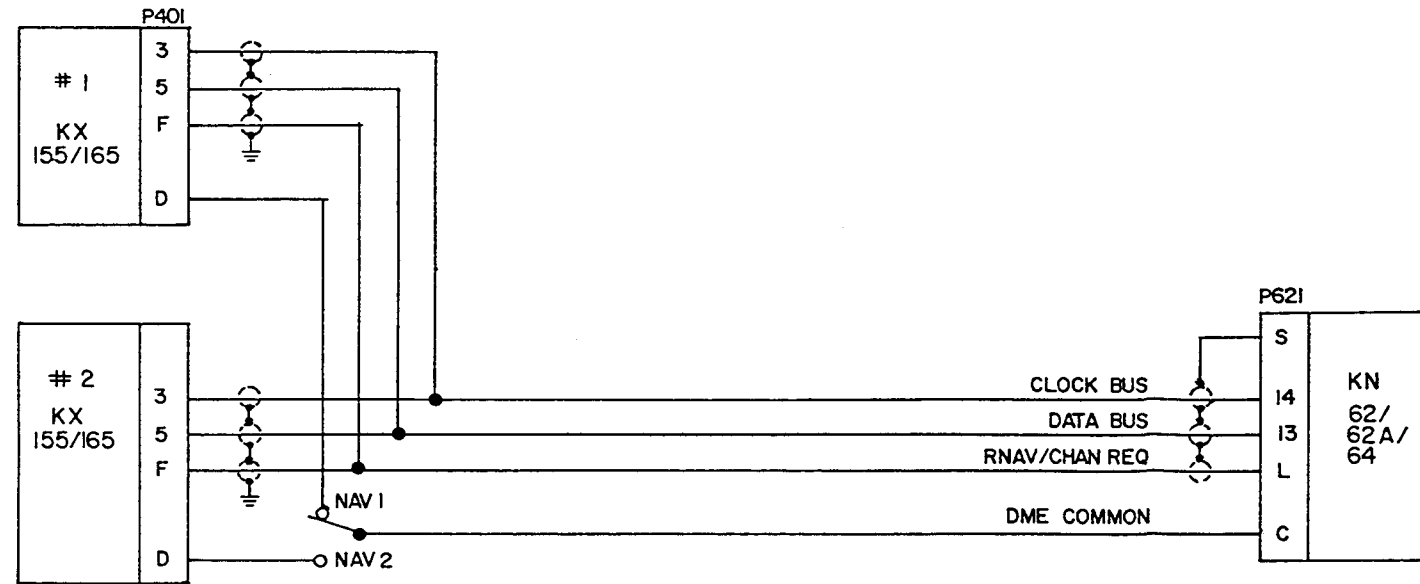

NOTE:

WHEN CHANNELING A KN62/62A/64 FROM TWO KX155/165'S, THE CLOCK BUS DATA BUS AND RNAV/CHAN REQ CAN BE PARALLELED. WITH ALL CODE SELECT LINES OPEN THE KN 62/62A CHANNELS SERIALY. THE SWITCHING IS PERFORMED BY SWITCHING THE DME COMMON, AS DONE WITH PARALLEL CHANNELING SOURCES. ONLY THE KX155/165 WITH THE DME COMMON PULLED LOW WILL RESPOND ON THE DATA BUS TO A CHANNEL REQUEST.

FIGURE 2-10 PARTIAL INTRCNT FOR DUAL KX 155/165 CHANNELING KN 62/62A/64
(Dwg No 155-05732-0000, Rev 0)

BENDIX/KING

KX 155/165
VHF NAV/COMM TRANSCEIVER

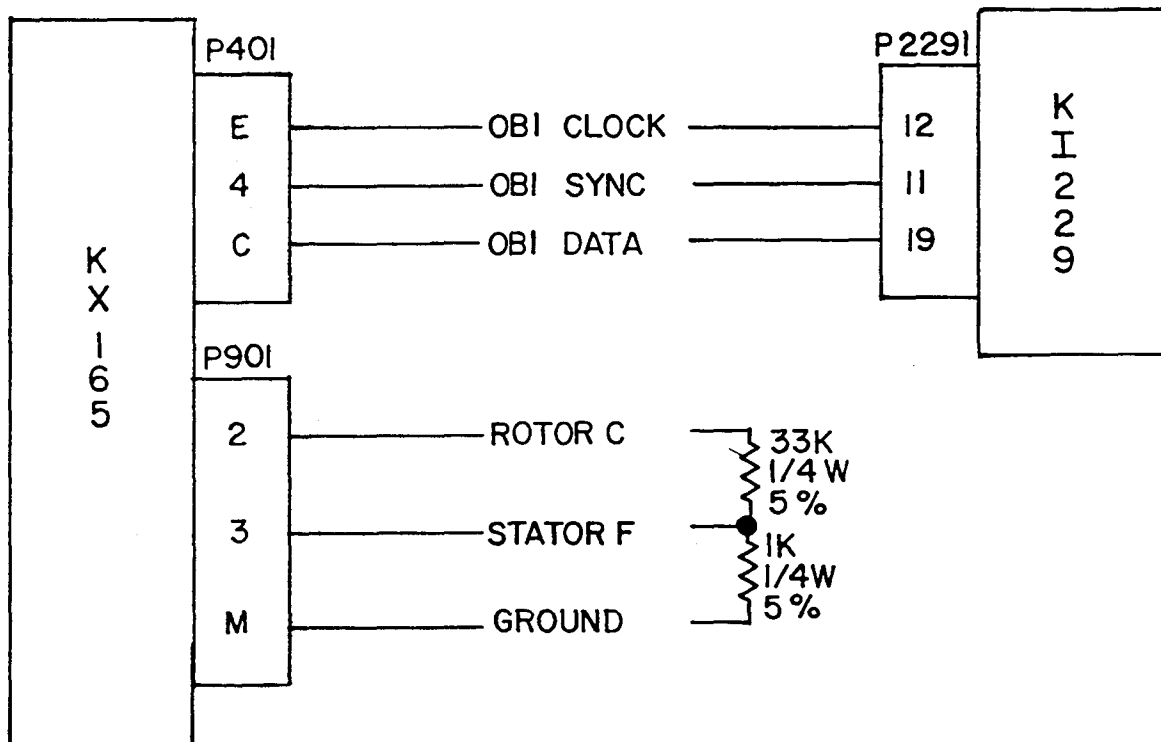
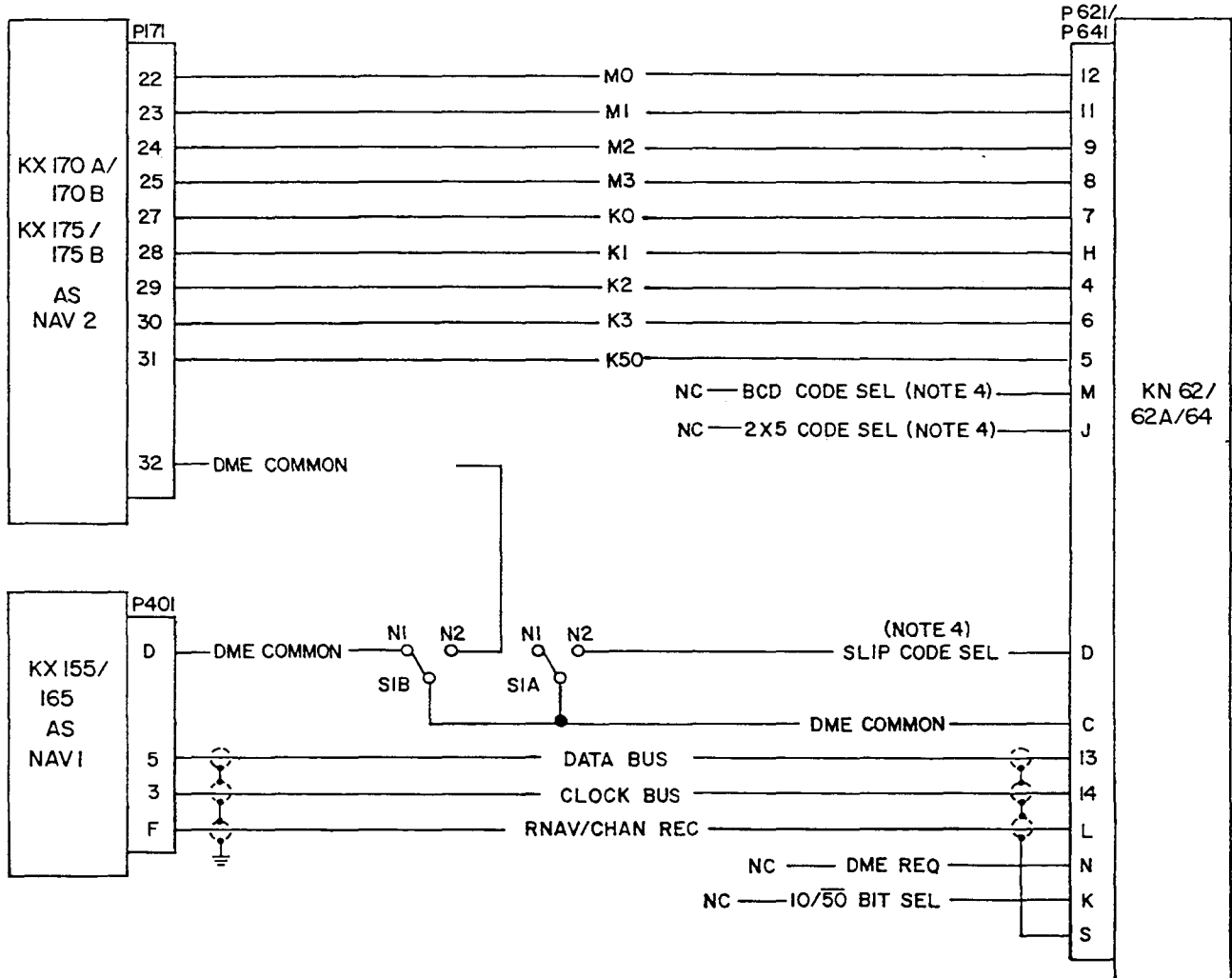

FIGURE 2-11 PARTIAL INTERCONNECT FOR KX 155/165 AND KI 229
WITHOUT OBS RESOLVER
(Dwg No 155-05733-0000, Rev 0)

BENDIX/KING

**KX 155/165
VHF NAV/COMM TRANSCEIVER**



NOTES:

1. FOR COMPLETE LISTING OF ALL PIN FUNCTIONS REFER TO UNIT INSTALLATION MANUALS.
2. SI PROVIDES REMOTE NAV 1 / NAV 2 DME CHANNELING. WHEN TWO SERIAL SOURCES ARE USED THE DME COMMONS MAY BE SWITCHED BY A SPDT SWITCH. WHEN A SERIAL AND A PARALLEL SOURCE ARE USED A DPDT SWITCH IS NECESSARY SO THE CODE SELECT CAN ALSO BE SWITCHED.
3. WHEN USING A KN 62/62A/64 DME THE HOLD FUNCTION IS ACCOMPLISHED BY USE OF THE "FREQ" MODE OF THE DME.
4. CODE SELECT SHOWN IS FOR SLIP CODE CHANNELING. FOR BCD OR 2X5 CODE CHANNELING CONNECT TO THE APPROPRIATE PIN ON KN 62/62A/64 AND LEAVE THE OTHER TWO CODE SELECT LINES OPEN.

FIGURE 2-12 PARTIAL INTERCONNECT FOR KX 155/165 AND KX 170A/KX 170B/KX 170/175B CHANNELING KN 62/62A/64 (Dwg No 155-05734-0000, Rev 0)

BENDIX/KING

**KX 155/165
VHF NAV/COMM TRANSCEIVER**

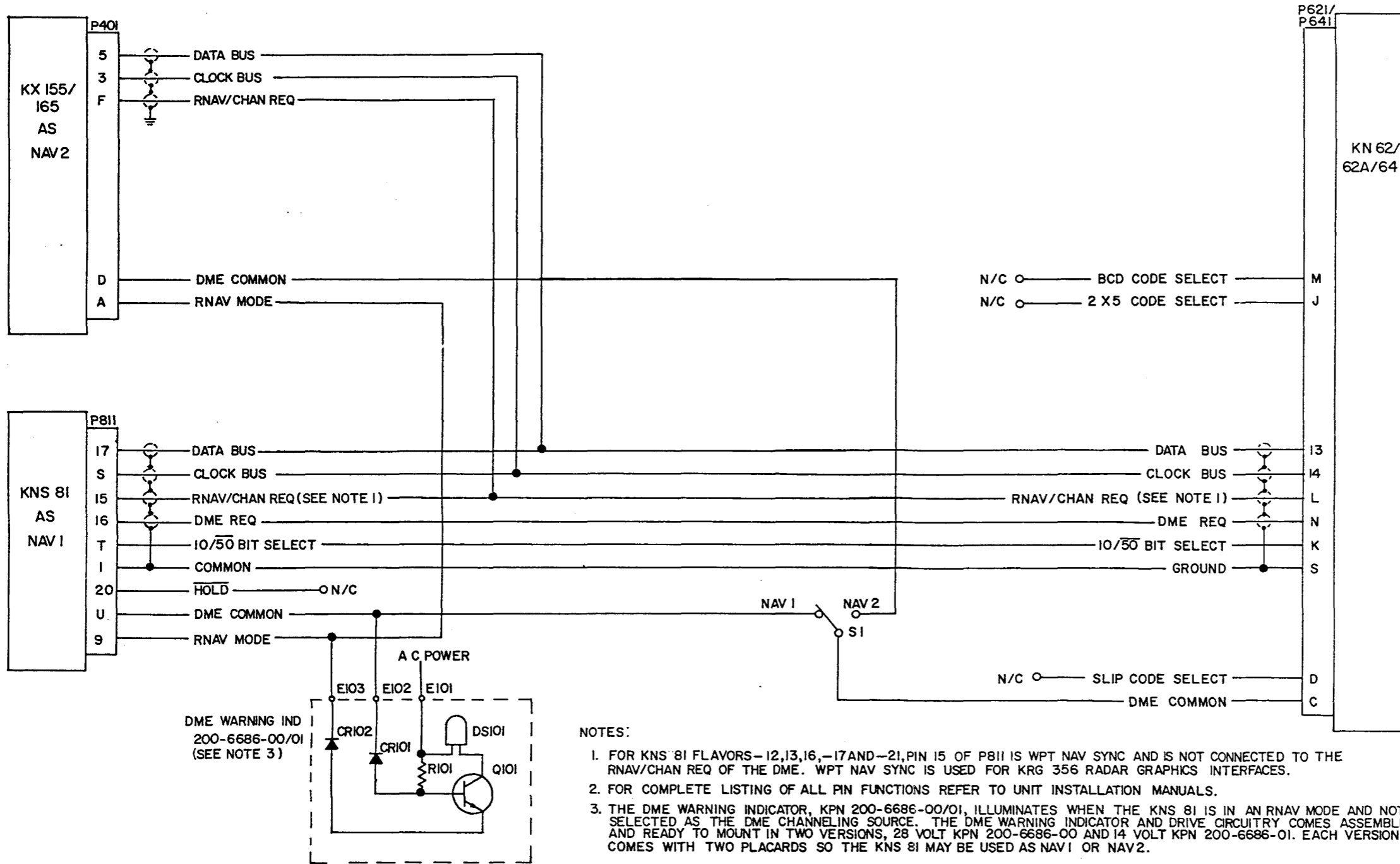

NOTES:

1. FOR KNS 81 FLAVORS -12,13,16,-17 AND -21, PIN 15 OF P811 IS WPT NAV SYNC AND IS NOT CONNECTED TO THE RNAV/CHAN REQ OF THE DME. WPT NAV SYNC IS USED FOR KRG 356 RADAR GRAPHICS INTERFACES.
2. FOR COMPLETE LISTING OF ALL PIN FUNCTIONS REFER TO UNIT INSTALLATION MANUALS.
3. THE DME WARNING INDICATOR, KPN 200-6686-00/01, ILLUMINATES WHEN THE KNS 81 IS IN AN RNAV MODE AND NOT SELECTED AS THE DME CHANNELING SOURCE. THE DME WARNING INDICATOR AND DRIVE CIRCUITRY COMES ASSEMBLED AND READY TO MOUNT IN TWO VERSIONS, 28 VOLT KPN 200-6686-00 AND 14 VOLT KPN 200-6686-01. EACH VERSION COMES WITH TWO PLACARDS SO THE KNS 81 MAY BE USED AS NAV 1 OR NAV 2.
4. S1 PROVIDES REMOTE NAV 1/ NAV 2 DME CHANNELING. WHEN TWO SERIAL SOURCES ARE USED THE DME COMMONS MAY BE SWITCHED BY A SPDT SWITCH. WHEN A SERIAL AND A PARALLEL SOURCE ARE USED A DPDT SWITCH IS NECESSARY SO THE CODE SELECT CAN ALSO BE SWITCHED.
5. WHEN USING A KN 62/62A/64 DME THE HOLD FUNCTIONS IS ACCOMPLISHED BY USE OF THE "FREQ" MODE OF THE DME.

**FIGURE 2-13 PARTIAL INTERCONNECT FOR KX 155/165
AND KNS 81 CHANNELING KN 62/62A/64
(Dwg No 155-05735-0000, Rev 0)**

UP793797

BENDIX/KING

**KX 155/165
VHF NAV/COMM TRANSCEIVER**

**SECTION III
OPERATION**

3.1	GENERAL	3-1
3.1.1	COMM TRANSCEIVER	3-1
3.1.2	NAV RECEIVER	3-2
3.2	INDICATOR CONTROLS AND FUNCTIONS	3-4
3.2.1	VOR OPERATION	3-4
3.2.2	LOC OPERATION	3-4
3.2.3	GLIDESLOPE OPERATION	3-4
3.2.4	UNIT CONTROL FUNCTIONS	3-4
3.3	KI 525A INDICATOR CONTROLS AND FUNCTIONS	3-6
3.3.1	VOR/LOC AND GLIDESLOPE OPERATION	3-6
3.4	KNI 229 RMI OPERATION	3-7
3.5	KPI 552 PICTORIAL NAVIGATION INDICATOR	3-7
3.6	KPI 553A PICTORIAL NAVIGATION INDICATOR	3-9
3.6.1	KPI 553A (Figure 3-6)	3-10

LIST OF ILLUSTRATIONS

FIGURE		PAGE
3-1	KX 155/165 CONTROL FUNCTION	3-3
3-2	TYPICAL INDICATOR MARKINGS	3-5
3-3	KI 525A INDICATOR AND CONTROLS	3-6
3-4	KNI 229 RADIO MAGNETIC INDICATOR	3-7
3-5	KPI 552 PICTORIAL NAVIGATION INDICATOR	3-8
3-6	KPI 553A PICTORIAL NAVIGATION INDICATOR	3-11

BENDIX/KING**KX 155/165
VHF NAV/COMM TRANSCEIVER****SECTION III
OPERATION****3.1 GENERAL**

All controls required to operate the KX 155/165 are located on the unit front panel. (See Figure 3-1)

3.1.1 COMM TRANSCEIVER

Rotate the VOL knob clockwise from the OFF position. Pull the VOL knob out and adjust for desired listening level. Push the VOL knob back in to actuate the automatic squelch.

The left portion of the digital display readout is allocated for COMM, USE, and STANDBY frequencies with a T between them to indicate the TRANSMIT mode of operation.

Select the desired operating frequency in the standby display by rotating the increment/decrement knobs either clockwise or counter-clockwise. A clockwise rotation will increment the previous frequency while a counterclockwise rotation will decrement the previous frequency.

The larger knob will change the MHz portion of the standby display. At one band-edge (118 or 135/136 MHz) the following 1 MHz change will wrap around to the other band-edge. The smaller knob will change the kHz portion of the standby display. It will change in steps of 50 kHz when the knob is pushed in, and 25 kHz when the knob is pulled out. The wrap around band-edge is also utilized when incrementing or decrementing the kHz portion of the standby display.

To tune the radio to the desired operating frequency, the desired frequency must be entered into the standby display and then the transfer button must be pushed. This will trade the contents of the active and standby display.

The transceiver is always tuned to the frequency appearing in the USE display. It is therefore possible to have two different frequencies stored in the USE and STANDBY displays and to change back and forth between them at the simple push of the transfer button.

During the transmit mode of operation, a T will appear between the USE and STANDBY displays, signifying that the transceiver is in the transmit mode of operation.

A non-volatile memory stores the comm USE and STANDBY frequencies on power down. When the unit is turned on again, the COMM USE and STANDBY windows will display the same USE and STANDBY frequencies that were displayed before power down. If an invalid frequency is detected in the memory, on power up the COMM USE and STANDBY windows will contain 120.00, thus indicating the presence of an error in the stored frequency.

BENDIX/KING**KX 155/165
VHF NAV/COMM TRANSCEIVER****3.1.2 NAV RECEIVER**

The right portion of the display is allocated to NAV receiver USE and STANDBY/RAD information. The frequency channeling is the same as the COMM when operating in the frequency mode. The NAV increment/decrement knob is located on the right hand side of the front panel. The larger knob operates in 1 MHz steps and increments/decrements the STANDBY/RAD frequency display.

The smaller knob operates in 50 kHz steps. The NAV receiver's lower and upper frequency limits are 108.00 MHz and 117.95 MHz. Exceeding the upper limit of frequency band would automatically return to the lower limit and vice versa. When the smaller knob is pulled out, the VOR bearing is digitally displayed in STANDBY/RAD window.

In the bearing mode, the increment/decrement knob channels the USE frequency window and depressing the frequency transfer button will cause the USE frequency to be placed in blind storage and the STANDBY frequency (in the blind storage) to be displayed in the USE window display.

In radial mode (KX 165 only) of operation, the right hand window of NAV display shows the bearing FROM the station and when due to weak signals the warning flag is activated, a digital flag, ---, will be displayed in the radial window. Also, when an ILS frequency is selected, the digital flag --- is displayed in the radial window.

The NAV USE and STANDBY frequencies are stored in the memory on power down and return on power up. On power up, if an error is detected in the stored frequencies, the unit will display 110.00 MHz in both USE and STANDBY/RAD windows. The unit does not store the VOR bearing on power down.

When the smaller increment/decrement knob is pushed in, depressing the NAV TRANSFER button will interchange the USE and STANDBY/RAD frequencies. The NAV IDENT knob is active in the pulled out position so that both voice and ident can be heard. When this knob is pushed in, the ident tone is attenuated. The volume of voice/ident can be adjusted by turning this knob.

BENDIX/KING

KX 155/165
VHF NAV/COMM TRANSCEIVER

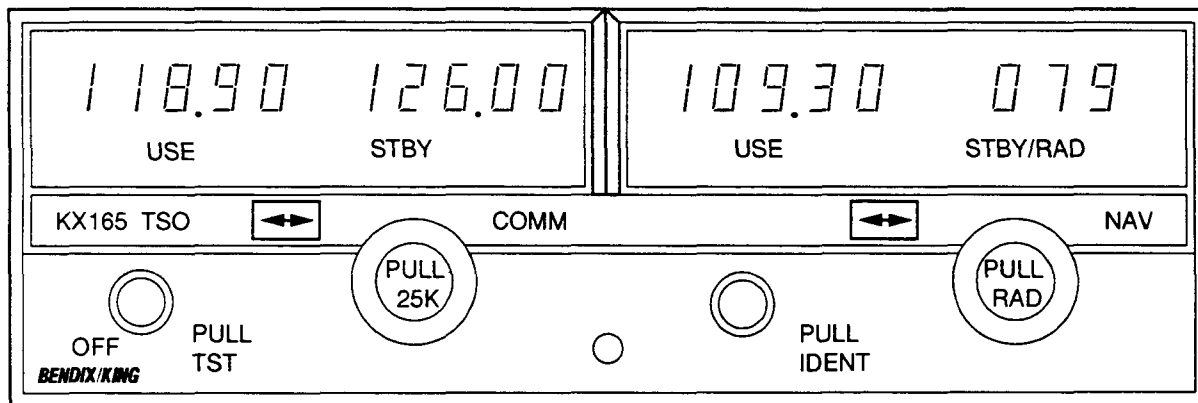
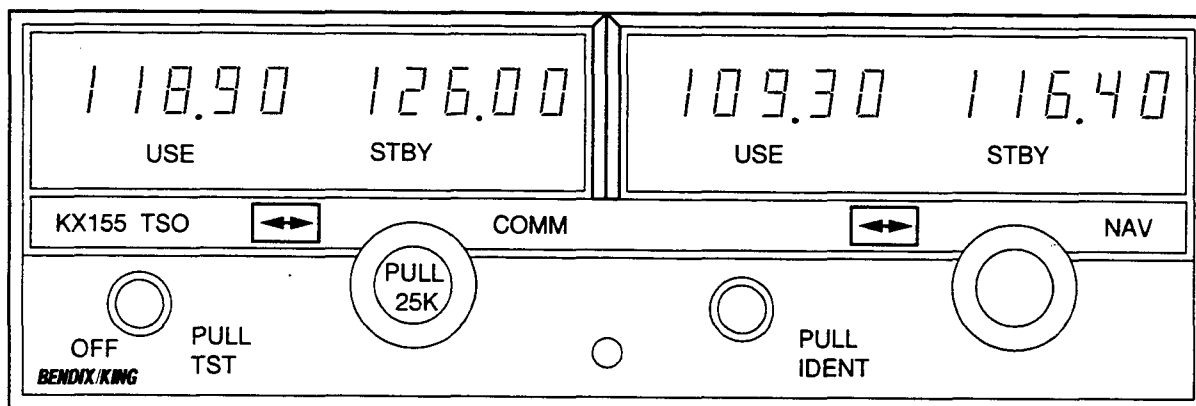

FIGURE 3-1 KX 155/165 CONTROL FUNCTION

BENDIX/KING**KX 155/165
VHF NAV/COMM TRANSCEIVER****3.2 KI 202/203/204, KI 206/208/209 INDICATOR CONTROLS AND FUNCTIONS****3.2.1 VOR OPERATION**

Channel the NAV Receiver to the desired VOR and monitor the audio to positively identify the station. To intercept a selected VOR radial, turn the OBS to set the desired radial under the lubber line. The left-right needle will now deflect in the direction of the desired radial. Flying toward needle deflection will bring the aircraft to the desired radial.

To fly inbound toward the station, turn the OBS to center the left-right needle while the To-From is indicating TO. Read the bearing under the lubber line and fly that magnetic course. When the aircraft passes over the station, the To-From will momentarily disappear and then reappear as FROM. This indicates the aircraft is outbound from the station.

3.2.2 LOC OPERATION

Localizer circuitry is energized when the NAV Receiver is channeled to an ILS frequency. The VOR/LOC flag will be out of view when the signal is usable. Corrections for approach should be made toward the needle, as in VOR, but due to increased sensitivity, corrections are smaller. When flying inbound on a back course, deflection of the needle will be reversed.

3.2.3 GLIDESLOPE OPERATION

Glideslope operation is much the same as the Localizer just discussed. An Up deflection of the needle indicates the aircraft is below desired glidepath. The pilot must fly toward the needle for correction. A warning flag is provided to indicate usable signal conditions.

3.2.4 UNIT CONTROL FUNCTIONS

The following figure (Figure 3-2) displays the control functions for the KI 204/206/209. The KI 202/203/208 differs in not having a glideslope needle or flag. The KI 207 differs in not having an OBS or Azimuth card.

BENDIX/KING

**KX 155/165
VHF NAV/COMM TRANSCEIVER**

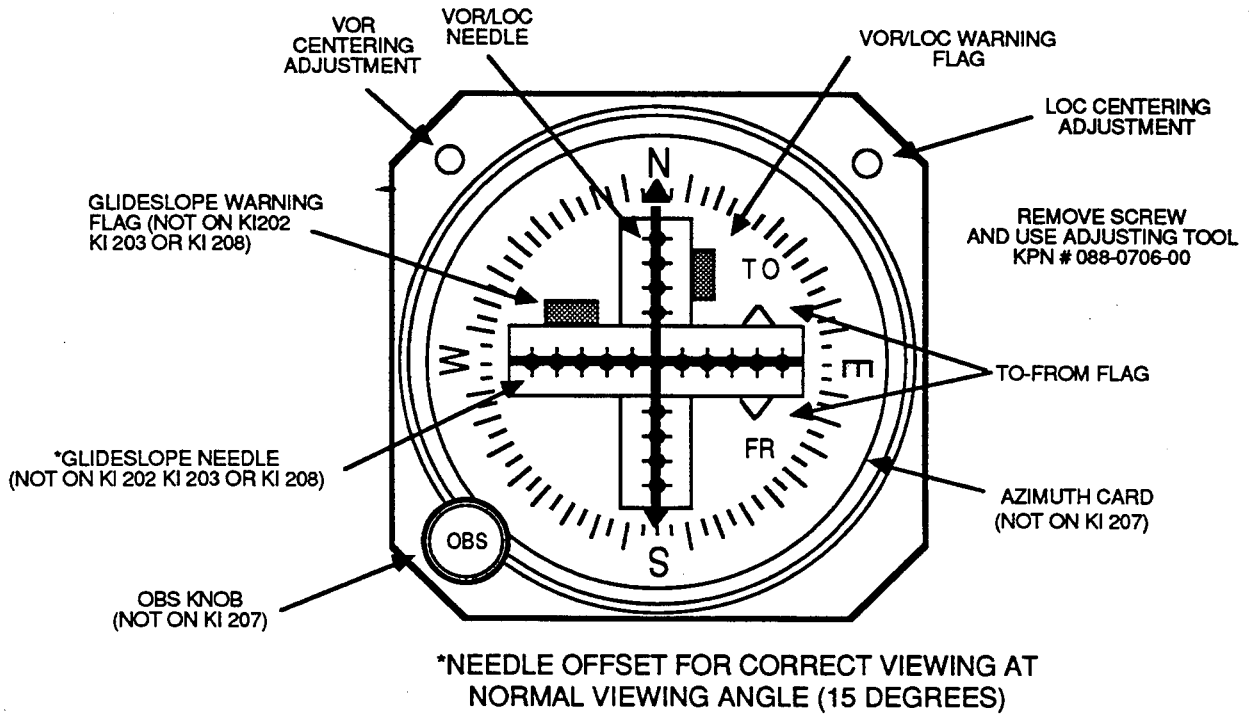

FIGURE 3-2 KI 202/203/204/206/207/208/209
TYPICAL INDICATOR MARKINGS

UP793797

BENDIX/KINGKX 155/165
VHF NAV/COMM TRANSCEIVER

3.3 KI 525A INDICATOR CONTROLS AND FUNCTIONS

3.3.1 VOR/LOC AND GLIDESLOPE OPERATION

Set the navigation receiver to the desired VOR/LOC station and rotate the course select knob to adjust the selected course pointer to the desired course radial. When a usable navigation signal is received by the KI 525A the NAV warning flag will disappear from view.

For an ILS approach, tune the navigation receiver to the desired frequency. The glideslope pointer will deflect into view after a 2 to 10 second delay if a usable glideslope signal is received. The glideslope pointer indicates the relative position of the glideslope path with respect to the aircraft.

For LOC operation, tune the navigation receiver to the desired frequency and set the pointer to the selected inbound localizer course. The position of the deviation bar with respect to the symbolic aircraft indicates the relative position of the selected course. For backcourse operation, set the course pointer to the inbound localizer front course. The deviation bar position relative to the symbolic aircraft then represents the position of the backcourse with respect to the aircraft.

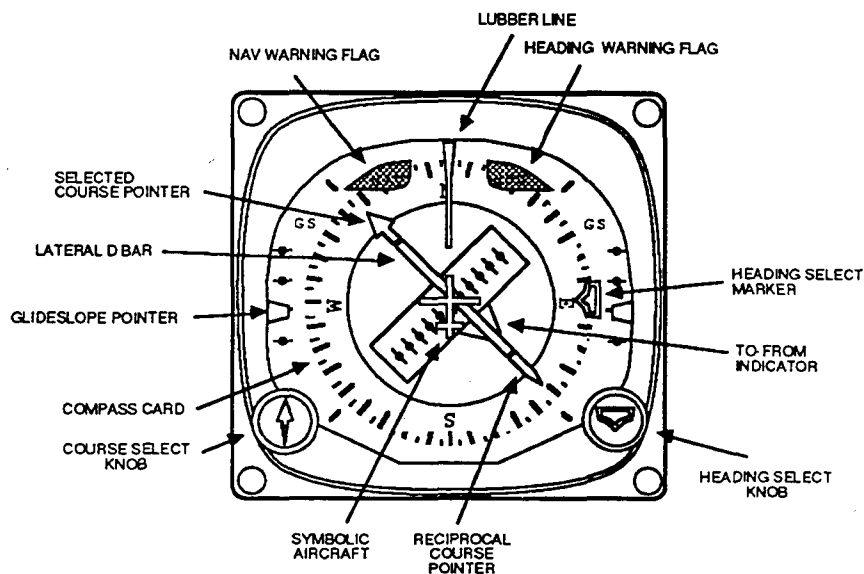

FIGURE 3-3 KI 525A INDICATOR AND CONTROLS

BENDIX/KING

KX 155/165
VHF NAV/COMM TRANSCEIVER

3.4 KNI 229 RMI OPERATION

The KNI 229 Radio Magnetic Indicator provides bearing information to both ADF and VOR stations by means of two pointers, each of which is read against the compass card. The servo drive compass card displays heading information derived from ARINC type X, Y, Z, compass headings. The double pointer is dedicated solely to a ADF DC SIN/COS source. The single pointer is assigned to VOR information.

NOTE: The single pointer can be switched between VOR and ADF by means of an external switch as explained in the installation manual of the KNI 229.

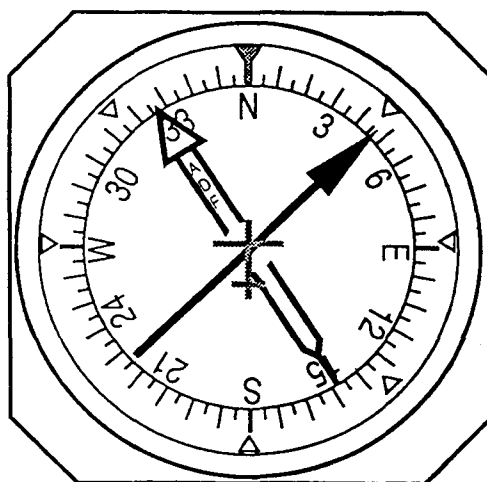

FIGURE 3-4 KNI 229 RADIO MAGNETIC INDICATOR

3.5 KPI 552 PICTORIAL NAVIGATION INDICATOR

The KPI 552 pictorial navigation indicator is a 4 inch, internally-lighted, panel-mounted instrument that presents an aircraft compass heading with respect to magnetic north, selected heading, selected course, and automatic bearing of the ADF or RMI station selected. Heading, selected heading, selected course, and the ADF or RMI station bearing are read against a servo driven compass card.

BENDIX/KING**KX 155/165
VHF NAV/COMM TRANSCEIVER**

The drive electronics for these displays are contained within the indicator. Selected course and selected headings may be positioned manually with the appropriate knob on the lower front bezel. HDG selection may be also made remotely with the HDG select knob on the KMC 340 when the KPI 552 is part of the KFC 300 system.

Meter movements display glideslope deviation, course deviation, TO-FROM indication, and operate warning flags or shutters that monitor compass, navigation and glideslope valid signals.

Refer to the KPI 552/553/553A installation manual, P/N 006-00173-XXXX, for complete KPI 552 installation information.

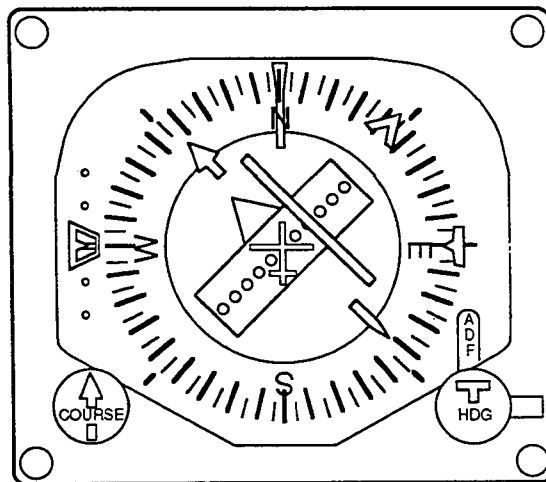

FIGURE 3-5 KPI 552 PICTORIAL NAVIGATION INDICATOR

BENDIX/KINGKX 155/165
VHF NAV/COMM TRANSCEIVER

3.6 KPI 553A PICTORIAL NAVIGATION INDICATOR

The KPI 553A Pictorial Navigation Indicator is a 4-inch, internally-lighted, panel mounted instrument and is part of the Bendix/King KFC 300 Integrated Flight System. It presents a plan view of the aircraft with respect to magnetic north, selected heading, selected course, and the automatic bearing of the ADF/RMI station selected. Heading, selected heading, selected course, and the ADF or RMI station bearing are read against a servo driven compass card.

The servo drive electronics for the compass servo loop and ADF/RMI servo loop are contained within the indicator. Provision has been made for remote positioning of selected heading. The amplifier for this drive is self-contained.

Meter movements display glideslope deviation, course deviation, TO-FROM indication, and operate warning flags or shutters that monitor compass, navigational and glideslope valid signals.

In addition, the unit has a navigation display located at the top of the front bezel. This readout displays numerical data and appropriate annunciation.

The unit displays distance to VORTAC or waypoint on the left-hand portion of the display, indicated by the legend NM. Range is indicated to the nearest tenth of a nautical mile from 0 to 99.9 nautical miles and to the nearest nautical mile from 100 to 389 nautical miles.

Ground speed is shown by the middle portion of the display, indicated by the legend KT. It is indicated to the nearest knot from 0 to 999 knots. DME ground speed is only accurate when flying a direct course to or from the VORTAC or waypoint.

Time-to-station is displayed by the right-hand portion of the display, indicated by the legend MIN. It is displayed to the nearest minute from 0 to 99 minutes, with 99 indicated for any time greater than 99 minutes. Time-to-station is only accurate for a course directly to or from a VORTAC or waypoint.

Radar altitude is shown as dashed lines on the middle display between 1250 and 1000 feet, and numerically to the nearest 10 feet from 990 to 0 feet. The appearance of the letters AL on the right hand display and the blanking of KT and MIN indicate radar altitude information is being displayed.

The KPI 553A digital display also indicates the source of the frequency information which is controlling the DME. Between the left and middle displays, a 1 (one) is displayed when the DME function switch is set to N1. Likewise 2 (two) is displayed when N2 is selected.

BENDIX/KINGKX 155/165
VHF NAV/COMM TRANSCEIVER

Switching to HOLD will store the channeling information from the NAV frequency selector which was previously selected. No frequency selector thereafter affects the DME, and any frequency selector may then be set to another frequency. The DME will remain on the frequency being stored until N1 or N2 is again selected. 1H or 2H on the display indicates a HOLD setting, as well as the NAV frequency selector whose setting was held.

The indicator will display RNV when the displayed range, ground speed, and time-to-station are derived from an area navigation system. This legend will flash if an RNAV is on but not selected, even if another active RNAV is selected. It also flashes when HOLD mode is selected. The display is blanked when RNV is flashing.

The indicator will display all dashes if power is either turned on or momentarily lost during frequency HOLD, and normal operation may be restored by selecting N1 or N2.

Readout brightness is automatically controlled with respect to cockpit ambient lighting by a photocell located to the left of the digital readout.

Refer to the KPI 552/553/553A installation manual, P/N 006-00173-XXXX, for completed KPI 553A installation information.

3.6.1 KPI 553A (Figure 3-6)

The functions described for the KPI 552 are applicable to the KPI 553A. Additional readouts of the KPI 553A are tabulated below.

- | | |
|------------------------------------|---|
| A. Distance Display | The left hand portion of the display shows distance to the VOR or waypoint, as determined by the function switch (KCU 565A or KNS 81). |
| B. Groundspeed or Altitude Display | The middle portion of the display shows Groundspeed (KT) or Radar Altitude (AL) as indicated by illumination of the KT legend in the middle display or by the letters AL appearing in the right hand portion of the display and the blanking of KTS and MIN. Radial information is also displayed during KNS 81 RAD mode. |
| C. DME Function Indicator | The middle portion of the display shows 1 or 2 to denote the NAV channel in use. A letter H denotes a HOLD state. |

BENDIX/KING

**KX 155/165
VHF NAV/COMM TRANSCEIVER**

- D. Time-to-Station Display The right hand portion of the display shows Time-to-Station indicated by legend MIN or letters AL to indicate Altitude Display. A F character is displayed during KNS 81 RAD mode.

- E. RNV Annunciator The right hand portion of the display contains the legend RNV which indicates validity of displayed RNAV/DME data.

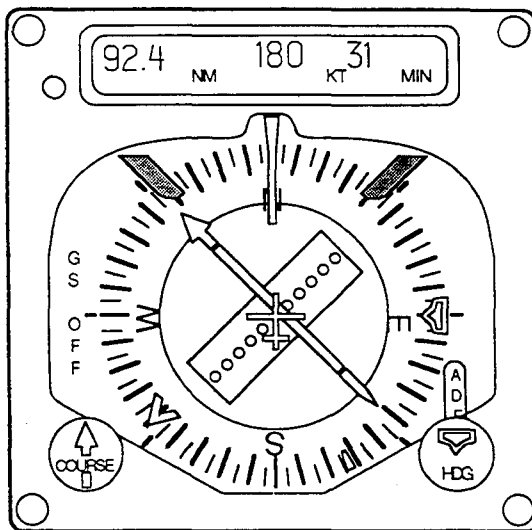

FIGURE 3-6 KPI 553A PICTORIAL NAVIGATION INDICATOR

