



TruTrak Flight Systems, Inc.

STC SA04231CH

Instructions for Continued Airworthiness

Document Number: TruTrak Doc: 181

Rev. J

Date: 12 September, 2019

TruTrak Flight Systems, Inc.

1488 S Old Missouri Rd

Springdale, AR. 72764

Aircraft Make: _____

Aircraft Model: _____

Aircraft Serial Number: _____

22-80-00

Page 1 of 111

TruTrak Doc: 181 Rev.J

STC SA04231CH
Instructions for Continued Airworthiness

Table of Contents

1. 1. Document Information	5
1.1. Document Revision History	5
1.2. Referenced Publications.....	5
2. 2. Introduction	6
2.1. Introductory Information	6
2.2. System Installed Components.....	6
2.3. Vizion Autopilot System	7
2.4. Vizion Autopilot Basic Operation	8
3. 3. Airworthiness Limitations	10
4. 4. Recommended Inspection Practices	11
4.1. Task 04-24-01 - Operational Check.....	11
4.2. Task 04-24-02 - Cleaning.....	12
4.3. Task 04-24-03 – Backlight Inspection.....	12
4.4. Task 04-24-04 – Airspeed Check.....	12
4.5. Task 04-24-05 – Inspection of the Roll Servo and Roll Servo Installation	13
4.6. Task 04-24-06 – Inspection of the Pitch Servo and Pitch Servo Installation	14
4.7. Task 04-24-07 – Inspection of the 8000-177 Link Sensor.....	15
4.8. Task 04-24-08 – Inspection of the autopilot placard	15
5. 5. Vizion Autopilot Controller – Removal Installation Configuration	16
5.1. Task 05-23-01 – Removal of Vizion 2-Inch Round (8000-174 / 8000-183).....	16
5.2. Task 05-23-02 – Installation of Vizion 2-Inch Round (8000-174 / 8000-183)	17
5.3. Task 05-23-03 – Configuration of Vizion 2-Inch Round (8000-174 / 8000-183).....	19
5.4. Task 05-23-04 – Removal of Vizion Flat (8000-175 / 8000-185).....	19
5.5. Task 05-23-05 – Installation of Vizion Flat (8000-175 / 8000-185)	21
5.6. Task 05-23-06 – Configuration of Vizion Flat (8000-175 / 8000-185).....	22
5.7. Task 05-23-07 – Removal of Vizion 3-Inch Round (8000-176 / 8000-184).....	23
5.8. Task 05-23-08 – Installation of Vizion 3-Inch Round (8000-176 / 8000-184)	24
5.9. Task 05-23-09 – Configuration of Vizion 3-Inch Round (8000-176 / 8000-184).....	26
5.10. Task 05-23-10 – Removal of CWS Switch.....	26
5.11. Task 05-23-11 – Installation of CWS Switch	27
6. 6. Autopilot Controller IPC	28
7. 7. Placarding	29
7.1. Task 07-24-01 – Installation of the autopilot placard	29
8. 8. Troubleshooting	30
8.1. Introduction.....	30
8.2. Airspeed Check.....	30
8.3. Displayed Alert Messages	30
8.4. Troubleshooting Guide	31
9. 9. AML STC SA04231CH	33
10. 10. Appendix A – Cessna 172 F - S Models	34

10.1. Cessna 172 F – S Additional Installation Components.....	34
10.2. Cessna 172 F – S Equipment Locations.....	35
10.3. Task 10-23-01 – Cessna 172 F – S Autopilot Configuration.....	37
10.4. Task 10-23-02 – Removal of Cessna 172 F – S Roll Servo.....	37
10.5. Task 10-23-03 – Installation of Cessna 172 F – S Roll Servo.....	38
10.6. Task 10-23-04 – Removal of Cessna 172 F – S Pitch Servo.....	40
10.7. Task 10-23-05 – Installation of Cessna 172 F – S Pitch Servo.....	41
10.8. Task 10-23-06 – Removal of Cessna 172 F – S Link Sensor.....	42
10.9. Task 10-23-07 – Installation of Cessna 172 F – S Link Sensor.....	43
11. 11. Appendix B – Cessna 177 Models.....	45
11.1. Cessna 177 Additional Installation Components.....	45
11.2. Cessna 177 Equipment Locations.....	46
11.3. Task 11-23-01 – Cessna 177 Autopilot Configuration.....	47
11.4. Task 11-23-02 – Removal of Cessna 177 Roll Servo.....	48
11.5. Task 11-23-03 – Installation of Cessna 177 Roll Servo.....	48
11.6. Task 11-23-04 – Removal of Cessna 177 Pitch Servo.....	51
11.7. Task 11-23-05 – Installation of Cessna 177 Pitch Servo.....	52
11.8. Task 11-23-06 – Removal of Cessna 177 Link Sensor.....	54
11.9. Task 11-23-07 – Installation of Cessna 177 Link Sensor.....	55
12. 12. Appendix C – Cessna 175/172 All Models.....	57
12.1. Cessna 175/172 All Models Additional Installation Components.....	57
12.2. Cessna 175/172 All Models Equipment Locations.....	58
12.3. Task 12-23-01 – Cessna 175/172 All Models Autopilot Configuration.....	59
12.4. Task 12-23-02 – Removal of Cessna 175/172 All Models Roll Servo.....	60
12.5. Task 12-23-03 – Installation of Cessna 175/172 All Models Roll Servo.....	61
12.6. Task 12-23-04 – Removal of Cessna 175/172 All Models Pitch Servo.....	63
12.7. Task 12-23-05 – Installation of Cessna 175/172 All Models Pitch Servo.....	64
12.8. Task 12-23-06 – Removal of Cessna 175/172 All Models Link Sensor.....	66
12.9. Task 12-23-07 – Installation of Cessna 175/172 All Models Link Sensor.....	66
13. 13. Appendix D – Piper PA-28.....	68
13.1. Piper PA-28 Additional Installation Components.....	68
13.2. PA-28 Equipment Locations.....	69
13.3. Task 13-23-01 – Piper PA-28 Autopilot Configuration.....	70
13.4. Task 13-23-02 – Removal of Piper PA-28 Roll Servo.....	70
13.5. Task 13-23-03 – Installation of Piper PA-28 Roll Servo.....	71
13.6. Task 13-23-04 – Removal of Piper PA-28 Pitch Servo.....	73
13.7. Task 13-23-05 – Installation of Piper PA-28 Pitch Servo.....	74
13.8. Task 13-23-06 – Removal of Piper PA-28 Link Sensor.....	74
13.9. Task 13-23-07 – Installation of Piper PA-28 Link Sensor.....	75
14. 14. Appendix E – Cessna 180, 182-182D, 185.....	77
14.1. Cessna 180, 182-182D, 185 Additional Installation Components.....	77
14.2. Cessna 180, 182-182D, 185 Equipment Locations.....	78
Task 14-23-01 – Cessna 180, 182-182D, 185 Autopilot Configuration.....	79
Task 14-23-02 – Removal of Cessna 180, 182-182D, 185 Roll Servo.....	79
Task 14-23-03 – Installation of Cessna 180, 182-182D, 185 Roll Servo.....	80

Task 14-23-04 – Removal of Cessna 180, 182-182D, 185 Pitch Servo.....	83
Task 14-23-05 – Installation of Cessna 180, 182-182D, 185 Pitch Servo.....	83
Task 14-23-06 – Removal of Cessna 180, 182-182D, 185 Link Sensor.....	84
Task 14-23-07 – Installation of Cessna 180, 182-182D, 185 Link Sensor.....	85
15. 15. Appendix F – Cessna 182E-182T	88
15.1. Cessna 182E-182T Additional Installation Components.....	88
15.2. Cessna 182E-182T Equipment Locations.....	89
15.3. Task 14-23-01 – Cessna 182E-182T Autopilot Configuration.....	90
15.4. Task 15-23-02 – Removal of Cessna 182E-182T Roll Servo.....	90
15.5. Task 15-23-03 – Installation of Cessna 182E-182T Roll Servo.....	91
15.6. Task 15-23-04 – Removal of Cessna 182E-182T Pitch Servo.....	94
15.7. Task 15-23-05 – Installation of Cessna 182E-182T Pitch Servo.....	94
15.8. Task 15-23-06 – Removal of Cessna 182E-182T Link Sensor.....	95
15.9. Task 15-23-07 – Installation of Cessna 182E-182T Link Sensor.....	96
16. 16. Appendix G – Piper PA-32	99
16.1. Piper PA-32 Additional Installation Components.....	99
16.2. PA-32 Equipment Locations.....	100
16.3. Task 16-23-01 – Piper PA-32 Autopilot Configuration.....	101
16.4. Task 16-23-02 – Removal of Piper PA-32 Roll Servo.....	101
16.5. Task 16-23-03 – Installation of Piper PA-32 Roll Servo.....	102
16.6. Task 16-23-04 – Removal of Piper PA-32 Pitch Servo.....	107
16.7. Task 16-23-05 – Installation of Piper PA-32 Pitch Servo.....	108
16.8. Task 16-23-06 – Removal of Piper PA-32 Link Sensor.....	108
16.9. Task 13-23-07 – Installation of Piper PA-32 Link Sensor.....	109

1. Document Information

1.1. Document Revision History

Rev	Description	Pages Modified	Pages	Date
0	Initial Release	All	36	6-20-17
A	Addressed FAA comments and improved instructions	1-3, 5-8, 10, 12-16, 18-20, 23-30, 32, 33, 35, 39, 42, 44-46, 48-60	60	7-11-17
B	Added 24 Volt Servo	5, 14, 23, 26, 33, 35, 54, 56, 57, 59, 60	60	9-8-17
C	Reformatted and added C177 instructions	All	74	11-1-17
D	Added Appendix C for C175/172 instructions, removed duplicate IPC diagrams, Added referenced publications section	All	75	1-5-18
E	Added Appendix D for PA-28	75-88	88	1-15-18
F	Added Appendix E and Appendix F, Reformatted	All	98	8-10-18
G	Added Appendix G	98-111	111	10-30-18
H	Corrected TOC and footer, inserted TruTrak STC and added TruTrak address on cover page		111	11-7-18
I	Added BK part numbers, updated contact information, and changes for PV.40 software	6, 9, 13, 14, 16, 17, 19, 21, 22, 24, 26	111	5-15-19
J	Added inspection for capstans and pulleys	14,15	111	9-12-19

1.2. Referenced Publications

- 1.2.1. Vizion PMA Installation Guide (166)
- 1.2.2. Vizion PMA Installation C172 Appendix A (168)
- 1.2.3. Vizion PMA Installation Guide - C177 - Appendix B (169)
- 1.2.4. Vizion PMA Installation Guide C175-C172 All Models Appendix C (242)
- 1.2.5. Vizion PMA Installation Guide PA-28 Appendix D (242)

- 1.2.6. Vizion PMA Installation C182, C182-C182D, C185 Appendix E (255)
 - 1.2.7. Vizion PMA Installation C182E-C182T Appendix F (256)
 - 1.2.8. Vizion PMA Installation Guide PA-32 Appendix G (267)
- (latest FAA approved revisions)

2. Introduction

2.1. Introductory Information

IMPORTANT NOTE: For the entirety of this manual the term “Vizion Autopilot” may be considered interchangeable for “Vizion 2-inch round” or “Vizion Flat” or “Vizion 3-inch round” except where specifically noted. Changes to these instructions specific to the Vizion Flat may be found in Appendix A of this document. Changes to these instructions specific to the Vizion 3-inch round may be found in Appendix B of this document.

These Instructions for Continued Airworthiness (ICA) provide instructions necessary for authorized personnel to inspect and maintain the Vizion Autopilot System. This document should be printed and included with the aircraft Instructions for Continued Airworthiness and arranged for easy and practical use.

It should be noted that many of the Maintenance Tasks and Inspections included in this manual do not meet the definition of preventative maintenance and therefore require FAA certification to perform. Users of this manual should refer to 14 CFR Part 43 to ensure that they hold the require credentials to legally perform maintenance on a FAA certified aircraft.

2.2. System Installed Components

The Vizion Autopilot System installation includes the following components, which are all required and are approved under this STC:

Main Autopilot Display / Controller:

EITHER:

8000-174 or 8000-183 Vizion 2-inch round

OR:

8000-175 or 8000-185 Vizion Flat

OR:

8000-176 or 8000-184 Vizion 3-inch round

EITHER:

8100-064 12 Volt 60 inch/lb Servo (2 required)

OR:

8100-065 24 Volt 60 inch/lb Servo (2 required)

8000-177 Link Sensor

Other than the optional three different main autopilot display / controller and two different servo options, installation of all parts listed above is mandatory under this approval.

The Vizion 2 Inch round fits in a standard 2-1/4" instrument hole and is 2.5" x 2.5" x 5.4" deep. Vizion Flat mounts in a 4" x 1.4" octagonal cutout and is 4.3" wide x 1.6" tall x 5.4" deep. The Vizion 3-inch round fits in a standard 3-1/8" instrument hole and is 3.25" x 3.25" x 5.4" deep.

The Vizion autopilot system-wide power requirement on a 14-volt system is 40 watts typical and 50 watts maximum. The autopilot controller can operate on 10-30 volts, the servos are specific for 12-volt system or 24-volt systems. On a 12-volt system, this translates to about 3.5 amps of maximum current draw. Detailed wiring description is found in each aircraft specific appendix of this document. The Vizion autopilot system does not provide any primary instrument display; all displayed information is only intended to show the pilot what the autopilot system is attempting to follow.

2.3. Vizion Autopilot System

The TruTrak Vizion autopilot is a two-axis autopilot, which connects to the ailerons and elevator. The autopilot controller / display unit contains all sensors needed for proper control of the aircraft. The controller connects to aircraft pitot and static system for airspeed and altitude sensing. The pilot interfaces with the controller / display unit as well as with an emergency level button (AP Level) and with a control wheel steering switch (CWS). The CWS switch serves not only as the CWS function but also as the autopilot cutoff switch.

The controller / display unit connects to a 60-in/lb capable servo for roll axis control and a 60-in/lb capable servo for pitch axis control. These servos are identical and may be interchanged without harm.

Trim sensing is done by a separate sensor, which is contained in the pitch servo pushrod.

In all installations with at least a basic GPS, the following features are available; other modes may be possible depending on installed equipment:

Emergency Level

Control Wheel Steering
Track Select
Bank Angle Select
Vertical Speed Select
Altitude Hold
Altitude Select

The Vizion autopilot does not replace any of the primary aircraft flight instruments; it is the pilot's primary responsibility to fly the aircraft in accordance with the information displayed on the primary flight instruments.

In the case of temporary power loss, the autopilot will be available for use within three (3) seconds of power being reapplied to the system.

2.4. Vizion Autopilot Basic Operation

GPS Status

GPS OK and flashing * or + means GPS communication is working properly and GPS has a fix.

Engage Autopilot

Momentarily Press knob

or

Momentarily Press AP LVL button

Disengage Autopilot

Press knob for 2 seconds

or

Momentarily Press CWS switch

or

Remove power using AP MASTER or AP circuit breaker

Lateral Modes

Track Mode

Rotate knob to select desired track

Bank Angle Mode (If no GPS signal)

Rotate knob to select desired bank angle

Vertical Modes

Altitude Hold Mode

Automatically entered when target altitude is reached

or

Momentarily Press ALT button ->

Momentarily Press knob (without adjusting target altitude)

Altimeter / Barometer Sync

Momentarily Press ALT button two times ->

Set altitude to match barometer corrected aircraft altimeter

Momentarily Press knob

Altitude Select Mode

Momentarily Press ALT button ->

Select altitude, Momentarily Press knob ->

Select vertical speed, Momentarily Press knob

Updated Versions of this Manual

Updated versions of this manual can be obtained by contacting TruTrak Flight Systems at (479) 751-0250 or at www.trutrakap.com.

3. Airworthiness Limitations

The Airworthiness Limitations Section is FAA approved and specifies maintenance required under 14 CFR §§ 43.16 and 91.403 of the Federal Aviation Regulations unless an alternative program has been FAA approved.

There are no new (or additional) airworthiness limitations associated with this equipment and / or installation.

FAA Approved

Timothy Smyth

Manager, Chicago Aircraft Certification Office

Federal Aviation Administration

4. Recommended Inspection Practices

The Vizion autopilot system shall be inspected per the tasks below. Tasks 04-24-01, 04-24-03, 04-24-05, 04-24-06, 04-24-07, and 04-24-08 must be performed every 100 hours of operation or at each annual inspection. Task 04-24-04 must be performed every 24 calendar months in conjunction with the pitot static check required in 14 CFR 91.411 and documented in the aircraft logs as required by 14 CFR 43.9. All other maintenance is on condition.

The components constituting Vizion Autopilot System have no field-serviceable components. If the component fails any of the required testing in section 4 of this manual or malfunctions in any other manner, refer all servicing to properly trained and certificated technicians. No special equipment is required for servicing.

4.1. Task 04-24-01 - Operational Check

The autopilot operation must be verified every 100 hours of operation or at each annual inspection according to the following guidelines Power up the unit by turning on the autopilot master to which it is connected. Ensure the unit powers up correctly and that the display is clear and readable. If aircraft battery power is not sufficient to perform the test below, connect aircraft to ground power.

With the unit powered on, verify the following:

- 4.1.1. Ensure the display reads AP OFF within five (5) seconds of applying power via the autopilot master.
- 4.1.2. Ensure the autopilot altimeter readout is stable, to do this momentarily press and release the ALT button twice (2). The current altitude will be visible on this screen, it may vary plus or minus 5 to 10 feet, this is normal.
- 4.1.3. Return to the main autopilot screen with a momentary press and release of the MODE button.
- 4.1.4. Engage the autopilot with a momentary press and release of the knob. Using the knob to command a right bank of 15 degrees, verify the roll servo moves the primary flight controls in the correct direction.
- 4.1.5. Using the knob, command a left bank of 15 degrees, verify the roll servo moves the primary flight controls in the correct direction.
- 4.1.6. With the autopilot still engaged, momentarily press and release the knob to move the cursor to SVS, rotate clockwise to command a positive vertical speed of 500 fpm. Verify the pitch servo moves the primary flight controls in the correct direction.
- 4.1.7. If the cursor has moved back to SEL, then momentarily press and release the knob to move the cursor to SVS, rotate counter-clockwise to command a negative

vertical speed of 500 fpm. Verify the pitch servo moves the primary flight controls in the correct direction.

4.1.8. Disengage the autopilot with a momentary press and release of the CWS switch, ensure the servos properly disengage and that the primary flight controls are movable throughout their entire range of motion.

4.1.9. Ensure that the autopilot can be engaged using the Emergency Level (AP Level) button. Engage using a momentary press and release of the AP Level button.

4.1.10. Remove power from the autopilot system using the AP Master switch.

4.1.11. Verify all controls move freely.

If the Unit fails any of the above tests refer to Section 8 of this manual.

4.2. Task 04-24-02 - Cleaning

The autopilot controller can be wiped clean with a soft, dry cloth. No cleaning agents are necessary.

4.3. Task 04-24-03 – Backlight Inspection

The autopilot backlight operation must be verified every 100 hours of operation or at each annual inspection according to the following guidelines. Power up the unit by turning on the autopilot master to which it is connected. If aircraft battery power is not sufficient to perform the test below, connect aircraft to ground power.

4.3.1. Cover the photocell on the bezel with a thumb or opaque object (electrical tape works well).

4.3.2. Ensure the display dims appropriately for night usage.

4.4. Task 04-24-04 – Airspeed Check

The accuracy of the airspeed calibration of the Vizion autopilot must be verified every 24 calendar months in conjunction with the pitot static check required in 14 CFR 91.411 and documented in the aircraft logs as required by 14 CFR 43.9. This is to ensure proper operation of the minimum and maximum airspeed protections. First, the currently set minimum and maximum airspeed values have to be recorded from the autopilot setup mode. If aircraft battery power is not sufficient to perform the test below, connect aircraft to ground power. Use the following guidelines to obtain the current airspeed settings:

4.4.1. Begin with the autopilot master off.

4.4.2. Press and hold the KNOB of the autopilot in while turning on the autopilot master.

4.4.3. Once the master is on, release the KNOB. Momentarily press and release the ALT button twice (if software version PV.30, use KNOB instead of ALT button) to cycle to SETUP ENABLE.

4.4.4. Rotate the knob to set that value to 10.

4.4.5. Momentarily press and release the ALT button (if software version PV.30, use KNOB instead of ALT button) to exit.

4.4.6. Press and hold the ALT button to access the vertical setup menu.

4.4.7. Momentarily press and release ALT to cycle to MIN AIRSPD. Record value shown, this value is in knots indicated airspeed.

4.4.8. Momentarily press and release ALT again to cycle to MAX AIRSPD. Record value shown, this value is in knots indicated airspeed.

4.4.9. Momentarily press and release KNOB to exit the setup.

4.4.10. Engage the autopilot with a momentary press and release of the knob. Use the following guidelines to verify the airspeed:

4.4.11. Perform a pitot system check on the aircraft. Set the pressure box to a corresponding airspeed equal to the autopilot minimum airspeed setting.

4.4.12. Slowly decrease the pitot pressure until MIN AS flashes on the upper right quadrant of the autopilot display. Ensure the airspeed reading on the box is within +/-5 knots of the recorded minimum airspeed value.

4.4.13. Slowly increase the pitot pressure until MAX AS flashes on the upper right quadrant of the autopilot display. Ensure the airspeed reading on the box is within +/- 5 knots of the recorded maximum airspeed value.

4.4.14. Disengage the autopilot with a momentary press and release of the CWS button.

The autopilot backlight operation must be verified every 100 hours of operation or at each annual inspection according to the following guidelines.

4.5. Task 04-24-05 – Inspection of the Roll Servo and Roll Servo Installation

The autopilot roll servo (part number 8100-064, 8100-065, 8100-078, or 8100-079) and roll servo installation must be inspected every 100 hours of operation or at each annual inspection according to the following guidelines. If aircraft battery power is not sufficient to perform the test below, connect aircraft to ground power.

4.5.1. With the autopilot powered up but not engaged, move the primary flight controls (both pitch and roll axes) through their full ranges of motion. There should be no residual friction added to the controls by the autopilot servos. Controls should move freely and without catching or grinding.

- 4.5.2. Inspect roll servo mounting brackets for signs of wear or structural damage.
- 4.5.3. Verify integrity of roll servo pushrod and rod end bearings. Inspect capstan, pulleys, pulley bearings, and bridal cable for excessive wear. Lubricate rod end bearings with MIL-C-81309D Type III (LPS 2 meets this requirement).
- 4.5.4. Ensure rod end bearing jam nuts are torqued to 20-25 inch pounds.
- 4.5.5. Ensure pushrod rod end bearing bolt connection to roll servo output arm is torqued to 20-25 inch pounds.
- 4.5.6. Ensure roll servo mounting bolts are torqued to 20-25 inch pounds.
- 4.5.7. Ensure roll servo mounting brackets screws are torqued to 20-25 inch pounds.
- 4.5.8. Verify no chaffing or damage to roll servo wiring harness or 9 pin connector.
- 4.5.9. Engage Vizion autopilot with a momentary press and release of the knob.
- 4.5.10. Verify that roll servo can be overridden with a moderate force of approximately 15 pounds at a 5-inch arm on the control yoke, which in the judgment of the maintainer is appropriate to the mechanism being checked.
- 4.5.11. Disengage autopilot with a momentary press and release of the CWS button.
- 4.5.12. Power down the autopilot.

4.6. Task 04-24-06 – Inspection of the Pitch Servo and Pitch Servo Installation

The autopilot pitch servo (part number 8100-064, 8100-065, 8100-078, or 8100-079) and pitch servo installation must be inspected every 100 hours of operation or at each annual inspection according to the following guidelines. If aircraft battery power is not sufficient to perform the test below, connect aircraft to ground power.

- 4.6.1. With the autopilot powered up but not engaged, move the primary flight controls (both pitch and roll axes) through their full ranges of motion. There should be no residual friction added to the controls by the autopilot servos. Controls should move freely and without catching or grinding.
- 4.6.2. Inspect pitch servo mounting brackets for signs of wear or structural damage.
- 4.6.3. Inspect pitch clamp for signs of wear or structural damage.
- 4.6.4. Verify integrity of pitch servo pushrod (link sensor) and rod end bearings. Inspect capstan, pulleys, pulley bearings, and bridal cable for excessive wear. Lubricate rod end bearings with MIL-C-81309D Type III (LPS 2 meets this requirement).
- 4.6.5. Ensure rod end bearing jam nuts are torqued to 20-25 inch pounds.

- 4.6.6. Ensure pushrod rod end bearing bolt connection to pitch servo output arm is torqued to 20-25 inch pounds.
- 4.6.7. Ensure pitch servo mounting bolts are torqued to 20-25 inch pounds.
- 4.6.8. Ensure pitch servo mounting bracket bolts are torqued to 20-25 inch pounds.
- 4.6.9. Ensure pitch clamp bolts are torqued to 20-25 inch pounds.
- 4.6.10. Verify no chaffing or damage to pitch servo wiring harness or 9 pin connector.
- 4.6.11. Verify no chaffing or damage to the link sensor wiring harness or connectors.
- 4.6.12. Engage Vizion autopilot with a momentary press and release of the knob.
- 4.6.13. Verify that pitch servo can be overridden with a moderate force of approximately 30 pounds on the control yoke, which in the judgment of the maintainer is appropriate to the mechanism being checked. Note that the force will differ in push versus pull on the yoke due to the weight of the elevator.
- 4.6.14. Disengage autopilot with a momentary press and release of the CWS button.
- 4.6.15. Power down the autopilot.

4.7. Task 04-24-07 – Inspection of the 8000-177 Link Sensor

The autopilot link sensor must be inspected every 100 hours of operation or at each annual inspection according to the following guidelines. If aircraft battery power is not sufficient to perform the test below, connect aircraft to ground power.

- 4.7.1. Engage the autopilot.
- 4.7.2. Apply approximately five (5) pounds of force forward on the yoke. Verify that autopilot display annunciates the need for UP trim.
- 4.7.3. Apply approximately five (5) pounds of force aft on the yoke. Verify that autopilot display annunciates the need for DN trim.

4.8. Task 04-24-08 – Inspection of the autopilot placard

The autopilot placard must be inspected every 100 hours of operation or at each annual inspection according to the following guidelines:

- 4.8.1. Ensure that the placard is properly attached to the aircraft panel and located in immediate proximity to the autopilot controller / display unit.
- 4.8.2. Ensure that the placard is readable and not overly faded.
- 4.8.3. If placard begins to peel or become unreadable replace with a new placard using the EXACT phrase below. The placard is shown in Section 7 of this manual:

**AUTOPILOT ALTITUDE LIMITATION – 700 FEET AGL
NOT FOR FLIGHT REFERENCE**

5. Vizion Autopilot Controller – Removal Installation Configuration

5.1. Task 05-23-01 – Removal of Vizion 2-Inch Round (8000-174 / 8000-183)

Removal:

- 5.1.1. Shut down aircraft power and disconnect the aircraft battery.
- 5.1.2. Refer to the Autopilot Controller IPC in Section 6 of this document for illustrated parts catalog.
- 5.1.3. Remove the four (4) 6-32 screws holding the autopilot in the panel.
- 5.1.4. Slide the Vizion autopilot back and out of the instrument panel. Depending on location of the Vizion autopilot in the panel, it may be easier to remove the instrument panel rather than drop the autopilot out from behind the panel.

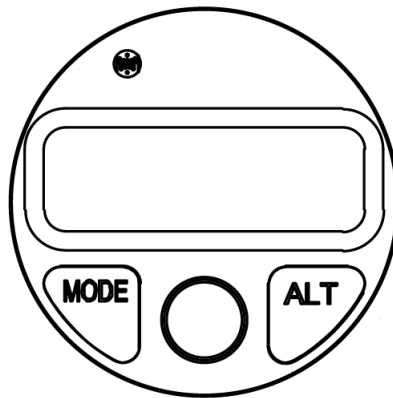

- 5.1.5. Carefully disconnect and cap the 1/8 NPT fittings for the Pitot and Static lines as shown in the figure below. Ensure that both the aircraft pitot and static lines as well as the autopilot pitot and static fittings are capped.

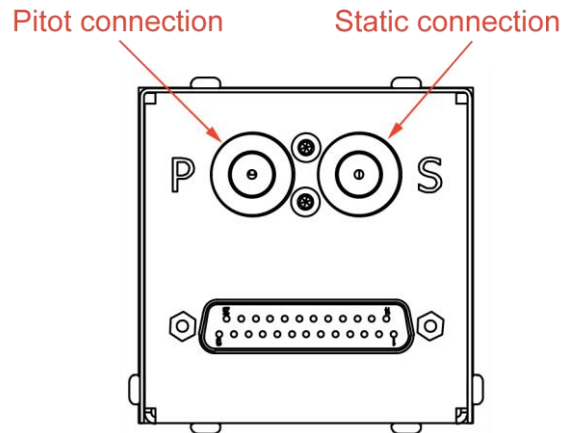

5.1.6. Carefully disconnect the DB25 electrical connector from the back of the unit. This is accomplished by removing the two retention screws and carefully sliding out the connector. See Illustration below:

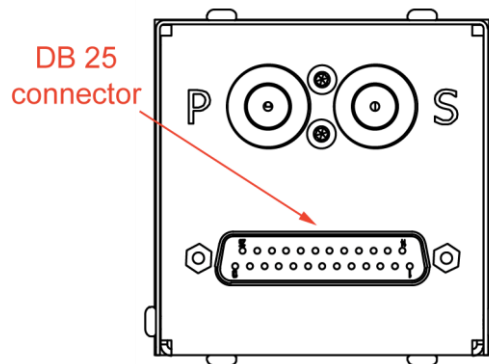

5.1.7. Reconnect aircraft battery.

5.1.8. The unit now should be safely stored until needed for reinstallation.

5.2. Task 05-23-02 – Installation of Vizion 2-Inch Round (8000-174 / 8000-183)

Installation:

5.2.1. Shut down aircraft power and disconnect the aircraft battery.

5.2.2. Refer to the Autopilot Controller IPC in Section 6 of this document for illustrated parts catalog.

5.2.3. Carefully connect the DB25 electrical connector to the back of the unit. Tighten the two retention screws to approximately 12 inch pounds. See Illustration below:

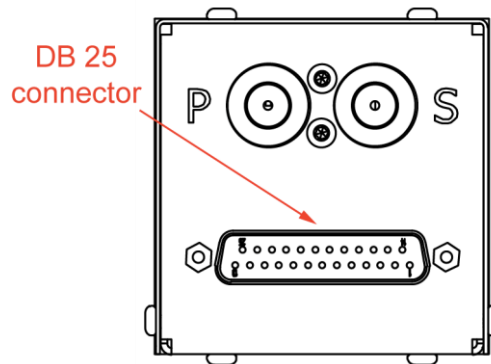

5.2.4. Remove the caps covering the pitot and static ports on the autopilot controller and the caps on the pitot and static lines in the aircraft. Connect the 1/8 NPT pitot line to the 1/8 NPT pitot port and the 1/8 NPT static line to the 1/8 NPT static port. Tighten the pitot and static lines to approximately 12 inch pounds. Illustration below:

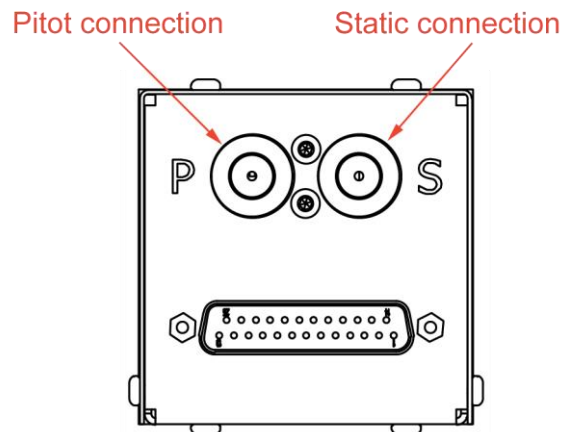

5.2.5. Slide the Vizion autopilot into the instrument panel hole. Depending on location of the Vizion autopilot in the panel, it may be easier to remove the instrument panel rather than reach up behind the panel to install the autopilot.

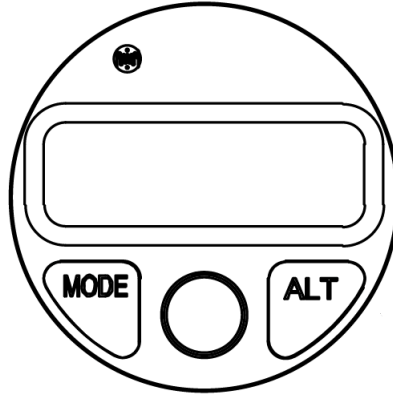

5.2.6. Install the 4 each 6-32 screws holding the autopilot in the panel. Tighten to approximately 12 inch pounds.

5.2.7. Reconnect the aircraft battery and turn on aircraft power.

5.2.8. Configure the unit per the appropriate aircraft model Appendix, Task XX-23-01 (Autopilot Configuration).

5.2.9. If not performed as part of task XX-23-01, perform task 04-24-01 in Section 4 (Operational Check).

5.2.10. Perform and document the Pitot Static System leak check per the appropriate aircraft maintenance manual requirements.

5.3. Task 05-23-03 – Configuration of Vizion 2-Inch Round (8000-174 / 8000-183)

Configuration:

See appropriate aircraft model Appendix for aircraft specific configuration.

5.4. Task 05-23-04 – Removal of Vizion Flat (8000-175 / 8000-185)

Removal:

5.4.1. Shut down aircraft power and disconnect the aircraft battery.

5.4.2. Refer to the Autopilot Controller IPC in section 6 of this document for illustrated parts catalog.

5.4.3. Remove the four (4) 6-32 screws holding the autopilot in the panel.

5.4.4. Slide the Vizion autopilot back and out of the instrument panel. Depending on location of the Vizion autopilot in the panel, it may be easier to remove the instrument panel rather than drop the autopilot out from behind the panel.

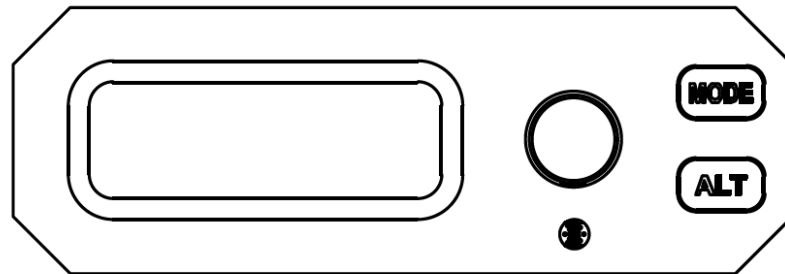

5.4.5. Carefully disconnect and cap the 1/8 NPT fittings for the Pitot and Static lines as shown in the figure below. Ensure that both the aircraft pitot and static lines as well as the autopilot pitot and static fittings are capped.

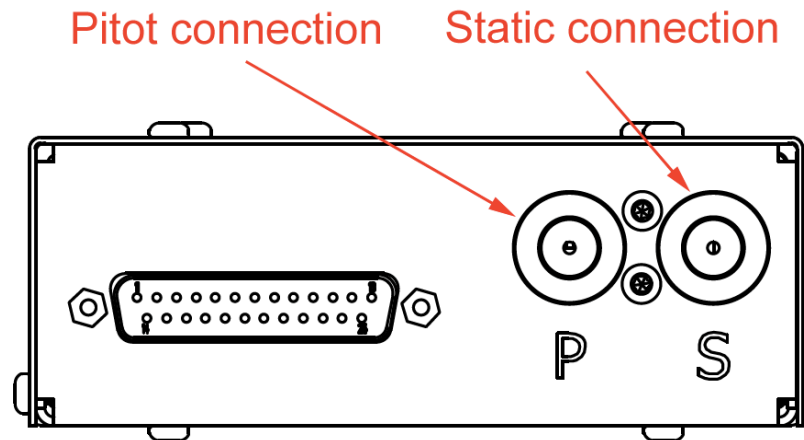

5.4.6. Carefully disconnect the DB25 electrical connector from the back of the unit. This is accomplished by removing the two retention screws and carefully sliding out the connector. See Illustration below:

DB 25
connection

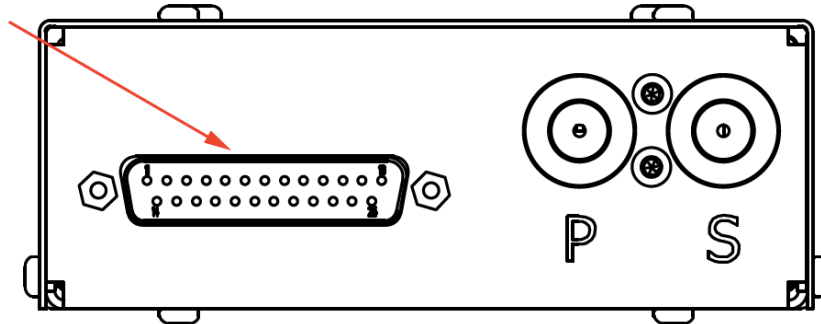

5.4.7. Reconnect aircraft battery.

5.4.8. The unit now should be safely stored until needed for reinstallation.

5.5. Task 05-23-05 – Installation of Vizion Flat (8000-175 / 8000-185)

Installation:

5.5.1. Shut down aircraft power and disconnect the aircraft battery.

5.5.2. Refer to the Autopilot Controller IPC in section 6 of this document for illustrated parts catalog.

5.5.3. Carefully connect the DB25 electrical connector to the back of the unit. Tighten the two retention screws to approximately 12 inch pounds. See Illustration below:

DB 25
connection

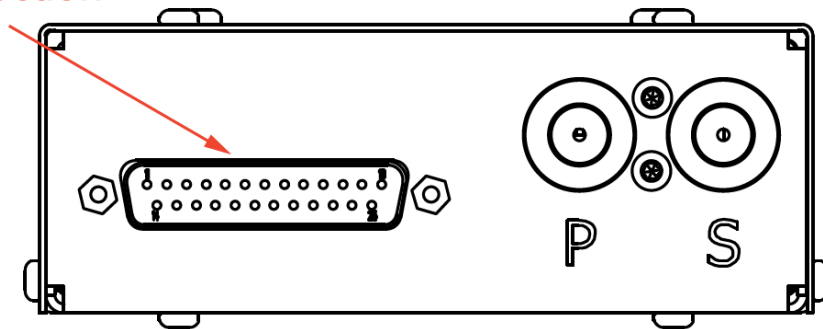

5.5.4. Remove the caps covering the pitot and static ports on the autopilot controller and the caps on the pitot and static lines in the aircraft. Connect the 1/8 NPT pitot line to the 1/8 NPT pitot port and the 1/8 NPT static line to the 1/8 NPT static port. Tighten the pitot and static lines to approximately 12 inch pounds. Illustration below:

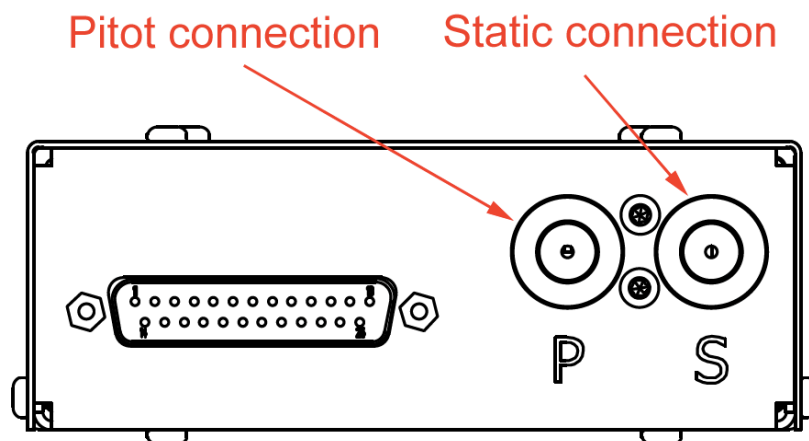

5.5.5. Slide the Vizion autopilot into the instrument panel hole. Depending on location of the Vizion autopilot in the panel, it may be easier to remove the instrument panel rather than reach up behind the panel to install the autopilot.

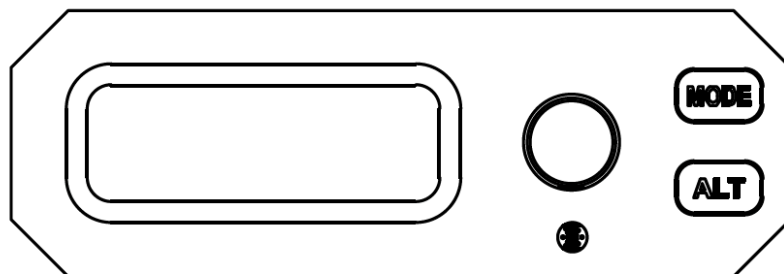

5.5.6. Install the 4 each 6-32 screws holding the autopilot in the panel. Tighten to approximately 12 inch pounds.

5.5.7. Reconnect the aircraft battery and turn on aircraft power.

5.5.8. Configure the unit per the appropriate aircraft model Appendix, Task XX-23-01 (Autopilot Configuration).

5.5.9. If not performed as part of task XX-23-01, perform task 04-24-01 in Section 4 (Operational Check).

5.5.10. Perform and document the Pitot Static System leak check per the appropriate aircraft maintenance manual requirements.

5.6. Task 05-23-06 – Configuration of Vizion Flat (8000-175 / 8000-185)

Configuration:

See appropriate aircraft model Appendix for aircraft specific configuration.

5.7. Task 05-23-07 – Removal of Vizion 3-Inch Round (8000-176 / 8000-184)

Removal:

- 5.7.1. Shut down aircraft power and disconnect the aircraft battery.
- 5.7.2. Refer to the Autopilot Controller IPC in section 6 of this document for illustrated parts catalog.
- 5.7.3. Remove the four (4) 6-32 screws holding the autopilot in the panel.
- 5.7.4. Slide the Vizion autopilot back and out of the instrument panel. Depending on location of the Vizion autopilot in the panel, it may be easier to remove the instrument panel rather than drop the autopilot out from behind the panel.

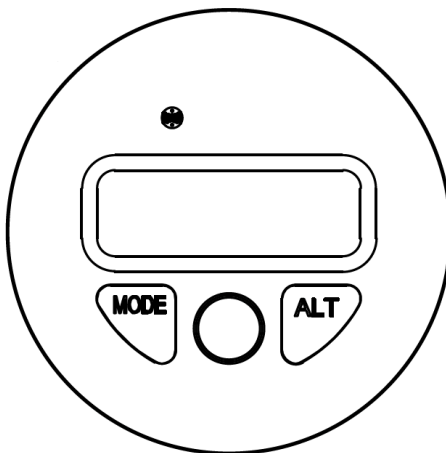

- 5.7.5. Carefully disconnect and cap the 1/8 NPT fittings for the Pitot and Static lines as shown in the figure below. Ensure that both the aircraft pitot and static lines as well as the autopilot pitot and static fittings are capped.

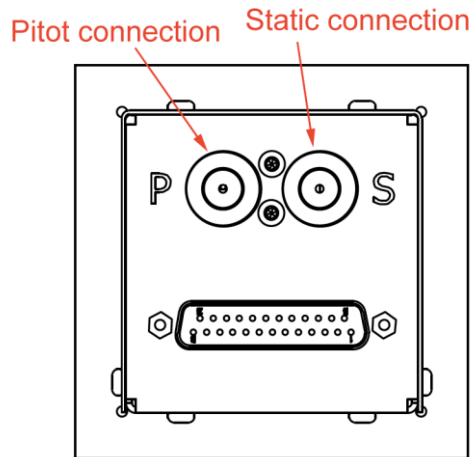

5.7.6. Carefully disconnect the DB25 electrical connector from the back of the unit. This is accomplished by removing the two retention screws and carefully sliding out the connector. See Illustration below:

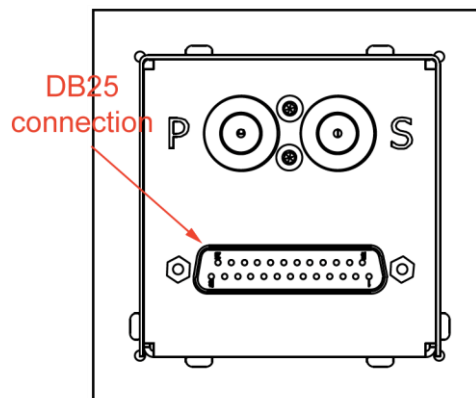

5.7.7.

5.7.8. Reconnect aircraft battery.

5.7.9. The unit now should be safely stored until needed for reinstallation.

5.8. Task 05-23-08 – Installation of Vizion 3-Inch Round (8000-176 / 8000-184)

Installation:

5.8.1. Shut down aircraft power and disconnect the aircraft battery.

5.8.2. Refer to the Autopilot Controller IPC in section 6 of this document for illustrated parts catalog.

5.8.3. Carefully connect the DB25 electrical connector to the back of the unit. Tighten the two retention screws to approximately 12 inch pounds. See Illustration below:

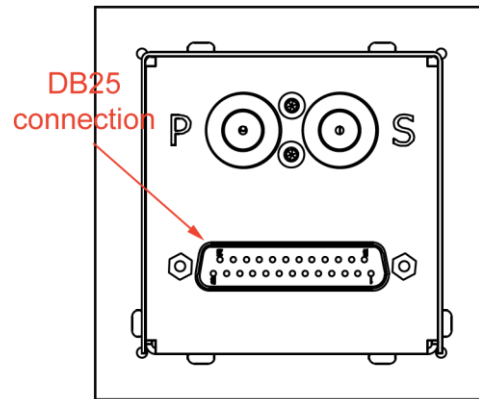

5.8.4. Remove the caps covering the pitot and static ports on the autopilot controller and the caps on the pitot and static lines in the aircraft. Connect the 1/8 NPT pitot line to the 1/8 NPT pitot port and the 1/8 NPT static line to the 1/8 NPT static port. Tighten the pitot and static lines to approximately 12 inch pounds. Illustration below:

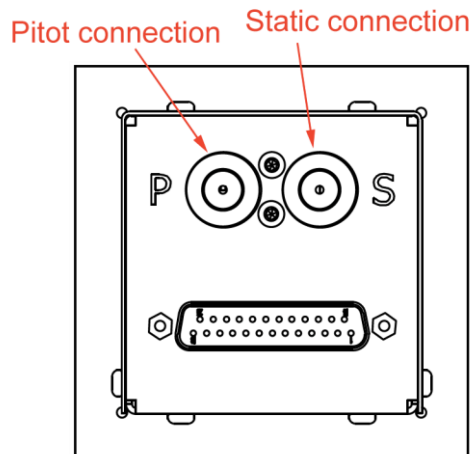

5.8.5. Slide the Vizion autopilot into the instrument panel hole. Depending on location of the Vizion autopilot in the panel, it may be easier to remove the instrument panel rather than reach up behind the panel to install the autopilot.

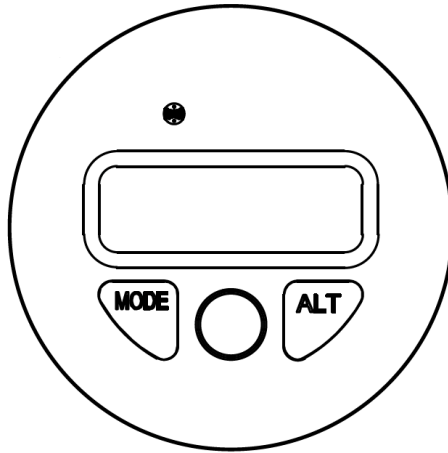

5.8.6. Install the 4 each 6-32 screws holding the autopilot in the panel. Tighten to approximately 12 inch pounds.

5.8.7. Reconnect the aircraft battery and turn on aircraft power.

5.8.8. Configure the unit per the appropriate aircraft model Appendix, Task XX-23-01 (Autopilot Configuration).

5.8.9. If not performed as part of task XX-23-01, perform task 04-24-01 in Section 4 (Operational Check).

5.8.10. Perform and document the Pitot Static System leak check per the appropriate aircraft maintenance manual requirements.

5.9. Task 05-23-09 – Configuration of Vizion 3-Inch Round (8000-176 / 8000-184)

Configuration:

See appropriate aircraft model Appendix for aircraft specific configuration.

5.10. Task 05-23-10 – Removal of CWS Switch

5.10.1. Shut down aircraft power and disconnect the aircraft battery.

5.10.2. Refer to the Vizion Wiring Diagram located in the Vizion PMA Installation Guide (166).

5.10.3. The CWS is a red switch mounted on the pilot yoke. It should be labeled AP DISCO.

- 5.10.4. Because there are so many different styles of yokes and switches possible these instructions will mainly focus on the wiring portion of the CWS switch.
- 5.10.5. Remove the switch from the yoke.
- 5.10.6. Remove the two (2) wires from the switch. It does not matter the location of the two wires.
- 5.10.7. Trace the path of wires back to the main harness. Remove the wires from the control yoke assembly and separately cap each wire.
- 5.10.8. Ensure that neither wire can short to aircraft power, aircraft ground, or to one another.
- 5.10.9. Secure the CWS wires to the main bundle to ensure no interference with the aircraft controls.
- 5.10.10. Reconnect aircraft battery.
- 5.10.11. All parts should now be safely stored until needed for installation.

5.11. Task 05-23-11 – Installation of CWS Switch

- 5.11.1. Shut down aircraft power and disconnect the aircraft battery.
- 5.11.2. Refer to the Vizion Wiring Diagram located in the Vizion PMA Installation Guide (166).
- 5.11.3. Locate the bundled CWS wires in the main autopilot harness.
- 5.11.4. Remove the caps on the two (2) wires.
- 5.11.5. Route the wires out to the pilot control yoke.
- 5.11.6. Connect the wires to the CWS switch. The location of the two wires on the switch does not matter.
- 5.11.7. Mount the CWS switch in the pilot control yoke.
- 5.11.8. Ensure that the switch is properly labeled (AP DISCO).
- 5.11.9. Reconnect aircraft battery.
- 5.11.10. Perform Task 04-24-01 - Operational Check.

6. Autopilot Controller IPC

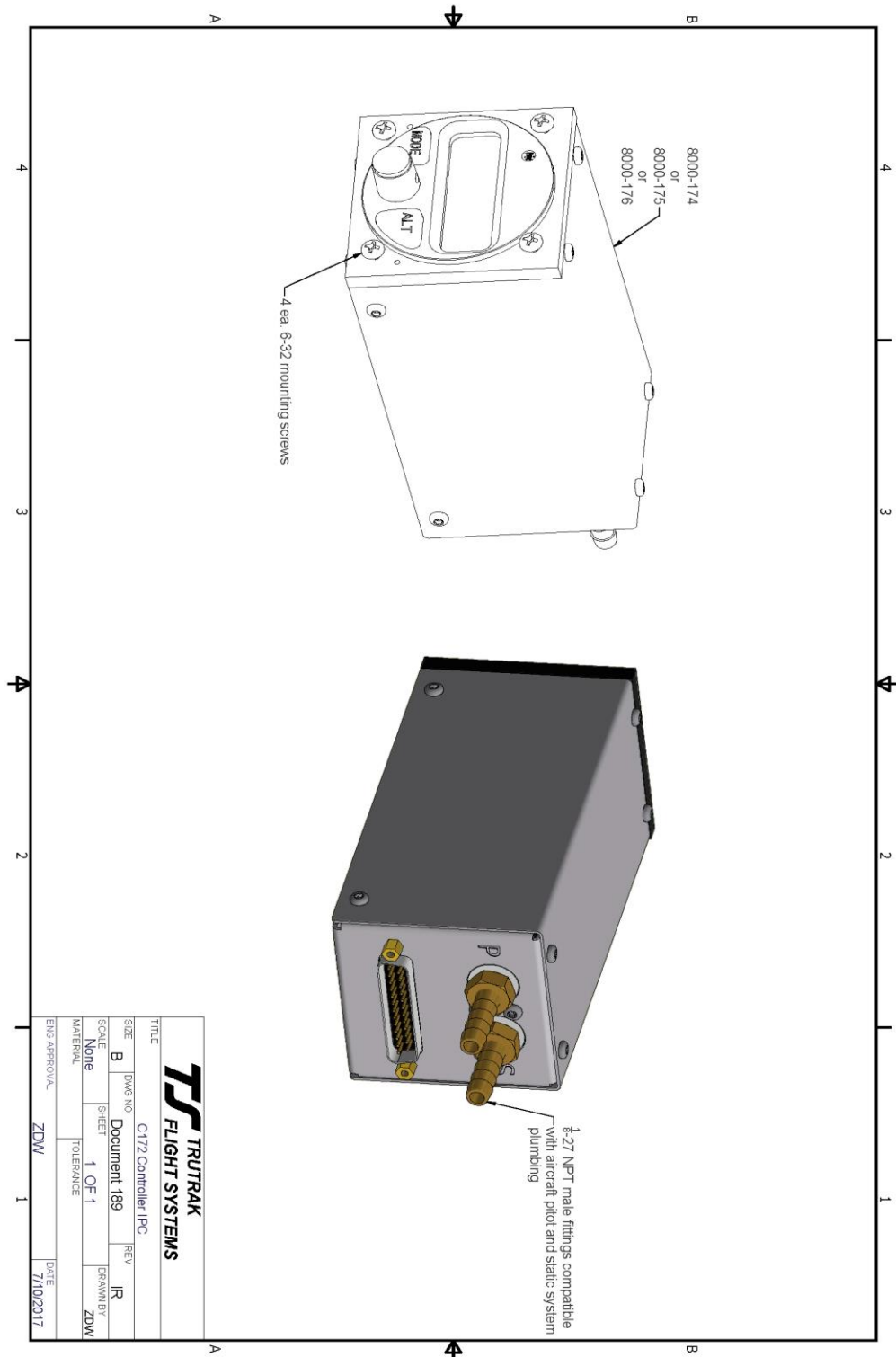

7. Placarding

7.1. Task 07-24-01 – Installation of the autopilot placard

A placard describing the limitations of the Vizion Autopilot must be displayed in prominent view of the pilot to comply with the STC. The placard should be installed in the following manner:

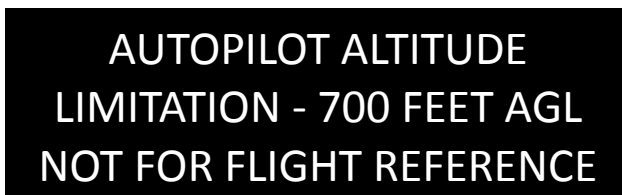

7.1.1. Remove the provided limitations placard, TruTrak Part number 8300-092 (pictured). Placard may have white or clear background with black text, or black background with white text.

7.1.2. Affix the limitations placard to the instrument panel in the approximate location shown below. Though the exact position may vary depending on the aircraft in which the Vizion Autopilot is installed, the placard must be in the pilot's primary field of view.

Approximate location of
Limitations Placard

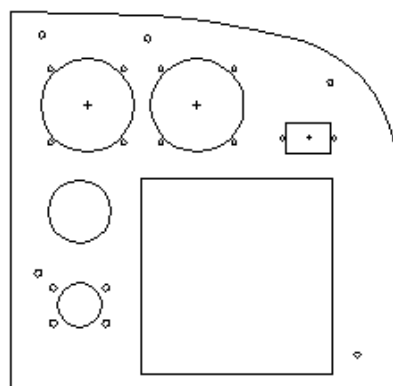
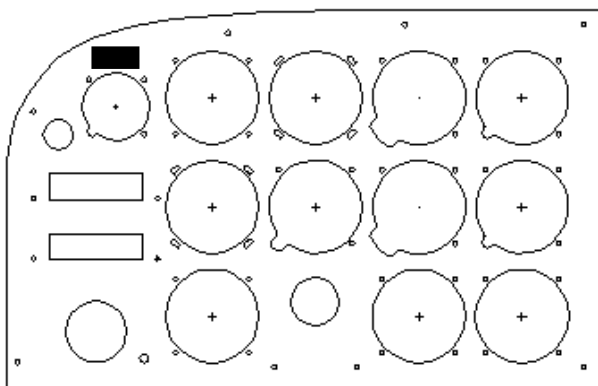

8. Troubleshooting

8.1. Introduction

This section gives the installer or mechanic information pertaining to maintenance of the Vizion Autopilot. Additionally, it provides the steps necessary to ensure continued airworthiness for the unit.

NOTE: Vizion Autopilot contains no user-serviceable parts. Refer all servicing to properly trained and certificated technicians.

Other than for regulatory periodic checks, maintenance of the Vizion Autopilot is “on-condition” only. Periodic maintenance of the Vizion Autopilot is not required.

8.2. Airspeed Check

Perform Task 04-24-04 in Section 4.

8.3. Displayed Alert Messages

The following table describes the alert messages that the Vizion Autopilot can display.

Alert Message	Description	End condition
SENSOR ERROR	This error can occur if a gyro, pressure transducer, or calibration processor fails to respond in a timely manner, or fails completely.	When this error appears, it may be a temporary error, but most likely the autopilot will need to be returned to a certified technician.

8.4. Troubleshooting Guide

The following table provides a list of potential issues that the Vizion Autopilot may experience. The symptom is given on the left side while the probable solution is listed at the right.

Autopilot System Fault	Possible cause	Possible remedy
Autopilot does not power up when circuit breaker / autopilot master is engaged	Circuit breaker malfunction	Inspect and replace circuit breaker if necessary.
	Autopilot not wired to ground	Verify and fix any wiring errors.
Roll servo does not engage when autopilot system is engaged	Roll servo wiring is faulty	Install servo harness tester in place of roll servo, and / or verify correct wiring.
Pitch servo does not engage when autopilot system is engaged	Pitch servo wiring is faulty	Install servo harness tester in place of pitch servo, and / or verify correct wiring.
Roll servo moves in the wrong direction during ground test	Servo wiring incorrect or servo direction not correct in setup.	Verify correct wiring and / or change roll servo direction in autopilot setup.
Pitch servo moves the wrong direction during ground test; trim indicates incorrect direction.	Servo wiring incorrect or servo direction not correct in setup.	Verify correct wiring and / or change pitch servo direction in autopilot setup.
Pitch servo moves the wrong direction during ground test; trim indicates correct direction.	Servo wiring incorrect.	Verify correct wiring
Autopilot controller displays NO GPS	GPS is not configured correctly	Configure RS232 output on GPS.

	Autopilot controller baud rate is set incorrectly	Enter lateral setup menu of autopilot controller, set baud rate to match that of GPS
	GPS wiring is faulty	Check continuity of RS232 transmit wire from GPS to pin 17 of autopilot controller

9. AML STC SA04231CH

United States of America
Department of Transportation -- Federal Aviation Administration
Supplemental Type Certificate

Number SA04231CH

This certificate issued to TruTrak Flight Systems, Inc.
1488 S. Old Missouri Rd.
Springdale, AR 72764

certifies that the change in the type design for the following product with the limitations and conditions therefor as specified herein meets the airworthiness requirements of the Federal Aviation Regulations as denoted on T.O. A. Approved Models List SA04231CH certification basis.

Original Product Type Certificate Number

Make : * (see attached FAA Approved Model List (AML))

Model : No. SA04231CH for the list of

approved models and applicable airworthiness regulations)

Description of Type Design Change:

Installation and activation of a TruTrak Vizion autopilot system, per FAA Approved TruTrak Master Document List, Document Number 195, Revision IR, dated 7-13-2017 (or later FAA approved revision) and installation instructions listed on FAA Approved Models List number SA04231CH.

Limitations and Conditions:

1. Compliance has been established to the regulations listed in AML SA04231CH. This approval should not be extended to aircraft with a regulatory basis differing from that listed in AML SA04231CH without written permission from the Certificate Management Aircraft Certification Office.
2. The autopilot may only be interfaced with external Global Positioning System devices listed in TruTrak Document number 186, Revision Initial, dated 7/5/2017 or later FAA approved revision.
3. Installation of the autopilot requires that a quick release (emergency) control must be located on the control wheel on the side opposite the throttles, or on the stick control, such that it can be operated without moving the hand from its normal position on the associated control.
4. Compatibility of the design change with previously approved modifications must be determined by the installer.
5. If the holder agrees to permit another person to use this certificate to alter the product, the holder shall give the other person written evidence of that permission.

...End...

This certificate and the supporting data, which is the basis for approval, shall remain in effect until surrendered, suspended, revoked or a termination date is otherwise established by the Administrator of the Federal Aviation Administration.

Date of application: July 11, 2017

Date reissued: March 13, 2019

Date of issuance: July 19, 2017

Date amended:



By direction of the Administrator



Timothy P. Smyth (Signature)
Manager
Chicago ACO Branch

(Title)

Any alteration of this certificate is punishable by a fine of not exceeding \$1,000, or imprisonment not exceeding 3 years, or both.
FAA FORM 8110-2(10-68) PAGE 1 of 2 PAGES This certificate may be transferred in accordance with FAR 21.47.

10. Appendix A – Cessna 172 F - S Models

10.1. Cessna 172 F – S Additional Installation Components

1450-107	Cessna 172 Upper Roll Bracket
1450-108	Cessna 172 Lower Roll Bracket
7200-088	Cessna 172 Roll Inboard Pushrod
7200-090	Cessna 172 Roll Outboard Pushrod
7200-091	Cessna 172 Roll Servo Arm
1450-109	Cessna 172 Late Model Pitch Bracket
1450-110	Cessna 172 Late Model Pitch Servo Stop
1420-208	Cessna 172 Late Model Pitch Clamp Half (2 required)
1420-209	Cessna 172 Late Model Pitch Servo Arm

10.2. Cessna 172 F - S Equipment Locations

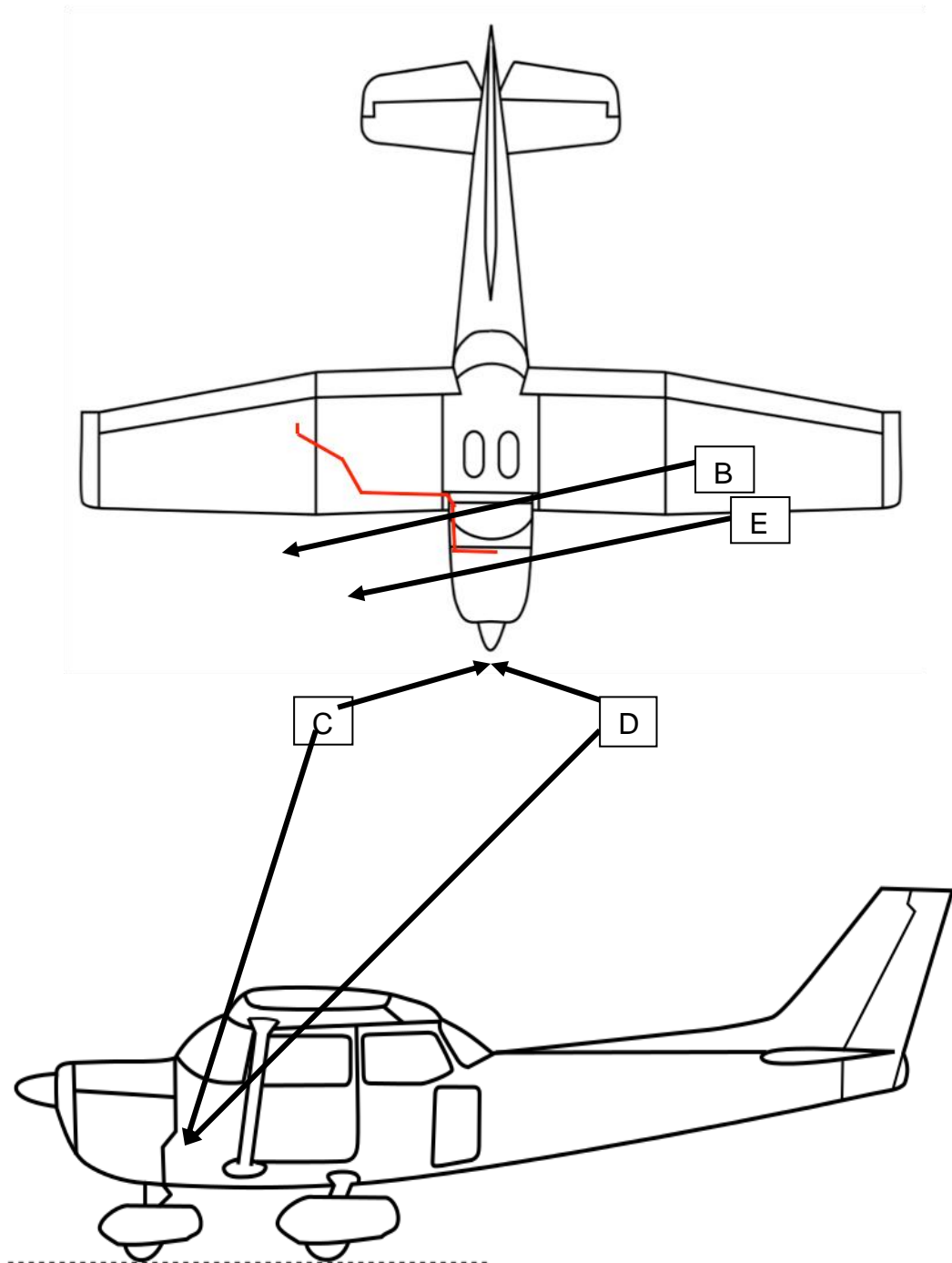

The above locations are general guidance. Actual equipment locations may vary per aircraft.

Wiring harness routing: The roll harness routing is shown by line E. This portion passes to right side of the aircraft and up into the right wing following the main wiring bundle up the side of the aircraft and through the wing. The pitch harness is a very short run and routing may be determined by the installer, as long as it is secured to the left side of the pitch servo mounting bracket, as instructed in Task 10-23-05.

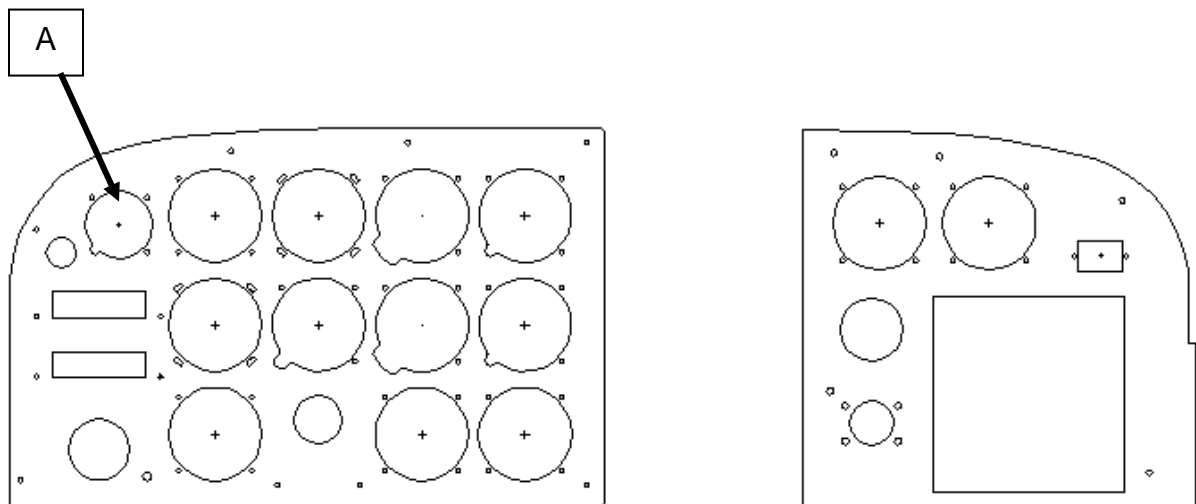

LRU Definitions

A	Vizion Autopilot
B	12 Volt Roll Servo (8100-064) OR 24 Volt Roll Servo (8100-065)
C	12 Volt Pitch Servo (8100-064) OR 24 Volt Pitch Servo (8100-065)

D	Link Sensor (8000-177)
E	Roll Servo Wiring Harness Location

10.3. Task 10-23-01 – Cessna 172 F – S Autopilot Configuration

10.3.1. If your unit is being reinstalled into the aircraft it was removed from, and no corrective action has been performed on the unit, no further configuration is necessary. Operation check the unit per Task 04-24-01 in Section 4.

10.3.2. If the unit was not previously installed in the aircraft, or has been serviced, perform the following steps:

Configure Autopilot

The Vizion autopilot has the adjustable gain settings to fly nearly any aircraft in which it may be installed, therefore it is imperative that it be configured to properly fly the aircraft. Refer to the Vizion PMA Installation Guide – C172 Appendix A (listed under reference documentation in section 1.2 of this document) for configuration settings and procedures.

10.4. Task 10-23-02 – Removal of Cessna 172 F – S Roll Servo

10.4.1. Shut down aircraft power and disconnect the aircraft battery.

10.4.2. Refer to the Cessna 172 F – S Vizion Roll IPC in Section 10.15 of this document for illustrated parts catalog.

10.4.3. The roll servo (8100-064 or 8100-065) is located in the right wing just forward of the inboard end of the right aileron.

10.4.4. Remove the inspection cover on the lower right wing skin located forward of the inboard end of the right aileron.

10.4.5. Remove the AN3-7A bolt holding the pushrod to the roll servo arm.

10.4.6. Remove the four (4) AN3-3A bolts and four (4) MS35333-39 lock washers holding the roll servo (8100-064) to the roll servo bracket.

10.4.7. Remove the electrical connector from the back of the servo.

10.4.8. Remove the servo through the inspection hole.

10.4.9. If the roll servo is being replaced immediately, proceed to step three (3) of the roll servo installation instructions.

If the servo is being removed for repair or service, the pushrod must also be removed using the following steps.

10.4.10. Remove the inspection cover on the lower right wing skin located forward of the outboard end of the right aileron.

- 10.4.11. Loosen the jam nut on the end of the roll pushrod.
- 10.4.12. Unscrew the pushrod from the rod end bearing.
- 10.4.13. Remove the AN3-16A bolt, AN970-3 washer, MM-3-300 rod end bearing, and the two (2) AN960-10 washers.
- 10.4.14. Replace the AN3-16A bolt with an appropriate length AN3 bolt.
- 10.4.15. Working through the already open inboard inspection hole, disassemble the pushrod (it is a two-part assembly) by removing the two (2) AN3-7A bolts and MS20364-1032 nuts.
- 10.4.16. Remove both sections of pushrod through the inspection hole.
- 10.4.17. Verify that the wiring harness is properly secured and will not interfere with the aircraft control cables.
- 10.4.18. Reinstall both inspection covers.
- 10.4.19. Reconnect aircraft battery.
- 10.4.20. All parts should now be safely stored until needed for installation.

10.5. Task 10-23-03 – Installation of Cessna 172 F – S Roll Servo

- 10.5.1. Shut down aircraft power and disconnect the aircraft battery.
- 10.5.2. Refer to the Cessna 172 F – S Vizion Roll IPC in Section 10.15 of this document for illustrated parts catalog.
- 10.5.3. Remove the inspection cover on the lower right wing skin located forward of the outboard end of the right aileron.
- 10.5.4. Remove the inspection cover on the lower right wing skin located forward of the inboard end of the right aileron.
- 10.5.5. Ensure that wiring harness is free to connect to servo at inboard inspection hole.
- 10.5.6. Insert roll servo through inboard inspection hole.
- 10.5.7. Install roll servo 9 pin connector from wiring harness to roll servo. Tighten two retention screws to approximately 2-3 inch pounds. Ensure that wiring harness will not be wrapped around any aircraft cables or the roll servo pushrod.
- 10.5.8. Place roll servo in roll servo mounting bracket. Ensure that the servo arm fits between the servo stops built into the roll servo bracket. See the figure below for proper roll servo / roll servo mounting bracket configuration:

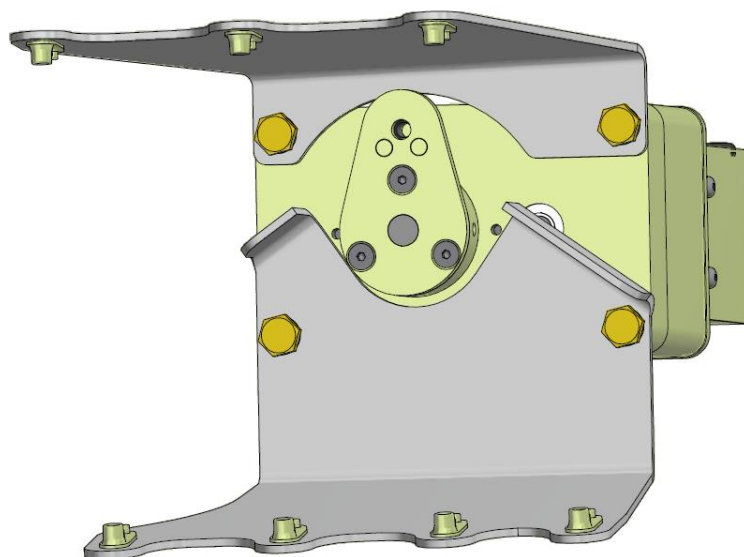

10.5.9. Attach roll servo to roll servo bracket using four (4) AN3-3A bolts and four (4) MS35333-39 lock washers. Prior to installation of the four (4) bolts, apply Loctite 242 or equivalent thread locker to the bolts. Tighten the bolts to 20-25 inch pounds.

10.5.10. If the roll servo pushrod is still in the aircraft because the roll servo is being immediately replaced after removal, proceed to step 16. Otherwise, proceed to step 11.

10.5.11. Insert both sections of the roll servo pushrod through the inboard inspection hole. The inboard portion of the pushrod contains two aluminum inserts and should still contain one rod end bearing, and the outboard contains only one aluminum insert.

10.5.12. Assemble the pushrod using two (2) AN3-7A bolts and two (2) MS20364-1032 nuts. The threaded portion of the inboard pushrod half (the end with a rod end bearing still installed) goes toward the servo. The threaded portion of the outboard portion of the pushrod half goes toward the bellcrank. Torque the bolts to 20-25 inch pounds.

10.5.13. Attach the assembled pushrod to the bellcrank. Remove the rear aileron bellcrank cable attachment bolt and replace with one (1) AN3-16A, one (1) AN970-3, one (1) MM-3-300, and two (2) AN960-10. Torque the bolt to 20-25 inch pounds.

10.5.14. Thread one (1) AN345-10 nut all the way onto the MM-3-300 rod end bearing.

10.5.15. Thread the pushrod assembly onto the MM-3-300 rod end bearing (the final length of the pushrod will be adjusted in the next step).

10.5.16. Temporarily attach the pushrod to the roll servo arm using one (1) AN3-7A, one (1) AN970-3, and two (2) AN960-10. Do not torque the bolt yet!

10.5.17. Check the full left and right control deflections. Ensure that full aileron travel is possible without the servo arm contacting the servo stops built into the roll servo bracket. If full travel is not possible, remove the bolt in step 16 and adjust the length of the pushrod by adjusting the rod ends at one or both ends of the pushrod.

10.5.18. Once full control travel is verified, torque the jam nuts at both ends of the pushrod to 20-25 inch pounds as well as the bolt connecting the roll servo pushrod to the roll servo arm.

10.5.19. Verify that the wiring harness is properly secured and will not interfere with the aircraft control cables.

10.5.20. Reinstall both inspection covers.

10.5.21. Reconnect aircraft battery.

10.5.22. Perform Task 04-24-01 and Task 04-24-05.

10.6. Task 10-23-04 – Removal of Cessna 172 F – S Pitch Servo

10.6.1. Shut down aircraft power and disconnect the aircraft battery.

10.6.2. Refer to the Cessna 172 F – S Vizion Pitch IPC in Section 10.16 of this document for illustrated parts catalog.

10.6.3. The pitch servo (8100-064 or 8100-065) is located forward of the lower portion of the instrument panel, down between the pilot and co-pilot rudder pedals.

10.6.4. Remove the pitch clamp cross bolt (AN3-22A) from the control yoke assembly.

10.6.5. Remove the fore and aft pitch clamp bolts (AN3-11A) from the pitch clamp.

10.6.6. Remove the pitch clamp halves from the control yoke.

10.6.7. Remove the pitch pushrod bolt (AN3-11A) and three (3) AN960-10 washers from the pitch servo arm.

10.6.8. Disconnect 6 pin connector from link sensor.

10.6.9. Ensure that 6 pin connector / harness is adequately secured and will not interfere with aircraft controls.

10.6.10. Remove the Link Sensor (8000-177).

10.6.11. Remove the six (6) AN3-3A bolts and six (6) MS35333-39 lock washers holding the pitch servo bracket to the mounting flanges on the center tunnel.

10.6.12. Remove the electrical connector from the back of the pitch servo.

10.6.13. Remove the four (4) AN3-3A bolts and four (4) MS35333-39 lock washers holding the pitch servo (8100-064) to the pitch servo bracket. Note the location of the pitch servo stop and arm for future assembly.

10.6.14. Remove pitch servo wiring harness from pitch servo bracket.

10.6.15. Remove 6 pin link sensor connector / harness from pitch servo.

10.6.16. Remove pitch servo and bracket.

10.6.17. Ensure that pitch servo wiring harness is adequately secured and will not interfere with aircraft controls.

10.6.18. Reconnect aircraft battery.

10.6.19. All parts should now be safely stored until needed for installation.

10.7. Task 10-23-05 – Installation of Cessna 172 F – S Pitch Servo

10.7.1. Shut down aircraft power and disconnect the aircraft battery.

10.7.2. Refer to the Cessna 172 F – S Vizion Pitch IPC in Section 10.16 of this document for illustrated parts catalog.

10.7.3. Attach pitch servo to pitch servo bracket using four (4) AN3-3A bolts, and four (4) MS35333-39 lock washers. Ensure that the pitch servo stop is properly placed on the pitch servo / bracket assembly before installing bolts. Prior to installation of the four (4) bolts, apply Loctite 242 or equivalent thread locker to the bolts. Tighten the bolts to 20-25 inch pounds. The figure below shows the proper pitch servo, pitch servo stop, and pitch servo mount bracket configuration:

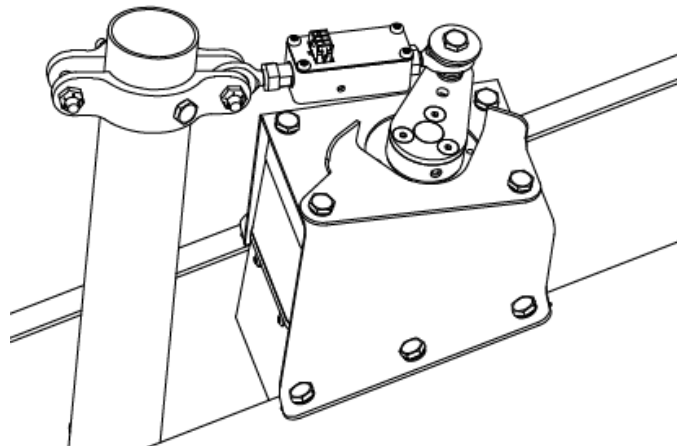

10.7.4. Install pitch servo 9 pin connector from wiring harness to pitch servo. Tighten two retention screws to approximately 2-3 inch pounds.

10.7.5. Attach the 6 pin link sensor connector to the pitch servo.

10.7.6. Install mounting bracket / servo assembly using six (6) AN3-3A bolts and six (6) MS35333-39 lock washers. Torque the bolts to 20-25 inch pounds.

10.7.7. Attach the pitch servo wiring harness to the left side of the pitch servo bracket using cable ties or lacing cord.

10.7.8. Install the pitch clamp using two (2) pitch clamp parts (TT p/n1420-208), two (2) AN3-11A, the link sensor, one (1) AN3-22A, one (1) AN960-10, and three (3) MS20364-1032, Torque all three bolts to 20-25 inch pounds.

Follow the illustration below:

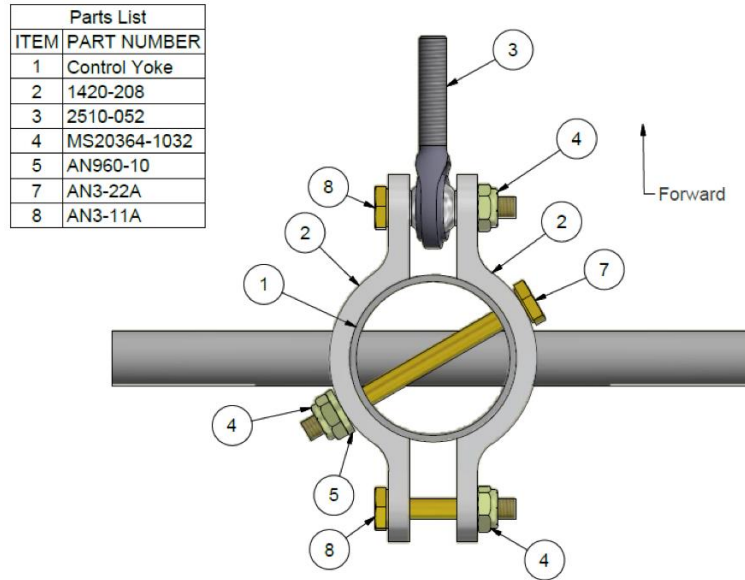

10.7.9. Connect the link sensor to the pitch servo arm using one (1) AN3-11A bolt, one (1) AN970-3, three (3) AN960-10 and one (1) MS20364-1032. Refer to Appendix E for assembly diagram. Torque bolt to 20-25 inch pounds.

10.7.10. Attach the 6 pin link sensor connector to the link sensor.

10.7.11. Ensure the link sensor cable is properly secured.

10.7.12. Reconnect aircraft battery.

10.7.13. Perform Task 04-24-01 and Task 04-24-06.

10.8. Task 10-23-06 – Removal of Cessna 172 F – S Link Sensor

10.8.1. Shut down aircraft power and disconnect the aircraft battery.

10.8.2. Refer to the Cessna 172 F – S Vizion Pitch IPC in Section 10.16 of this document for illustrated parts catalog.

10.8.3. The pitch servo is located forward of the lower portion of the instrument panel, down between the pilot and co-pilot rudder pedals.

10.8.4. Disconnect 6 pin connector from link sensor.

- 10.8.5. Remove the pitch clamp cross bolt (AN3-22A) from the control yoke assembly.
- 10.8.6. Remove the fore and aft pitch clamp bolts (AN3-11A) from the pitch clamp.
- 10.8.7. Remove the pitch clamp halves from the control yoke.
- 10.8.8. Remove the pitch pushrod bolt (AN3-10A) from the pitch servo arm.
- 10.8.9. Remove the Link Sensor (8000-177).
- 10.8.10. Ensure that 6 pin connector / harness is adequately secured and will not interfere with aircraft controls.
- 10.8.11. Reconnect aircraft battery.
- 10.8.12. All parts should now be safely stored until needed for installation.

10.9. Task 10-23-07 – Installation of Cessna 172 F – S Link Sensor

- 10.9.1. Shut down aircraft power and disconnect the aircraft battery.
- 10.9.2. Refer to the Cessna 172 F – S Vizion Pitch IPC in Section 10.16 of this document for illustrated parts catalog.
- 10.9.3. Install the pitch clamp using two (2) pitch clamp parts (TT p/n1420-208), two (2) AN3-11A, the link sensor, one (1) AN3-22A, one (1) AN960-10, and three (3) MS20364-1032, Torque all three bolts to 20-25 inch pounds. Follow the illustration below:

Parts List	
ITEM	PART NUMBER
1	Control Yoke
2	1420-208
3	2510-052
4	MS20364-1032
5	AN960-10
7	AN3-22A
8	AN3-11A

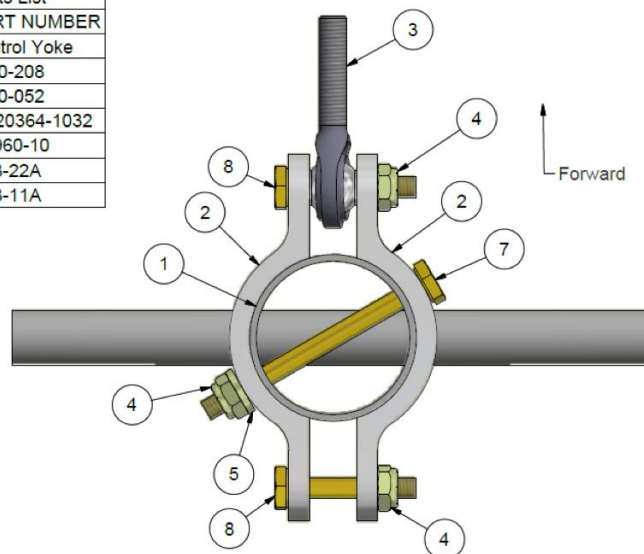

10.9.4.

- 10.9.5. Connect the link sensor to the pitch servo arm using one (1) AN3-11A bolt, one (1) AN970-3, three (3) AN960-10 and one (1) MS20364-1032. Refer to Appendix E for assembly diagram. Torque bolt to 20-25 inch pounds.

- 10.9.6. Attach the 6 pin link sensor connector to the link sensor.
- 10.9.7. Ensure the link sensor cable is properly secured.
- 10.9.8. Reconnect aircraft battery.
- 10.9.9. Perform Task 04-24-01, Task 04-24-06, and Task 04-24-07.

11. Appendix B – Cessna 177 Models

11.1. Cessna 177 Additional Installation Components

- 11.1.1. 7200-093 Cessna 177 Roll Bracket Assembly
- 11.1.2. 1450-112 Cessna 177 Pitch Plate
- 11.1.3. 7200-092 Cessna 177 Pitch Bracket Assembly
- 11.1.4. 7200-096 2.5" Servo Arm
- 11.1.5. 7200-091 Cessna 172 Roll Servo Arm
- 11.1.6. 2520-021 17" ¼-28 Pushrod
- 11.1.7. 2520-046 5" ¼-28 Pushrod
- 11.1.8. 2520-024 5.5" 10-32 Pushrod

11.2. Cessna 177 Equipment Locations

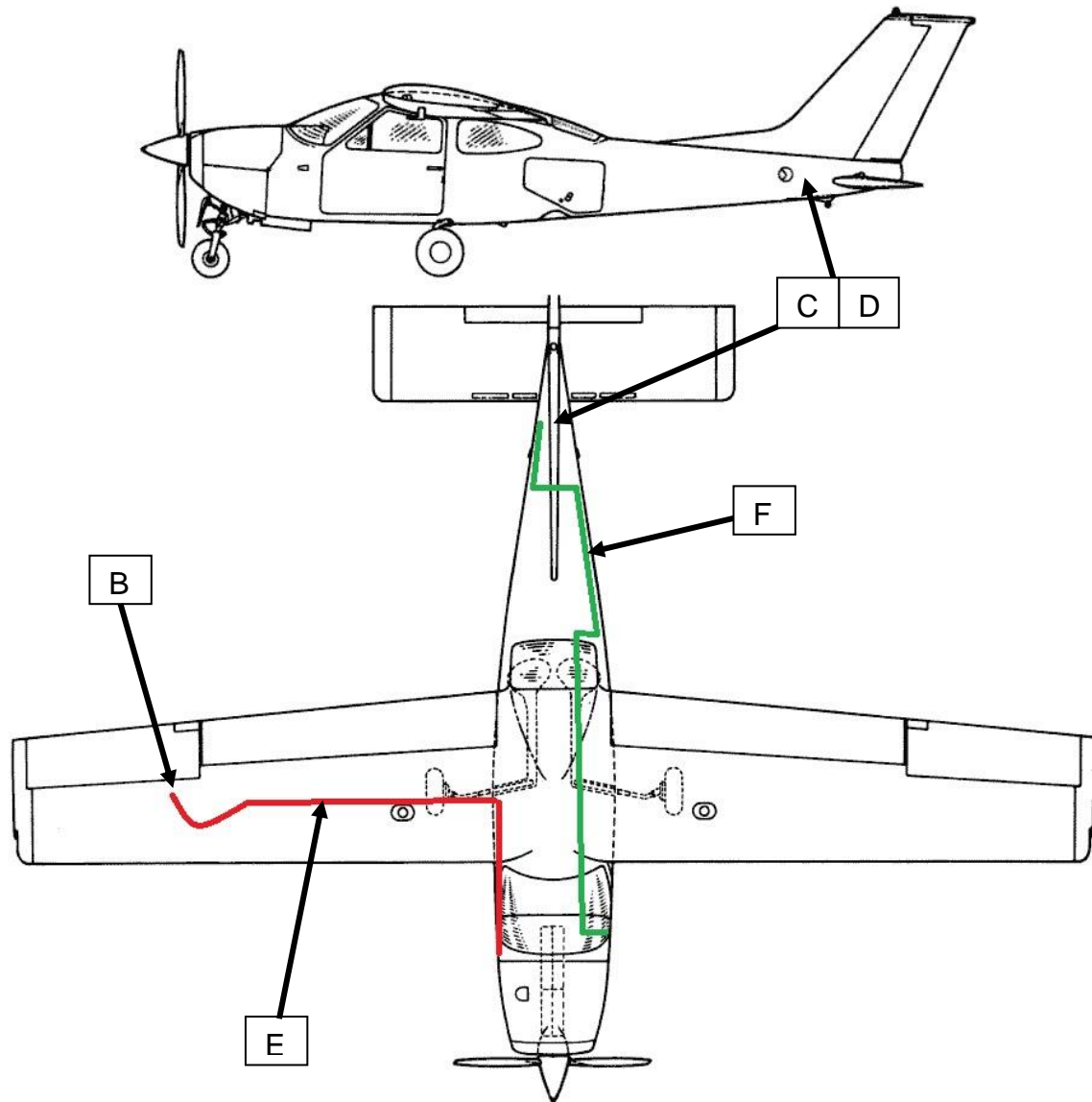

The above locations are general guidance. Actual equipment locations may vary per aircraft.

Wiring harness routing: The roll harness routing is shown by line E. This portion passes to right side of the aircraft and up into the right wing following the main wiring bundle up the side of the aircraft and through the wing. The roll harness routing is shown by line F. This portion passes from the panel down the left kick panel, under the cabin floor, down the left side of the aft fuselage then crosses to the right side of the aircraft connecting to the pitch servo.

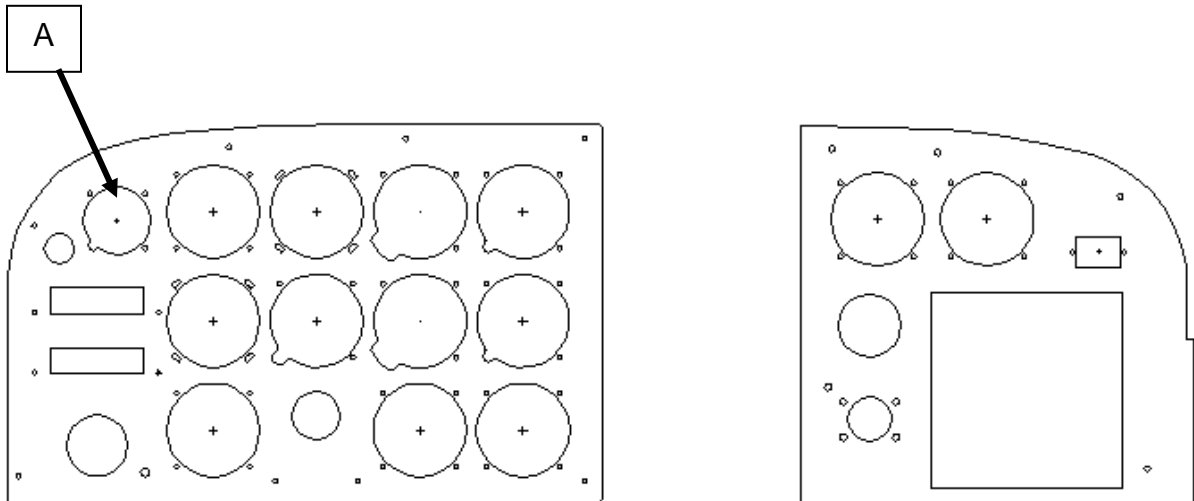

LRU Definitions

A	Vizion Autopilot
B	12 Volt Roll Servo (8100-064) OR 24 Volt Roll Servo (8100-065)
C	12 Volt Pitch Servo (8100-064) OR 24 Volt Pitch Servo (8100-065)
D	Link Sensor (8000-177)
E	Roll Servo Wiring Harness Location
F	Pitch Servo Wiring Harness Location

11.3. Task 11-23-01 – Cessna 177 Autopilot Configuration

11.3.1. If your unit is being reinstalled into the aircraft it was removed from, and no corrective action has been performed on the unit, no further configuration is necessary. Operation check the unit per Task 04-24-01 in Section 4.

11.3.2. If the unit was not previously installed in the aircraft, or has been serviced, perform the following steps:

Configure Vizion Autopilot

The Vizion autopilot has the adjustable gain settings to fly nearly any aircraft in which it may be installed, therefore it is imperative that it be configured to properly fly the Cessna 177 aircraft. Refer to the Vizion PMA Installation Guide – C177 Appendix B (listed under reference documentation in section 1.2 of this document) for configuration settings and procedures.

11.4. Task 11-23-02 – Removal of Cessna 177 Roll Servo

- 11.4.1. Shut down aircraft power and disconnect the aircraft battery.
- 11.4.2. Refer to the Cessna 177 Vizion Roll IPC in Section 11.15 of this document for illustrated parts catalog.
- 11.4.3. The roll servo (8100-064 or 8100-065) is located in the right wing just forward of the inboard end of the right aileron.
- 11.4.4. Remove the inspection cover on the lower right wing skin located forward of the inboard end of the right aileron.
- 11.4.5. Remove the AN3-11A bolt, three (3) AN960-10 washers, and AN970-10 washer holding the pushrod to the roll servo arm.
- 11.4.6. Remove the three (3) AN3-3A bolts and three (3) MS35333-39 lock washers holding the roll servo (8100-064 or 8100-065) to the roll servo bracket.
- 11.4.7. Remove the electrical connector from the back of the servo.
- 11.4.8. Remove the servo through the inspection hole.
- 11.4.9. If the roll servo is being replaced immediately, proceed to step four (4) of the roll servo installation instructions. If the servo is being removed for repair or service, the pushrod must also be removed using the following steps.
- 11.4.10. Remove the AN3-13A bolt, AN970-3 washer, pushrod assembly, AN960-416 washer, AN960-416L washer, and 2510-073 aluminum spacer from the aileron bellcrank.
- 11.4.11. Replace the AN3-13A bolt with an appropriate length AN3 bolt and nut. The 2510-202 steel spacer must remain in place inside the cable clevis. Torque to 20-25 inch pounds.
- 11.4.12. Verify that the wiring harness is properly secured and will not interfere with the aircraft control cables.
- 11.4.13. Reinstall inspection cover.
- 11.4.14. Reconnect aircraft battery.
- 11.4.15. All parts should now be safely stored until needed for installation.

11.5. Task 11-23-03 – Installation of Cessna 177 Roll Servo

- 11.5.1. Shut down aircraft power and disconnect the aircraft battery.
- 11.5.2. Refer to the Cessna 177 Vizion Roll IPC in Section 11.15 of this document for illustrated parts catalog.
- 11.5.3. Remove the inspection cover on the lower right wing skin located forward of the inboard end of the right aileron.

11.5.4. Insert roll servo through the inspection hole. Ensure that wiring harness is free to connect to servo at inboard inspection hole.

11.5.5. Install roll servo 9 pin connector from wiring harness to roll servo. Tighten two retention screws to approximately 2-3 inch pounds. Ensure that wiring harness will not be wrapped around any aircraft cables or the roll servo pushrod.

11.5.6. Place roll servo in roll servo mounting bracket. Ensure that the servo arm fits between the servo stops built into the roll servo bracket. See the figure below for proper roll servo / roll servo mounting bracket configuration:

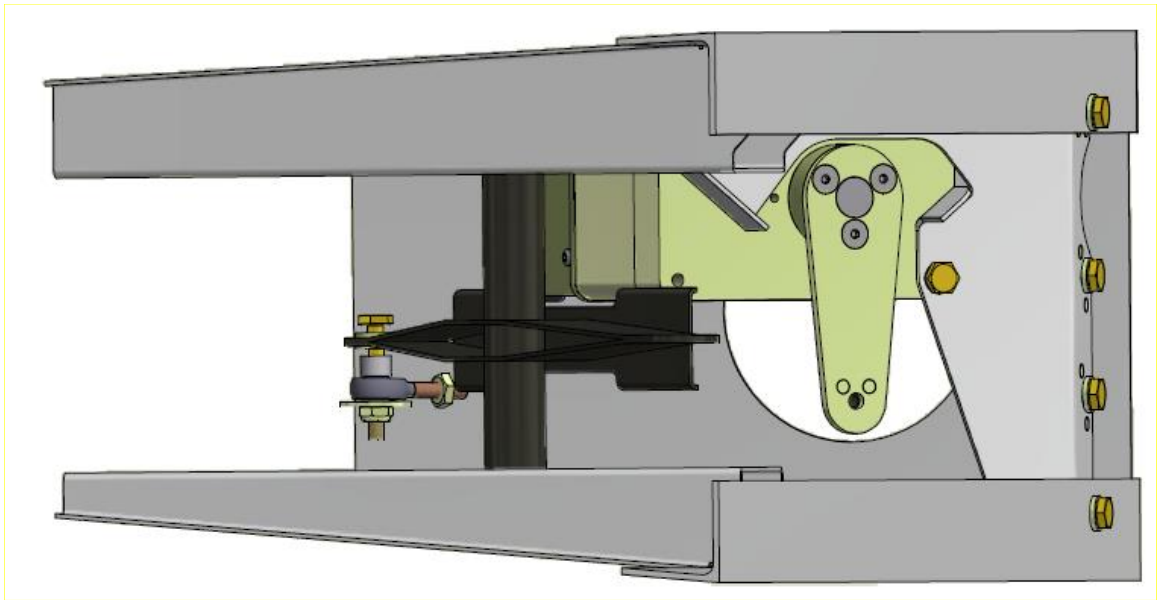

11.5.7. Attach roll servo to roll servo bracket using three (3) AN3-3A bolts and three (3) MS35333-39 lock washers. Prior to installation of the three (3) bolts, apply Loctite 242 or equivalent thread locker to the bolts. Tighten the bolts to 20-25 inch pounds.

11.5.8. If the roll servo pushrod is still in the aircraft because the roll servo is being immediately replaced after removal, proceed to step 11. Otherwise, proceed to step 9.

11.5.9. Remove the AN3 bolt connecting the cable clevis to the aileron bellcrank.

11.5.10. Reconnect the cable clevis to the aileron bellcrank using hardware as shown below. Torque AN3-13A bolt to 20-25 inch pounds. The pushrod assembly will still be connected to the MM-3-300 rod end bearing.

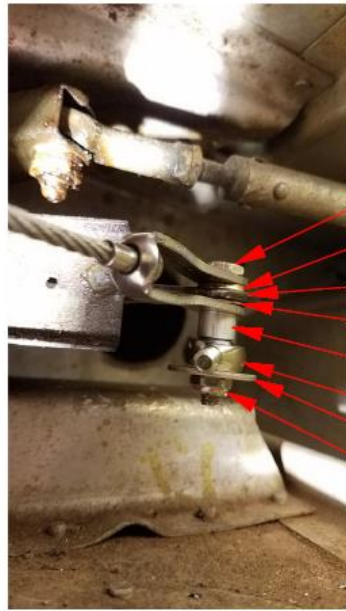

- AN3-13A
- AN960-416
- 2510-202 Thru Bellcrank
- AN960-416L
- 2510-073
- MM-3-300 Rod End Bearing
- AN970-3
- MS20364-1032

11.5.11. Temporarily attach the pushrod to the roll servo arm as shown below. Do not torque the bolt yet!



- AN970-3
- AN3-11A
- 2X AN960-10
- AN960-10
- CM-3B-14 Rod End Bearing

11.5.12. Check the full left and right control deflections. Ensure that full aileron travel is possible without the servo arm contacting the servo stops built into the roll servo bracket. If full travel is not possible, remove the bolt in step 11 and adjust the length of the pushrod by adjusting the rod ends at one or both ends of the pushrod.

11.5.13. Once full control travel is verified, torque the jam nuts at both ends of the pushrod to 20-25 inch pounds as well as the AN3-11A bolt connecting the roll servo pushrod to the roll servo arm.

11.5.14. Verify that the wiring harness is properly secured and will not interfere with the aircraft control cables.

11.5.15. Reinstall inspection cover.

11.5.16. Reconnect aircraft battery.

11.5.17. Perform Task 04-24-01 and Task 04-24-05.

11.6. Task 11-23-04 – Removal of Cessna 177 Pitch Servo

11.6.1. Shut down aircraft power and disconnect the aircraft battery.

11.6.2. Refer to the Cessna 177 Vizion Pitch IPC in Section 11.16 of this document for illustrated parts catalog.

11.6.3. The pitch servo (8100-064 or 8100-065) is located in the aft portion of the fuselage at station 263.0.

11.6.4. Remove the inspections covers forward and aft of station 263.0 on both sides of the aircraft.

11.6.5. Remove the baggage compartment bulkhead.

11.6.6. Disconnect the pitch pushrod by removing the AN3-10A pitch pushrod bolt, two (2) AN960-10 washers, and AN970-3 washer from the pitch servo arm.

11.6.7. Remove the four (4) AN3-3A bolts and four (4) MS35333-39 lock washers holding the pitch servo (8100-064 or 8100-065) to the pitch servo bracket. Note the location of the pitch servo arm between the servo stops for future assembly.

11.6.8. Remove the electrical connector from the back of the pitch servo.

11.6.9. Remove 6 pin link sensor connector / harness from pitch servo.

11.6.10. Remove pitch servo.

11.6.11. If the pitch servo is being replaced immediately, proceed to step eight (8) of the pitch servo installation instructions. If the servo is being removed for repair or service, the pushrod assembly must also be removed using the following steps.

11.6.12. Remove the tailcone to expose the upper center portion of the stabilator.

11.6.13. Disconnect the 6 pin sensor connector / harness from link sensor.

11.6.14. Remove the AN3-7A bolt, two (2) AN960-10 washers, and AN970-3 washer to disconnect the pitch push rod assembly from the pitch arm on the stabilator.

11.6.15. Remove the pitch push rod assembly

11.6.16. Ensure that pitch servo wiring harness and both ends of the 6 pin wiring harness are adequately secured and will not interfere with aircraft controls.

11.6.17. Replace the tailcone removed in step 12.

11.6.18. Replace inspections covers removed in step 4.

11.6.19. Replace baggage compartment bulkhead removed in step 5.

11.6.20. Reconnect aircraft battery.

11.6.21. All parts should now be safely stored until needed for installation.

11.7. Task 11-23-05 – Installation of Cessna 177 Pitch Servo

11.7.1. Shut down aircraft power and disconnect the aircraft battery.

11.7.2. Refer to the Cessna 177 Vizion Pitch IPC in Section 11.16 of this document for illustrated parts catalog.

11.7.3. Remove the inspections covers forward and aft of station 263.0 on both sides of the aircraft.

11.7.4. Remove the baggage compartment bulkhead.

11.7.5. Remove the tailcone to expose the upper center portion of the stabilator.

11.7.6. Connect the pitch push rod assembly to the pitch arm on the stabilator as shown below. Torque to 20-25 inch pounds.

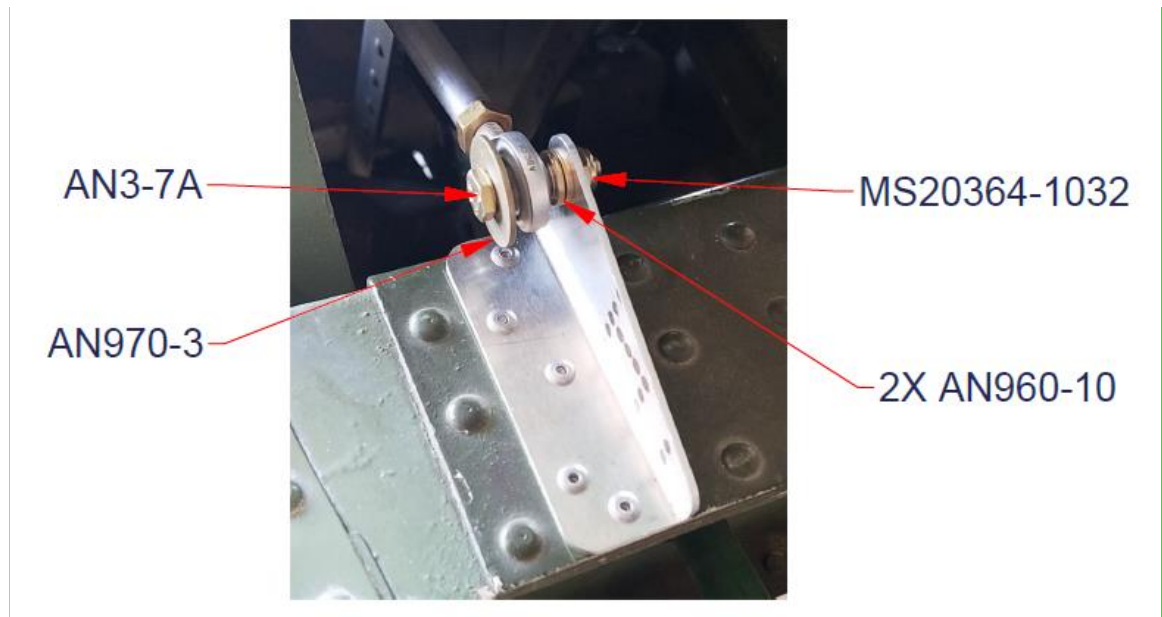

11.7.7. Attach the 6 pin link sensor connector to the link sensor.

11.7.8. Attach the 6 pin link sensor connector to the pitch servo.

11.7.9. Install pitch servo 9 pin connector from wiring harness to pitch servo. Tighten two retention screws to approximately 2-3 inch pounds.

11.7.10. Place pitch servo in pitch servo mounting bracket. Ensure that the servo arm fits between the servo stops built into the pitch servo bracket. See the figure below for proper pitch servo / pitch servo mounting bracket configuration:

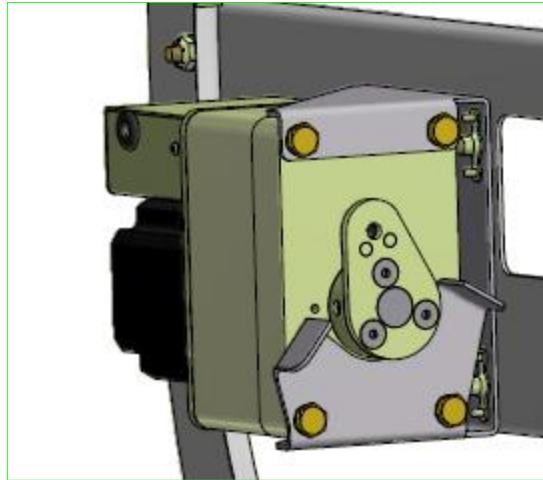

11.7.11. Install pitch servo using four (4) AN3-3A bolts and four (4) MS35333-39 lock washers. Prior to installation of the four (4) bolts, apply Loctite 242 or equivalent thread locker to the bolts. Torque the bolts to 20-25 inch pounds.

11.7.12. Temporarily attach the pitch pushrod assembly to the pitch servo arm as shown below. Do not torque the bolt yet!

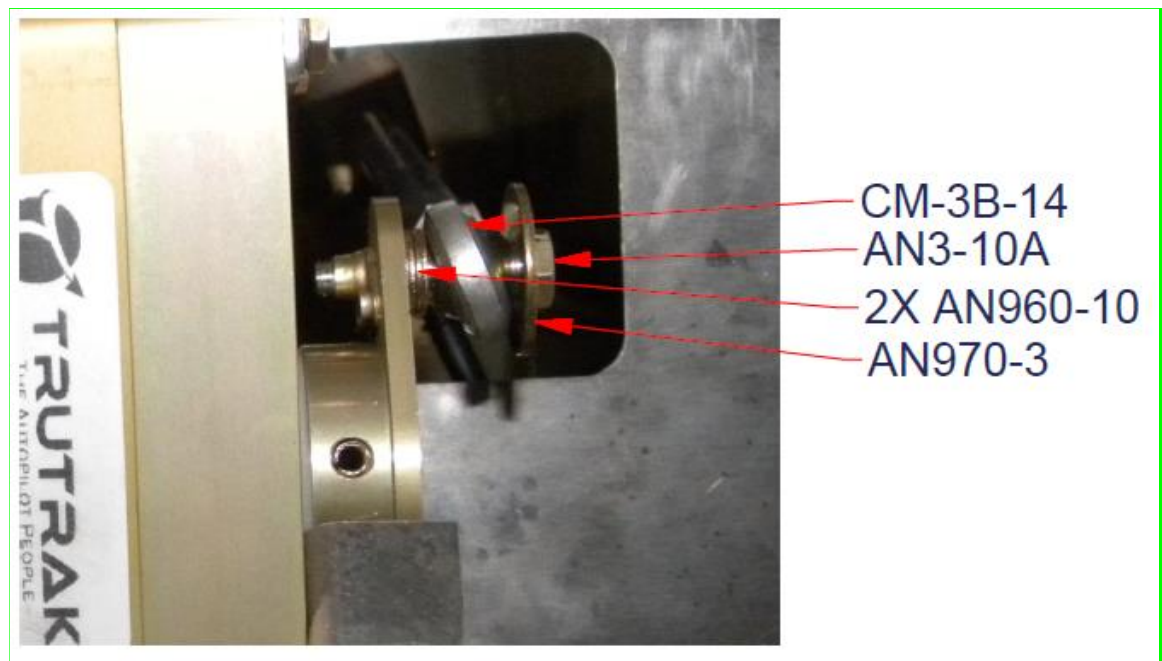

11.7.13. Check the full up and down flight control deflections. Ensure that full stabilator travel is possible without the servo arm contacting the servo stops

built into the pitch servo bracket. If full travel is not possible, remove the bolt in step 12 and adjust the length of the pushrod by adjusting the rod ends at one or both ends of the pushrod.

11.7.14. Once full control travel is verified, torque the jam nuts at both ends of the pitch pushrod assembly as well as the AN3-10A bolt connecting the pitch servo pushrod assembly to the pitch servo arm to 20-25 inch pounds.

11.7.15. Replace the tailcone removed in step 5.

11.7.16. Replace inspections covers removed in step 4.

11.7.17. Replace baggage compartment bulkhead removed in step 5.

11.7.18. Reconnect aircraft battery.

11.7.19. Perform Task 04-24-01 and Task 04-24-06.

11.8. Task 11-23-06 – Removal of Cessna 177 Link Sensor

11.8.1. Shut down aircraft power and disconnect the aircraft battery.

11.8.2. Refer to the Cessna 177 Vizion Pitch IPC in Section 11.16 of this document for illustrated parts catalog.

11.8.3. The link sensor (8000-177) is located in the aft portion of the fuselage aft of station 263.0. The link sensor is part of the C177 Pitch Push Rod (7200-098) and is not serviceable as a separate item. Do not attempt to disassemble the push rods from the link sensor.

11.8.4. Remove the inspections covers forward and aft of station 263.0 on both sides of the aircraft.

11.8.5. Remove the tailcone to expose the upper center portion of the stabilator.

11.8.6. Disconnect the 6 pin sensor connector / harness from link sensor.

11.8.7. Disconnect the pitch pushrod by removing the AN3-10A pitch pushrod bolt, two (2) AN960-10 washers, and AN970-3 washer from the pitch servo arm.

11.8.8. Remove the AN3-7A bolt, two (2) AN960-10 washers, and AN970-3 washer to disconnect the pitch push rod assembly from the pitch arm on the stabilator.

11.8.9. Remove the pitch push rod assembly

11.8.10. If replacing the push rod assembly remove the CM-3B-14 Rod End Bearings (P/N 2510-052) and jam nuts from each end of the pitch push rod assembly.

11.8.11. Ensure that 6 pin connector / harness is adequately secured and will not interfere with aircraft controls.

11.8.12. Replace the tailcone removed in step 5.

11.8.13. Replace inspections covers removed in step 4.

11.8.14. Reconnect aircraft battery.

11.8.15. All parts should now be safely stored until needed for installation.

11.9. Task 11-23-07 – Installation of Cessna 177 Link Sensor

11.9.1. Shut down aircraft power and disconnect the aircraft battery.

11.9.2. Refer to the Cessna 177 Vizion Pitch IPC in Section 11.16 of this document for illustrated parts catalog.

11.9.3. The link sensor (8000-177) is located in the aft portion of the fuselage aft of station 263.0. The link sensor is part of the C177 Pitch Push Rod (7200-098) and is not serviceable as a separate item. Do not attempt to disassemble the push rods from the link sensor.

11.9.4. Remove the inspections covers forward and aft of station 263.0 on both sides of the aircraft.

11.9.5. Remove the tailcone to expose the upper center portion of the stabilator.

11.9.6. Fully thread AN315-4 jam nuts on two (2) CM-3B-14 Rod End Bearings (P/N 2510-052).

11.9.7. Thread one of the CM-3B-14 Rod End Bearings (P/N 2510-052) half way into each end of the Cessna 177 Pitch Push Rod Assembly (P/N 7200-098).

11.9.8. Attach the forward end of the Cessna 177 Pitch Push Rod Assembly (P/N 7200-098) to the pitch servo arm (P/N 7200-091) as shown below. Torque AN3-10A bolt to 20-25 in-lb.

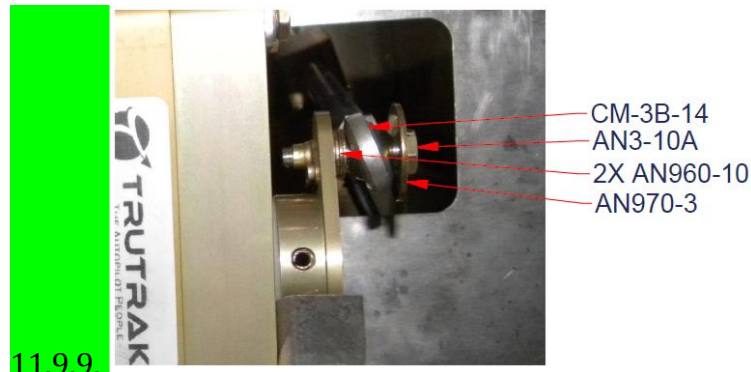

11.9.10. Place the stabilator in the full down position. Adjust the rod ends on the push rod assembly so that the rear rod end bearing aligns with the hole in the pitch arm on the stabilator and the servo arm has approximately 1/8" clearance from the rear servo stop.

11.9.11. Secure the rear rod end bearing to the Cessna 177 Pitch Arm (P/N 1450-114) as shown below. Verify that the servo arm does not contact either stop when the stabilator is at full up or down deflection. If necessary adjust the rod ends to allow clearance. Torque AN3-7A bolt to 20-25 in-lb.

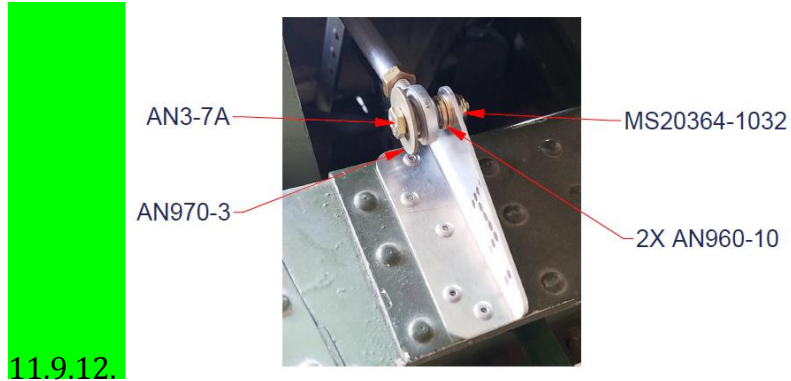

11.9.12.

11.9.13. Rotate the Cessna 177 Pitch Push Rod Assembly (P/N 7200-098) so that the 6 pin connector is pointed downward.

11.9.14. Use blue threadlocker (Loctite 242 or equivalent) and torque the jam nuts to 20-25 in-lb. Verify that both rod ends can move freely throughout full stabilator travel.

11.9.15. Attach the 6 pin link sensor connector to the link sensor.

11.9.16. Ensure that 6 pin connector / harness is adequately secured and will not interfere with aircraft controls.

11.9.17. Replace the tailcone removed in step 5.

11.9.18. Replace inspections covers removed in step 4.

11.9.19. Reconnect aircraft battery.

11.9.20. Perform Task 04-24-01, Task 04-24-06, and Task 04-24-07.

12. Appendix C – Cessna 175/172 All Models

12.1. Cessna 175/172 All Models Additional Installation Components

1450-107	Cessna 172 Upper Roll Bracket
1450-108	Cessna 172 Lower Roll Bracket
7200-088	Cessna 172 Roll Inboard Pushrod
7200-090	Cessna 172 Roll Outboard Pushrod
7200-091	Cessna 172 Roll Servo Arm
1450-121	Cessna 172 Early Aft Pitch Servo Bracket
1420-209	1.5" PMA Servo Arm
1420-277	Cessna 172 Early Pitch Clamp Link Sensor Half
1420-288	Cessna 172 Early Pitch Clamp Half
7200-100	Cessna 172 Early Fore Pitch Bracket Assembly
7200-101	Cessna 172 Early Pitch Servo Bracket Assembly
7200-099	Cessna 172 Early Pitch Push Rod

12.2. Cessna 175/172 All Models Equipment Locations

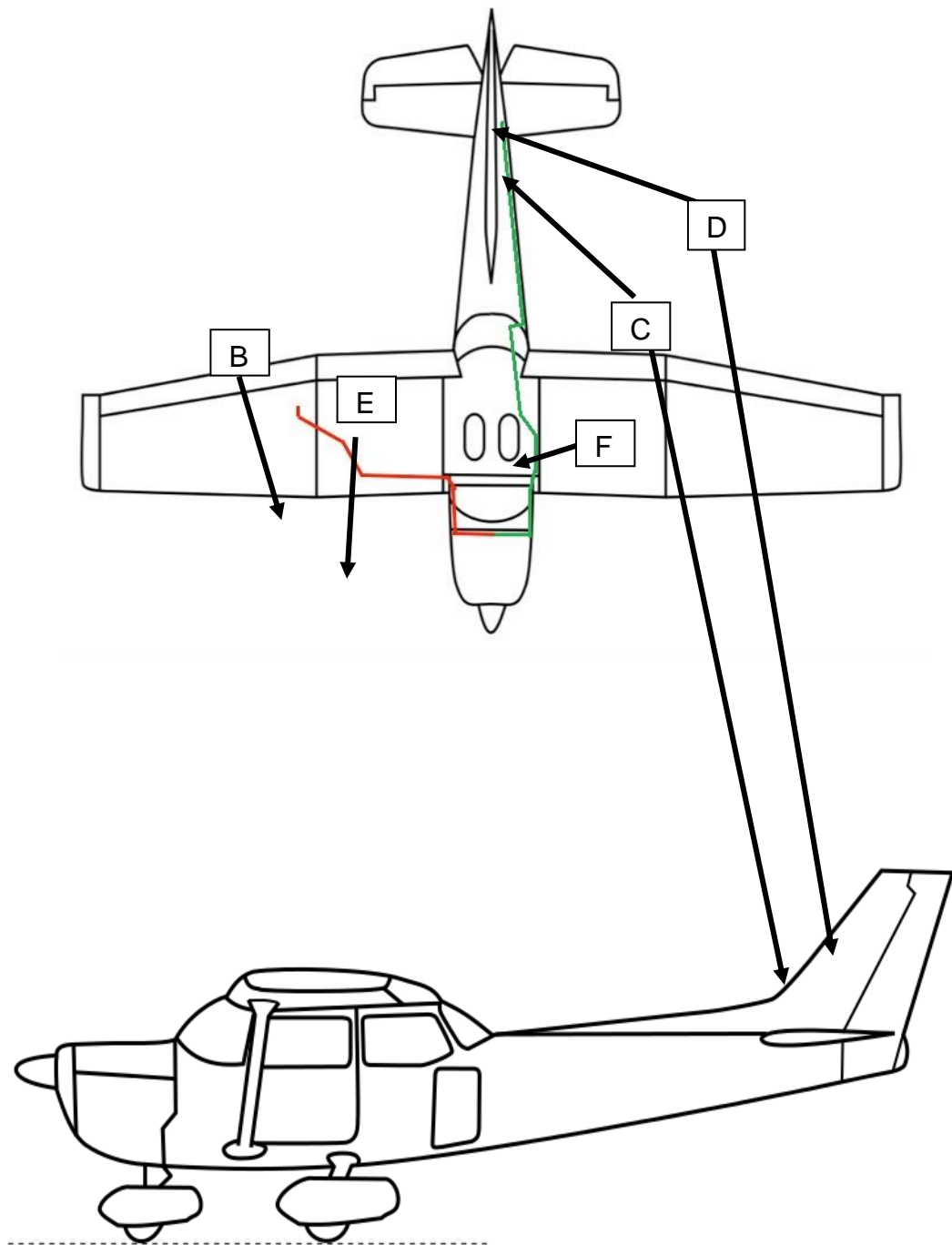

The above locations are general guidance. Actual equipment locations may vary per aircraft.

Wiring harness routing: The roll harness routing is shown by line E. This portion passes to right side of the aircraft and up into the right wing following the main wiring bundle up the side of the aircraft and through the wing. The pitch harness routing is shown by line F. This portion runs through the left side of the floor and fuselage to the tail.

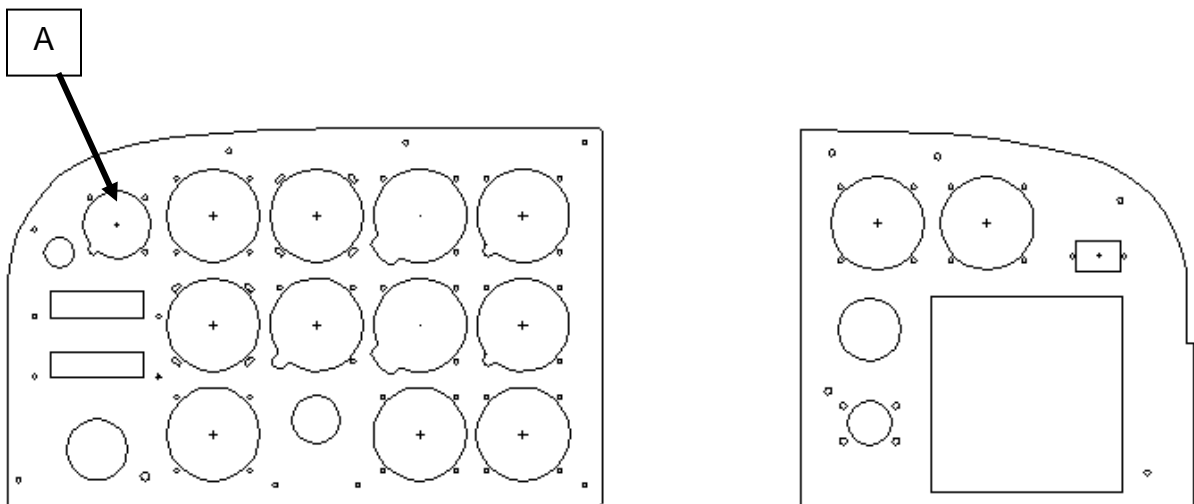

LRU Definitions

A	Vizion Autopilot
B	12 Volt Roll Servo (8100-064) OR 24 Volt Roll Servo (8100-065)
C	12 Volt Pitch Servo (8100-064) OR 24 Volt Pitch Servo (8100-065)
D	Link Sensor (8000-177)
E	Roll Servo Wiring Harness Location
F	Pitch Servo Wiring Harness Location

12.3. Task 12-23-01 – Cessna 175/172 All Models Autopilot Configuration

12.3.1. If your unit is being reinstalled into the aircraft it was removed from, and no corrective action has been performed on the unit, no further

configuration is necessary. Operation check the unit per Task 04-24-01 in Section 4.1.

12.3.2. If the unit was not previously installed in the aircraft, or has been serviced, perform the following steps:

Configure Vizion Autopilot

The Vizion autopilot has the adjustable gain settings to fly nearly any aircraft in which it may be installed, therefore it is imperative that it be configured to properly fly the aircraft. Refer to the Vizion PMA Installation Guide – C175/172 All Models Appendix C (listed under reference documentation in section 1.2 of this document) for configuration settings and procedures.

12.4. Task 12-23-02 – Removal of Cessna 175/172 All Models Roll Servo

12.4.1. Shut down aircraft power and disconnect the aircraft battery.

12.4.2. Refer to the Cessna 172 F – S Vizion Roll IPC in Section 10.15 of this document for illustrated parts catalog.

12.4.3. The roll servo (8100-064 or 8100-065) is located in the right wing just forward of the inboard end of the right aileron.

12.4.4. Remove the inspection cover on the lower right wing skin located forward of the inboard end of the right aileron.

12.4.5. Remove the AN3-7A bolt holding the pushrod to the roll servo arm.

12.4.6. Remove the four (4) AN3-3A bolts and four (4) MS35333-39 lock washers holding the roll servo (8100-064) to the roll servo bracket.

12.4.7. Remove the electrical connector from the back of the servo.

12.4.8. Remove the servo through the inspection hole.

12.4.9. If the roll servo is being replaced immediately, proceed to step three (3) of the roll servo installation instructions.

If the servo is being removed for repair or service, the pushrod must also be removed using the following steps.

12.4.10. Remove the inspection cover on the lower right wing skin located forward of the outboard end of the right aileron.

12.4.11. Loosen the jam nut on the end of the roll pushrod.

12.4.12. Unscrew the pushrod from the rod end bearing.

12.4.13. Remove the AN3-16A bolt, AN970-3 washer, MM-3-300 rod end bearing, and the two (2) AN960-10 washers.

12.4.14. Replace the AN3-16A bolt with an appropriate length AN3 bolt.

12.4.15. Working through the already open inboard inspection hole, disassemble the pushrod (it is a two-part assembly) by removing the two (2) AN3-7A bolts and MS20364-1032 nuts.

12.4.16. Remove both sections of pushrod through the inspection hole.

12.4.17. Verify that the wiring harness is properly secured and will not interfere with the aircraft control cables.

12.4.18. Reinstall both inspection covers.

12.4.19. Reconnect aircraft battery.

12.4.20. All parts should now be safely stored until needed for installation.

12.5. Task 12-23-03 – Installation of Cessna 175/172 All Models Roll Servo

12.5.1. Shut down aircraft power and disconnect the aircraft battery.

12.5.2. Refer to the Cessna 172 F – S Vizion Roll IPC in Section 10.15 of this document for illustrated parts catalog.

12.5.3. Remove the inspection cover on the lower right wing skin located forward of the outboard end of the right aileron.

12.5.4. Remove the inspection cover on the lower right wing skin located forward of the inboard end of the right aileron.

12.5.5. Ensure that wiring harness is free to connect to servo at inboard inspection hole.

12.5.6. Insert roll servo through inboard inspection hole.

12.5.7. Install roll servo 9 pin connector from wiring harness to roll servo. Tighten two retention screws to approximately 2-3 inch pounds. Ensure that wiring harness will not be wrapped around any aircraft cables or the roll servo pushrod.

12.5.8. Place roll servo in roll servo mounting bracket. Ensure that the servo arm fits between the servo stops built into the roll servo bracket. See the figure below for proper roll servo / roll servo mounting bracket configuration:

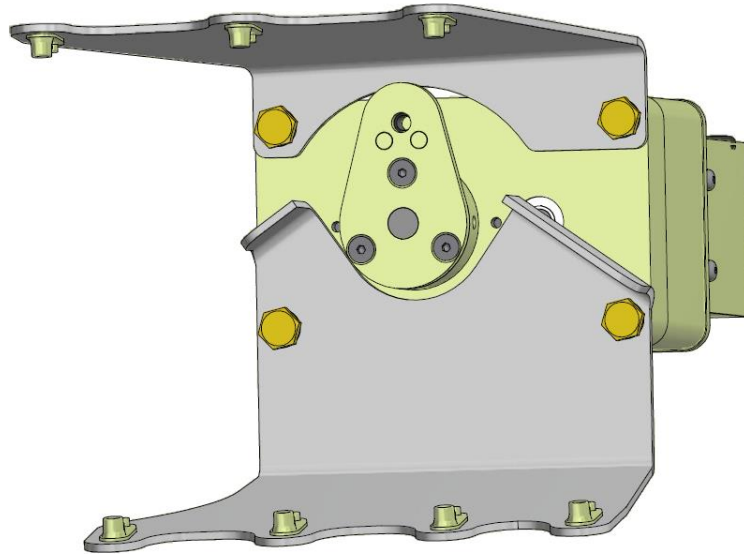

12.5.9. Attach roll servo to roll servo bracket using four (4) AN3-3A bolts and four (4) MS35333-39 lock washers. Prior to installation of the four (4) bolts, apply Loctite 242 or equivalent thread locker to the bolts. Tighten the bolts to 20-25 inch pounds.

12.5.10. If the roll servo pushrod is still in the aircraft because the roll servo is being immediately replaced after removal, proceed to step 16. Otherwise, proceed to step 11.

12.5.11. Insert both sections of the roll servo pushrod through the inboard inspection hole. The inboard portion of the pushrod contains two aluminum inserts and should still contain one rod end bearing, and the outboard contains only one aluminum insert.

12.5.12. Assemble the pushrod using two (2) AN3-7A bolts and two (2) MS20364-1032 nuts. The threaded portion of the inboard pushrod half (the end with a rod end bearing still installed) goes toward the servo. The threaded portion of the outboard portion of the pushrod half goes toward the bellcrank. Torque the bolts to 20-25 inch pounds.

12.5.13. Attach the assembled pushrod to the bellcrank. Remove the rear aileron bellcrank cable attachment bolt and replace with one (1) AN3-16A, one (1) AN970-3, one (1) MM-3-300, and two (2) AN960-10. Torque the bolt to 20-25 inch pounds.

12.5.14. Thread one (1) AN345-10 nut all the way onto the MM-3-300 rod end bearing.

12.5.15. Thread the pushrod assembly onto the MM-3-300 rod end bearing (the final length of the pushrod will be adjusted in the next step).

12.5.16. Temporarily attach the pushrod to the roll servo arm using one (1) AN3-7A, one (1) AN970-3, and two (2) AN960-10. Do not torque the bolt yet!

12.5.17. Check the full left and right control deflections. Ensure that full aileron travel is possible without the servo arm contacting the servo stops built into the roll servo bracket. If full travel is not possible, remove the bolt in step 16 and adjust the length of the pushrod by adjusting the rod ends at one or both ends of the pushrod.

12.5.18. Once full control travel is verified, torque the jam nuts at both ends of the pushrod to 20-25 inch pounds as well as the bolt connecting the roll servo pushrod to the roll servo arm.

12.5.19. Verify that the wiring harness is properly secured and will not interfere with the aircraft control cables.

12.5.20. Reinstall both inspection covers.

12.5.21. Reconnect aircraft battery.

12.5.22. Perform Task 04-24-01 and Task 04-24-05.

12.6. Task 12-23-04 – Removal of Cessna 175/172 All Models Pitch Servo

12.6.1. Shut down aircraft power and disconnect the aircraft battery.

12.6.2. Refer to the Cessna 175/172 All Models Vizion Pitch IPC in Section 12.16 of this document for illustrated parts catalog.

12.6.3. The pitch servo (8100-064 or 8100-065) is located on the horizontal bulkhead directly below the vertical stabilizer.

12.6.4. Remove both tail fairings.

12.6.5. Disconnect 6 pin connector from link sensor.

12.6.6. Disconnect the 9 pin connector from the pitch servo.

12.6.7. Ensure that 9 pin connector / harness is adequately secured and will not interfere with aircraft controls.

12.6.8. Remove the lockwire from the AN4H-4A bolt on the Pitch Clamp Link Sensor Half (P/N 1420-227).

12.6.9. Remove the (8) AN3-5A bolts and (8) MS20364-1032 nut from the Pitch Clamp Link Sensor Half (P/N 1420-227) and Pitch Clamp Half (P/N 1420-228).

12.6.10. Remove the (AN3-10A), (3) AN960-10, (AN970-3) and (MS20364-1032) from the pitch servo arm and pushrod end.

12.6.11. Remove the pushrod assembly with the link sensor cable.

12.6.12. Remove the (2) AN3-7A bolts from the beacon resistor.

12.6.13. Remove the six (6) AN3-3A bolts attaching the Cessna 172 Early Aft Pitch Bracket (P/N 1450-121) and C172 Early Fore Pitch Bracket Assembly (P/N 7200-100) to the C172 Early Pitch Servo Bracket Assembly (P/N 7200-101).

12.6.14. Remove PMA Servo (P/N 8100-064 OR 8100-065) and C172 Early Pitch Servo Bracket Assembly (P/N 7200-101) from the aircraft as an assembly.

12.6.15. Remove PMA Servo (P/N 8100-064 OR 8100-065) from C172 Early Pitch Servo Bracket Assembly (P/N 7200-101) by removing the (4) AN3-3A bolts and (4) MS35333-39 lock washers.

12.6.16. Reinstall the beacon resistor using (2) AN3-7A. Tighten the bolts to 20-25 inch pounds.

12.6.17. Install both tail fairings.

12.6.18. Reconnect aircraft battery.

12.6.19. All parts should now be safely stored until needed for installation.

12.7. Task 12-23-05 – Installation of Cessna 175/172 All Models Pitch Servo

12.7.1. Shut down aircraft power and disconnect the aircraft battery.

12.7.2. Refer to the Cessna 175/172 All Models Vizion Pitch IPC in Section 12.16 of this document for illustrated parts catalog.

12.7.3. Remove both tail fairings.

12.7.4. Install PMA Servo (P/N 8100-064 OR 8100-065) into the C172 Early Pitch Servo Bracket Assembly (P/N 7200-101) using (4) AN3-3A bolts and (4) MS35333-39 lock washers. Prior to installation of the four (4) bolts, apply Loctite 242 or equivalent thread locker to the bolts. Tighten the bolts to 20-25 inch pounds.

12.7.5. Remove the (2) AN3-7A bolts from the beacon resistor.

12.7.6. Install PMA Servo (P/N 8100-064 OR 8100-065) and C172 Early Pitch Servo Bracket Assembly (P/N 7200-101) into the aircraft as an assembly.

12.7.7. Install six (6) AN3-3A bolts attaching the Cessna 172 Early Aft Pitch Bracket (P/N 1450-121) and C172 Early Fore Pitch Bracket Assembly (P/N 7200-100) to the C172 Early Pitch Servo Bracket Assembly (P/N 7200-101). Tighten the bolts to 20-25 inch pounds.

12.7.8. Reinstall the beacon resistor using (2) AN3-7A bolts. Tighten the bolts to 20-25 inch pounds.

12.7.9. Install the pushrod to the servo arm with (AN3-10A), (3) AN960-10, (AN970-3) and (MS20364-1032) as seen below. Tighten the nut to 20-25 inch pounds.

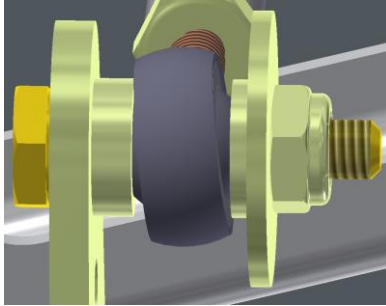

12.7.10. Hold the yoke in the full forward position and the servo arm 1/16 inch from the rear servo stop as seen below.



12.7.11. Clamp the elevator cable between the C172 Early Pitch Clamp Link Sensor Half (P/N 1420-227) and C172 Early Pitch Clamp Half (P/N 1420-228) and fasten with 8 AN3-5A and 8 MS20364-1032.

12.7.12. Tighten the fasteners on each side of the cable evenly so the spacing between each clamp half is even and torque each fastener to 20-25 in-lb.

12.7.13. Move the yoke to the full aft position and ensure the servo arm is not in contact with the forward servo stop. See figure 6-14. If the servo arm is contacting the servo stop perform factory setup procedure for elevator stops.

12.7.14. Lockwire the AN4H-4A bolt on the Pitch Clamp Link Sensor Half (P/N 1420-227) through the cable clamp.

12.7.15. Install pitch servo 9 pin connector from wiring harness to pitch servo. Tighten two retention screws to approximately 2-3 inch pounds.

12.7.16. Attach the 6 pin link sensor cable to the pitch servo and link sensor.

12.7.17. Ensure the link sensor cable is properly secured.

12.7.18. Install both tail fairings.

12.7.19. Reconnect aircraft battery.

12.7.20. Perform Task 04-24-01 and Task 04-24-06.

12.8. Task 12-23-06 – Removal of Cessna 175/172 All Models Link Sensor

- 12.8.1. Shut down aircraft power and disconnect the aircraft battery.
- 12.8.2. Refer to the Cessna 175/172 All Models Pitch IPC in Section 12.16 of this document for illustrated parts catalog.
- 12.8.3. Remove both tail fairings.
- 12.8.4. Disconnect 6 pin connector from servo.
- 12.8.5. Remove the lockwire from the AN4H-4A bolt on the Pitch Clamp Link Sensor Half (P/N 1420-227).
- 12.8.6. Remove the (8) AN3-5A bolts and (8) MS20364-1032 nut from the Pitch Clamp Link Sensor Half (P/N 1420-227) and Pitch Clamp Half (P/N 1420-228).
- 12.8.7. Remove the (AN3-10A), (3) AN960-10, (AN970-3) and (MS20364-1032) from the pitch servo arm and pushrod end.
- 12.8.8. Remove the pushrod assembly with the link sensor cable.
- 12.8.9. Install both tail fairings.
- 12.8.10. Reconnect aircraft battery.
- 12.8.11. Parts should now be safely stored until needed for installation.

12.9. Task 12-23-07 – Installation of Cessna 175/172 All Models Link Sensor

- 12.9.1. Shut down aircraft power and disconnect the aircraft battery.
- 12.9.2. Refer to the Cessna 175/172 All Models Pitch IPC illustrated parts catalog.
- 12.9.3. Remove both tail fairings.
- 12.9.4. Install the pushrod to the servo arm with (AN3-10A), (3) AN960-10, (AN970-3) and (MS20364-1032) as seen below. Tighten the nut to 20-25 inch pounds.

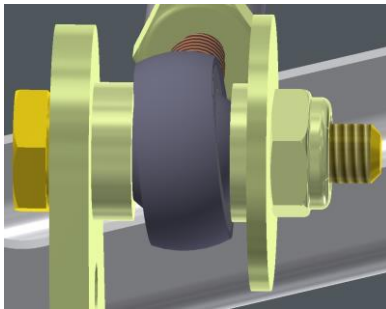

- 12.9.5. Hold the yoke in the full forward position and the servo arm 1/16 inch from the rear servo stop as seen below.



12.9.6. Clamp the elevator cable between the C172 Early Pitch Clamp Link Sensor Half (P/N 1420-227) and C172 Early Pitch Clamp Half (P/N 1420-228) and fasten with 8 AN3-5A and 8 MS20364-1032.

12.9.7. Tighten the fasteners on each side of the cable evenly so the spacing between each clamp half is even and torque each fastener to 20-25 in-lb.

12.9.8. Move the yoke to the full aft position and ensure the servo arm is not in contact with the forward servo stop. See figure 6-14. If the servo arm is contacting the servo stop perform factory setup procedure for elevator stops.

12.9.9. Lockwire the AN4H-4A bolt on the Pitch Clamp Link Sensor Half (P/N 1420-227) through the cable clamp.

12.9.10. Attach the 6 pin link sensor cable to the link sensor.

12.9.11. Attach the 6 pin link sensor cable to the pitch servo.

12.9.12. Ensure the link sensor cable is properly secured.

12.9.13. Install both tail fairings.

12.9.14. Reconnect aircraft battery.

12.9.15. Perform Task 04-24-01, Task 04-24-06, and Task 04-24-07.

13. Appendix D – Piper PA-28

13.1. Piper PA-28 Additional Installation Components

1420-229	PMA Cable Clamp Half Countersunk
1420-230	PMA Cable Clamp Half Plain
2520-010	6" Push Rod
2520-013	8" Push Rod
7200-096	2.5" PMA Servo Arm Assembly
7200-097	2" PMA Servo Arm Assembly
7200-108	PA-28 Roll Bracket Assembly
7200-103	PA-28 Pitch Bracket Assembly
7200-104	PA-28 Bellcrank

13.2. PA-28 Equipment Locations

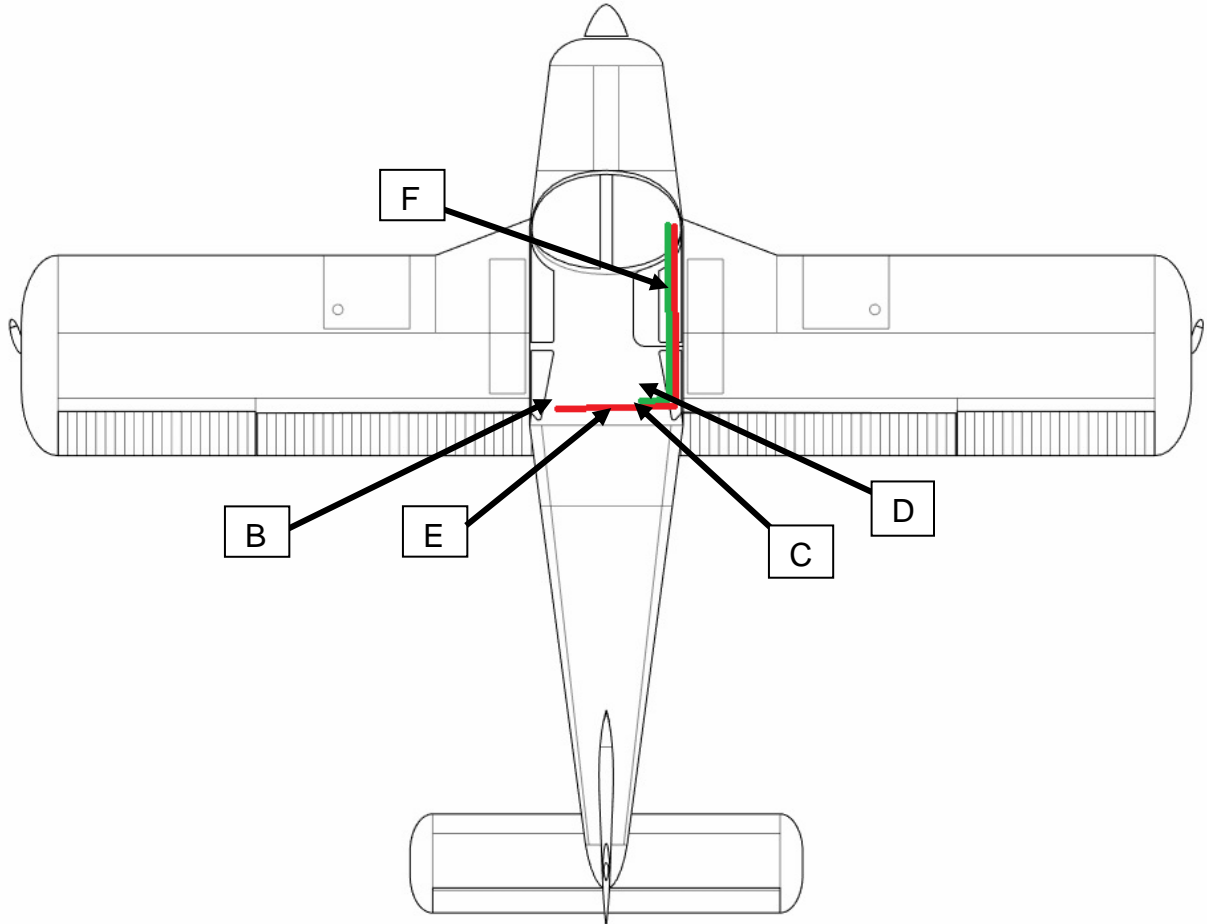

The above locations are general guidance. Actual equipment locations may vary per aircraft.

Wiring harness routing: The roll harness routing is shown in red by line E. This portion passes to the right side of the aircraft and through the spar to the roll servo. The pitch harness routing is shown in green by line F. This portion passes to the right side of the aircraft and through the spar to the pitch servo.

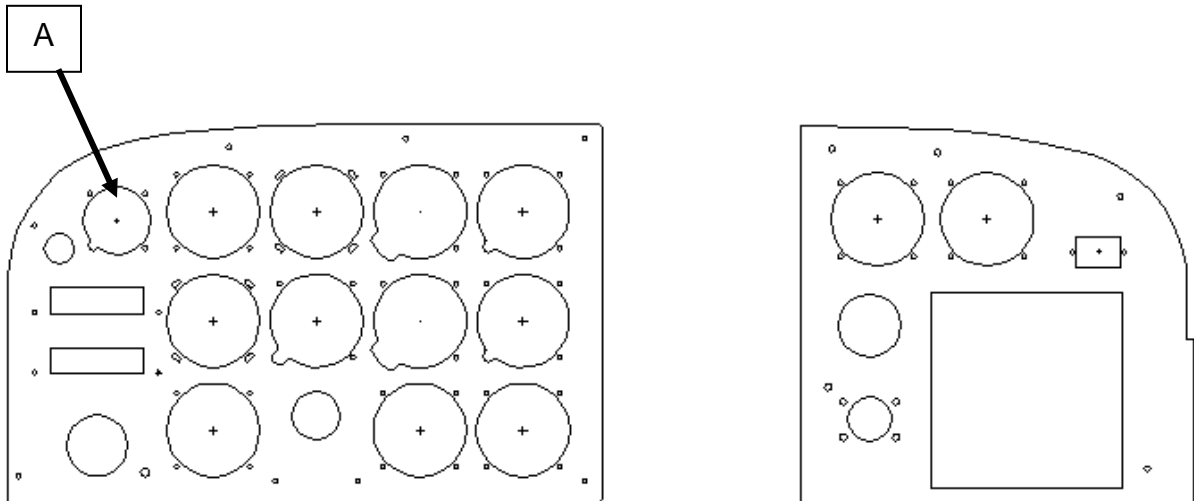

LRU Definitions

A	Vizion Autopilot
B	12 Volt Roll Servo (8100-064) OR 24 Volt Roll Servo (8100-065)
C	12 Volt Pitch Servo (8100-064) OR 24 Volt Pitch Servo (8100-065)
D	Link Sensor (8000-177)
E	Roll Servo Wiring Harness Location
F	Pitch Servo Wiring Harness Location

13.3. Task 13-23-01 – Piper PA-28 Autopilot Configuration

13.3.1. If your unit is being reinstalled into the aircraft it was removed from, and no corrective action has been performed on the unit, no further configuration is necessary. Operation check the unit per Task 04-24-01 in Section 4.1.

13.3.2. If the unit was not previously installed in the aircraft, or has been serviced, perform the following steps:

Configure Vizion Autopilot

The Vizion autopilot has the adjustable gain settings to fly nearly any aircraft in which it may be installed, therefore it is imperative that it be configured to properly fly the aircraft. Refer to the Vizion PMA Installation Guide – PA-28 Appendix D for configuration settings and procedures.

13.4. Task 13-23-02 – Removal of Piper PA-28 Roll Servo

13.4.1. Shut down aircraft power and disconnect the aircraft battery.

- 13.4.2. Refer to the Vizion PMA Installation Guide PA-28 Appendix D (242) for illustrated parts catalog.
- 13.4.3. The roll servo (8100-064 or 8100-065) is located under the rear seat on the left side of the aircraft.
- 13.4.4. Remove the rear seat.
- 13.4.5. Remove the electrical connector from the back of the servo.
- 13.4.6. Remove the AN3-7A bolt holding the pushrod to the roll servo arm.
- 13.4.7. Remove the four (2) AN3-3A bolts, (2) 10-32 x 3/8 Socket Head Cap Screws, and four (4) MS35333-39 lock washers holding the roll servo (8100-064 or 8100-065) to the roll servo bracket assembly.
- 13.4.8. Remove the AN4-6A bolt securing the PA-28 bellcrank (7200-104) to the PA-28 roll bracket assembly (7200-102).
- 13.4.9. Remove the (6) AN526C832R10 screws and MS20361-832 nuts securing the roll bracket assembly to the aircraft.
- 13.4.10. Remove the roll bracket assembly and roll servo from the aircraft.
- 13.4.11. If the roll servo is being replaced immediately, proceed to step 6 of the roll servo installation instructions. If the servo is being removed for repair or service, the PA-28 roll bracket assembly must be replaced and the pushrod must be removed using the following steps.
- 13.4.12. Remove the AN3 hardware securing the roll push rod to the aileron cable clamp.
- 13.4.13. Replace the AN3-10A bolt from the aileron cable clamp with an appropriate length AN3 bolt and torque to 20-25 in-lb.
- 13.4.14. Replace the roll bracket assembly using (6) AN526C832R10 screws and MS20361-832 nuts. Torque to 18-20 in-lb.
- 13.4.15. Reconnect the PA-28 bellcrank to the roll servo bracket using an AN4-6A bolt with Loctite 242 or equivalent threadlocker and torque to 50-70 in-lb.
- 13.4.16. Secure wiring harness to prevent interference with flight controls.
- 13.4.17. Replace the rear seat.
- 13.4.18. Reconnect aircraft battery.
- 13.4.19. All parts should now be safely stored until needed for installation.

13.5. Task 13-23-03 – Installation of Piper PA-28 Roll Servo

- 13.5.1. Shut down aircraft power and disconnect the aircraft battery.
- 13.5.2. Refer to the Vizion PMA Installation Guide PA-28 Appendix D (242) for illustrated parts catalog.
- 13.5.3. Remove the rear seat.

13.5.4. Remove the AN4-6A bolt securing the PA-28 bellcrank (7200-104) to the PA-28 roll bracket assembly (7200-102).

13.5.5. Remove the (6) AN526C832R10 screws and MS20361-832 nuts securing the roll bracket assembly to the aircraft.

13.5.6. Place the roll servo under the flap tube and attach to the PA-28 roll bracket assembly using two AN3-3A bolts in the upper holes and two 10-32 x 3/8 socket head cap screws in the lower holes. Place MS35333-39 lock washers under all of the bolts and apply Loctite 242 or equivalent to all bolts. Torque to 20-25 in-lb.

13.5.7. Install roll servo 9 pin connector from wiring harness to roll servo.

13.5.8. Attach the roll servo bracket to the aircraft using (6) AN526C832R10 screws and MS20361-832 nuts. Torque to 18-20 in-lb.

13.5.9. Reconnect the PA-28 bellcrank to the roll servo bracket using an AN4-6A bolt. Use Loctite 242 or equivalent threadlocker and torque to 50-70 in-lb.

13.5.10. If the roll servo pushrod is still in the aircraft because the roll servo is being immediately replaced after removal, proceed to step 14. Otherwise, proceed to step 11.

13.5.11. Remove the AN3 bolt placed in the aileron cable clamp during removal of the roll servo.

13.5.12. Attach one end of the pushrod to the aileron cable using hardware as shown below. Torque the AN3-10A bolt to 20-25 in-lb.

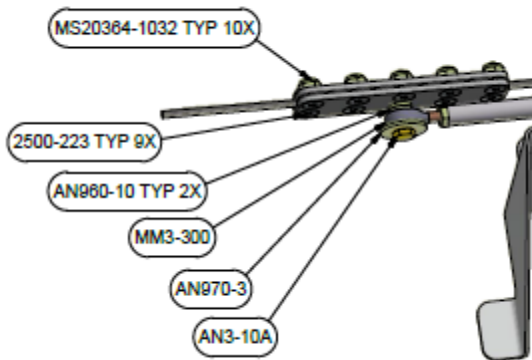

13.5.13. Attach the remaining end of the pushrod to the servo arm using hardware as shown below. Torque the AN3-10A bolt to 20-25 in-lb.

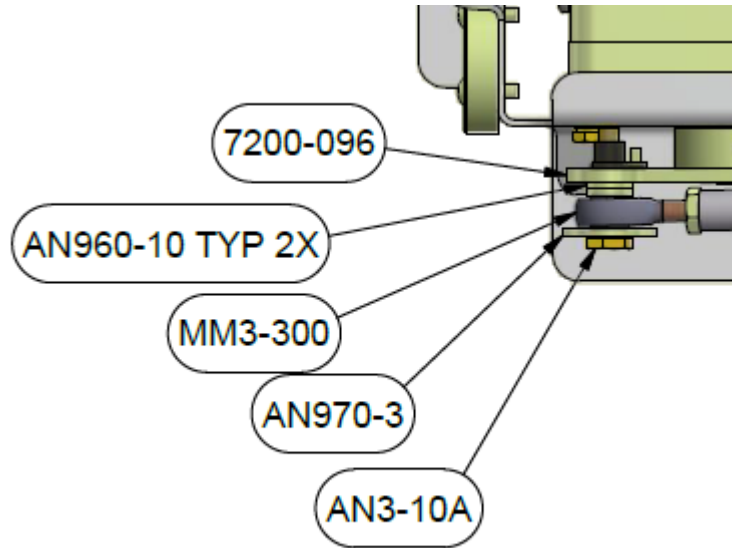

13.5.14. Check the full left and right control deflections. Ensure that full aileron travel is possible without the servo arm contacting the servo stops built into the roll servo bracket. If full travel is not possible, remove the bolt in step 16 and adjust the length of the pushrod by adjusting the rod ends at one or both ends of the pushrod.

13.5.15. Once full control travel is verified, torque the jam nuts at both ends of the pushrod to 20-25 inch pounds as well as the bolt connecting the roll servo pushrod to the roll servo arm.

13.5.16. Verify that the wiring harness is properly secured and will not interfere with the aircraft controls.

13.5.17. Replace the rear seat.

13.5.18. Reconnect aircraft battery.

13.5.19. Perform Task 04-24-01 and Task 04-24-05.

13.6. Task 13-23-04 – Removal of Piper PA-28 Pitch Servo

13.6.1. Shut down aircraft power and disconnect the aircraft battery.

13.6.2. Refer to the Vizion PMA Installation Guide PA-28 Appendix D (242) for illustrated parts catalog.

13.6.3. The pitch servo (8100-064 or 8100-065) is located under the rear seat on the right side of the aircraft.

13.6.4. Remove the rear seat.

13.6.5. Disconnect 6 pin connector from the pitch servo.

13.6.6. Disconnect the 9 pin connector from the pitch servo.

13.6.7. Ensure that 9 pin connector / harness is adequately secured and will not interfere with aircraft controls.

13.6.8. Disconnect the AN3-10A bolt securing the servo arm to the link sensor.

13.6.9. Remove the 4 AN3-3A bolts securing the servo to the pitch bracket assembly.

13.6.10. If the pitch servo is being replaced immediately, proceed to step 5 of the pitch servo installation instructions. If the pitch servo is not going to be replaced immediately safely store all parts until needed for installation and perform Task 13-23-06 to remove the PMA Link Sensor (P/N 8000-177).

13.7. Task 13-23-05 – Installation of Piper PA-28 Pitch Servo

13.7.1. Shut down aircraft power and disconnect the aircraft battery.

13.7.2. Refer to the Vizion PMA Installation Guide PA-28 Appendix D (242) for illustrated parts catalog.

13.7.3. The pitch servo (8100-064 or 8100-065) is located under the rear seat on the right side of the aircraft.

13.7.4. Remove the rear seat.

13.7.5. Install PMA Servo (P/N 8100-064 OR 8100-065) into the PA-28 pitch bracket assembly (P/N 7200-103) using (4) AN3-3A bolts and (4) MS35333-39 lock washers. Prior to installation of the four (4) bolts, apply Loctite 242 or equivalent thread locker to the bolts. Tighten the bolts to 20-25 inch pounds.

13.7.6. Perform Task 13-23-07 beginning in step 5.

13.7.7. Perform Task 04-24-01 and Task 04-24-06.

13.8. Task 13-23-06 – Removal of Piper PA-28 Link Sensor

13.8.1. Shut down aircraft power and disconnect the aircraft battery.

13.8.2. Refer to the Vizion PMA Installation Guide PA-28 Appendix D (242) for illustrated parts catalog.

13.8.3. The link sensor (8000-177) is located under the rear seat on the right side of the aircraft.

13.8.4. Remove the rear seat.

13.8.5. Disconnect 6 pin connector from the pitch servo.

13.8.6. Remove the AN3 hardware securing the link sensor to the servo arm and PA-28 bellcrank.

13.8.7. Remove the link sensor with the link sensor cable.

13.8.8. If the link sensor is being replaced immediately, proceed to step 6 of Task 13-23-07. If the link sensor is being removed for repair or service move to the next step.

- 13.8.9. Disconnect the 9 pin connector from the pitch servo.
- 13.8.10. Secure the pitch servo arm so that it cannot interfere with aircraft controls or the PA-28 bellcrank.
- 13.8.11. Replace the rear seat.
- 13.8.12. Reconnect aircraft battery.
- 13.8.13. Parts should now be safely stored until needed for installation.

13.9. Task 13-23-07 – Installation of Piper PA-28 Link Sensor

- 13.9.1. Shut down aircraft power and disconnect the aircraft battery.
- 13.9.2. Refer to the Vizion PMA Installation Guide PA-28 Appendix D (242) for illustrated parts catalog.
- 13.9.3. The link sensor (8000-177) is located under the rear seat on the right side of the aircraft.
- 13.9.4. Remove the rear seat.
- 13.9.5. Install large rod end bearings (P/N 2510-052) in the PMA link sensor (P/N 8000-177) as shown in below. Apply blue threadlocker (Loctite 242 or equivalent) to rod ends and torque AN315-4 nuts to 50-70 in-lb. Maintain orientation of large rod end bearings (P/N 2510-052) and hold the link sensor body and extension rod while torquing AN315-4 nuts.

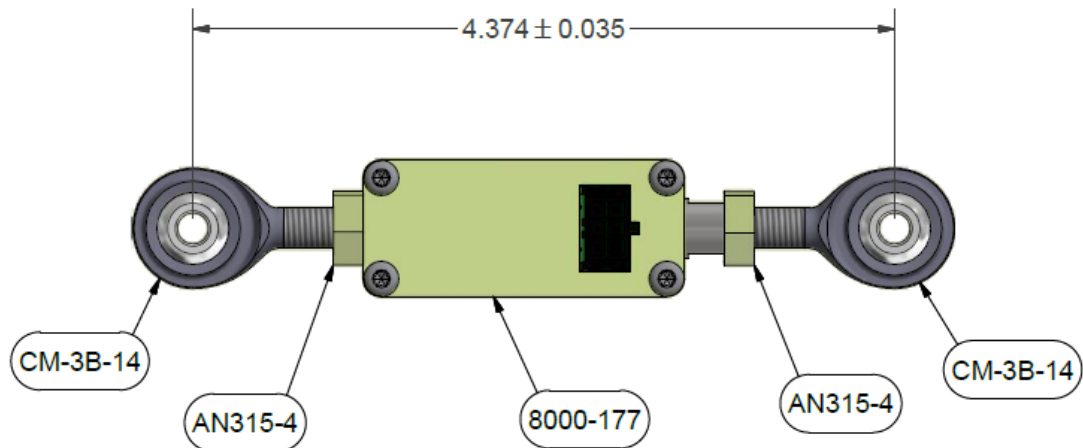

- 13.9.6. Install the Link Sensor to the servo arm and PA-28 bellcrank as shown below. Tighten fasteners to 20-25 inch pounds.

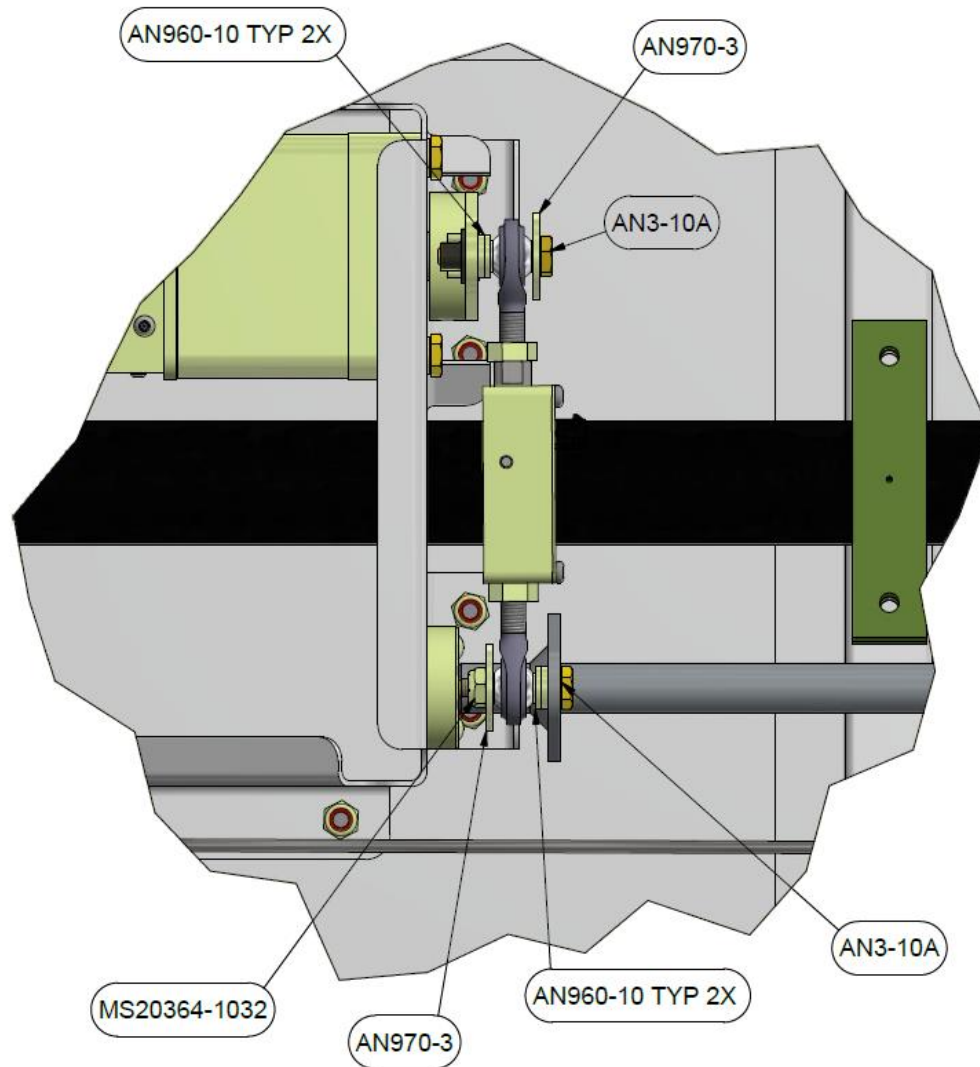

13.9.7. Ensure that the pitch controls move freely throughout full deflection without the servo arm contacting either the forward or aft servo stops.

13.9.8. Connect the 9 pin pitch servo wiring harness to the pitch servo.

13.9.9. Attach the 6 pin link sensor cable to the link sensor.

13.9.10. Attach the 6 pin link sensor cable to the pitch servo.

13.9.11. Ensure the link sensor cable is secured in a fashion that does not place excess strain on the connection to the link sensor and also prevents interference with the aircraft controls.

13.9.12. Replace the rear seat.

13.9.13. Reconnect aircraft battery.

13.9.14. Perform Task 04-24-01, Task 04-24-06, and Task 04-24-07.

14. Appendix E – Cessna 180, 182-182D, 185

14.1. Cessna 180, 182-182D, 185 Additional Installation Components

PART NUMBER	DESCRIPTION
7200-091	C172 Roll Servo Arm
2520-062	41" Push Rod .5" OD Tapped 10-32
2510-210	0.625 L X 0.375 OD X .199 ID Alum. Spacer
2510-208	0.250 L X 0.375 OD X 0.250 ID Alum. Spacer
1450-128	18X Lower Roll Bracket
1450-127	18X Upper Roll Bracket
7200-112	Early Model 18X Pitch Push Rod
7200-106	2.75" PMA Servo Arm Assembly
1450-129	Early 18X Pitch Bracket

14.2. Cessna 180, 182-182D, 185 Equipment Locations

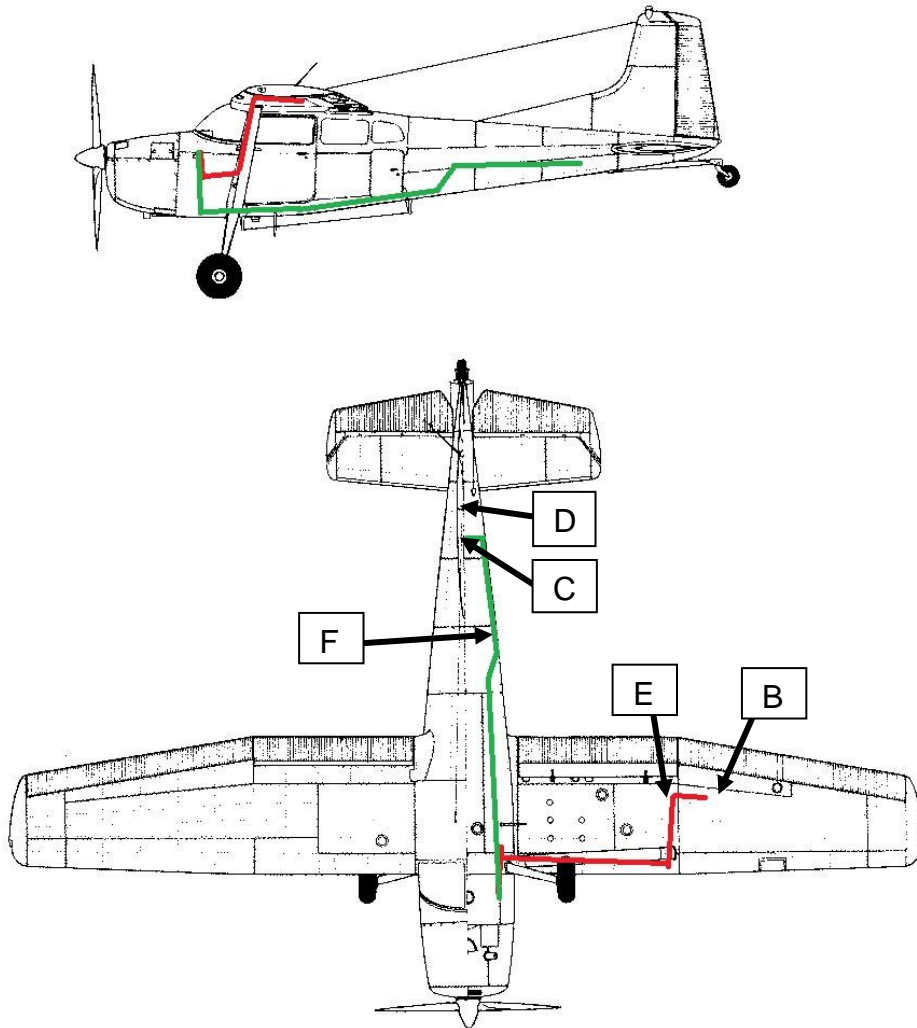

The above locations are general guidance. Actual equipment locations may vary per aircraft.

Wiring harness routing: The roll harness routing is shown in red by line E. This portion passes to the right side of the aircraft and through the spar to the roll servo. The pitch harness routing is shown in green by line F. This portion passes to the right side of the aircraft and through the spar to the pitch servo.

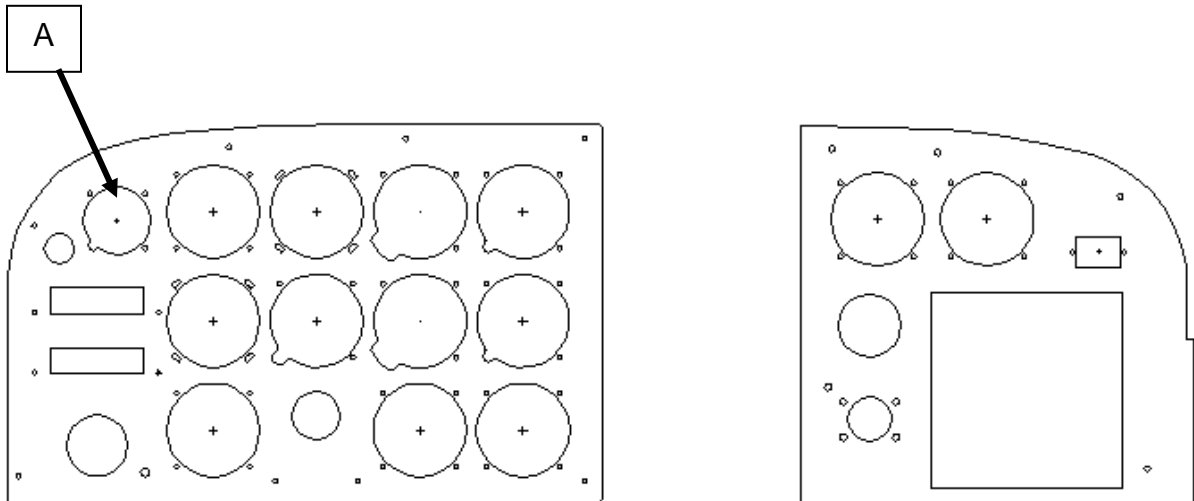

LRU Definitions

A	Vizion Autopilot
B	12 Volt Roll Servo (8100-064) OR 24 Volt Roll Servo (8100-065)
C	12 Volt Pitch Servo (8100-064) OR 24 Volt Pitch Servo (8100-065)
D	Link Sensor (8000-177)
E	Roll Servo Wiring Harness Location
F	Pitch Servo Wiring Harness Location

Task 14-23-01 – Cessna 180, 182-182D, 185 Autopilot Configuration

14.2.1. If your unit is being reinstalled into the aircraft it was removed from, and no corrective action has been performed on the unit, no further configuration is necessary. Operation check the unit per Task 04-24-01 in Section 4.1.

14.2.2. If the unit was not previously installed in the aircraft, or has been serviced, perform the following steps:

Configure Vizion Autopilot

The Vizion autopilot has the adjustable gain settings to fly nearly any aircraft in which it may be installed, therefore it is imperative that it be configured to properly fly the aircraft. Refer to the Vizion PMA Installation Guide Cessna 180, 182-182D, 185 Appendix F (255) for configuration settings and procedures.

Task 14-23-02 – Removal of Cessna 180, 182-182D, 185 Roll Servo

14.2.3. Shut down aircraft power and disconnect the aircraft battery.

14.2.4. Refer to the Vizion PMA Installation Guide Cessna 180, 182-182D, 185 Appendix F (255) for illustrated parts catalog.

14.2.5. Remove the inspection cover on the lower wing skin located forward of the inboard end of the aileron on the left wing.

14.2.6. Remove the AN3-7A bolt holding the pushrod to the roll servo arm.

14.2.7. Remove the (4) AN3-3A bolts, (4) MS35333-39 lock washers holding the roll servo (8100-064 or 8100-065).

14.2.8. Remove the roll servo from the aircraft and disconnect the roll servo wiring harness connector to the roll servo.

14.2.9. If the roll servo is being replaced immediately, proceed to step 4 of the roll servo installation instructions. If the servo is being removed for repair or service, the pushrod must be removed using the following steps.

14.2.10. Loosen one of the aileron cable turnbuckles to allow for easy removal and replacement of the bolt connecting the aileron cable to the bellcrank.

14.2.11. Remove the AN3-17A bolt from the left aileron bellcrank and replace with original hardware.

14.2.12. Remove the push rod assembly from the aileron bellcrank inspection hole.

14.2.13. Tension the aileron cable according to the aircraft service manual.

NOTE: Proper cable tension is essential for proper autopilot performance! Use a tensioner to verify cable tension.

14.2.14. Verify that aileron rigging is correct according to the aircraft service manual and adjust as needed.

14.2.15. Safety wire the aileron cable turnbuckle.

14.2.16. Secure wiring harness to prevent interference with flight controls.

14.2.17. Replace inspection covers.

14.2.18. Reconnect aircraft battery.

14.2.19. All parts should now be safely stored until needed for installation.

Task 14-23-03 – Installation of Cessna 180, 182-182D, 185 Roll Servo

14.2.20. Shut down aircraft power and disconnect the aircraft battery.

14.2.21. Refer to the Vizion PMA Installation Guide Cessna 180, 182-182D, 185 Appendix F (255) for illustrated parts catalog.

14.2.22. Remove the inspection cover on the lower wing skin located forward of the inboard end of the aileron on the left wing.

14.2.23. Attach the Cessna 172 Roll Servo Arm (P/N 7200-091) to the 60 inch/lb PMA servo (P/N 8100-064 for 12 volt or P/N 8100-065 for 24 volt) using the provided 8-32 x 3/8" flat head screws. Use blue threadlocker (Loctite 242 or equivalent) and torque the screws to 18-20 in-lb.

- 14.2.24. Connect the roll servo wiring harness connector to the roll servo.
- 14.2.25. Place the roll servo assembly in the wing and attach it to the Cessna 18X Upper Roll Bracket (P/N 1450-127) and Cessna 18X Lower Roll Bracket (1450-128) using 4 ea. AN3-3A bolts with MS35333-39 lock washers and blue threadlocker (Loctite242 or equivalent). The Cessna 172 Roll Servo Arm (P/N 7200-091) should be oriented upward between the servo stops.
- 14.2.26. Torque the 4 AN3-3A servo mounting bolts to 20-25 in-lb.
- 14.2.27. Remove the inspecting cover near the left aileron bellcrank. If the roll servo pushrod is still in the aircraft because the roll servo is being immediately replaced after removal, proceed to step 15. Otherwise, proceed to step 9.
- 14.2.28. Loosen one of the aileron cable turnbuckles to allow for easy removal and replacement of the bolt connecting the aileron cable to the bellcrank.
- 14.2.29. Remove the rear aileron cable bolt from the left aileron bellcrank and replace with hardware as shown below. Torque the AN-3 bolt to 20-25 in-lb.

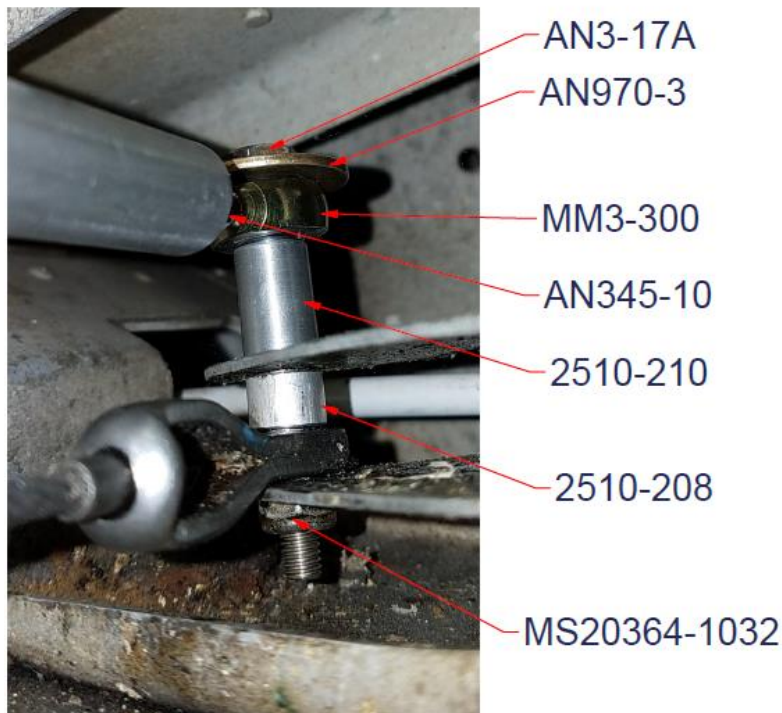

- 14.2.30. Tension the aileron cable according to the aircraft service manual.

NOTE: Proper cable tension is essential for proper autopilot performance! Use a tensiometer to verify cable tension.

- 14.2.31. Verify that aileron rigging is correct according to the aircraft service manual and adjust as needed.
- 14.2.32. Safety wire the aileron cable turnbuckle.

14.2.33. Fully thread an AN345-10 on a MM3-300 rod end bearing then partially thread the MM3-300 rod end bearing in one end of the 41" push rod (2520-062).

14.2.34. Insert the push rod assembly in the aileron bellcrank inspection hole with the rod end bearing going toward the roll servo.

14.2.35. Ensure that the aileron cable is not wrapped around the 41" push rod (2510-062) then partially thread the MM3-300 rod end attached to the aileron bellcrank in the outboard end of the push rod.

14.2.36. Have an assistant hold the yoke in the full right position and rotate the servo arm against the outboard stop on the roll servo bracket.

14.2.37. Thread the MM3-300 rod end bearing into the servo end of the pushrod until the pushrod is the correct length to align with the drive point on the servo arm.

14.2.38. Verify that the control cable is not twisted around the pushrod.

14.2.39. Attach the pushrod assembly to the Cessna 172 Roll Servo Arm (P/N 7200-091) as shown below and torque to 20-25 in-lb.

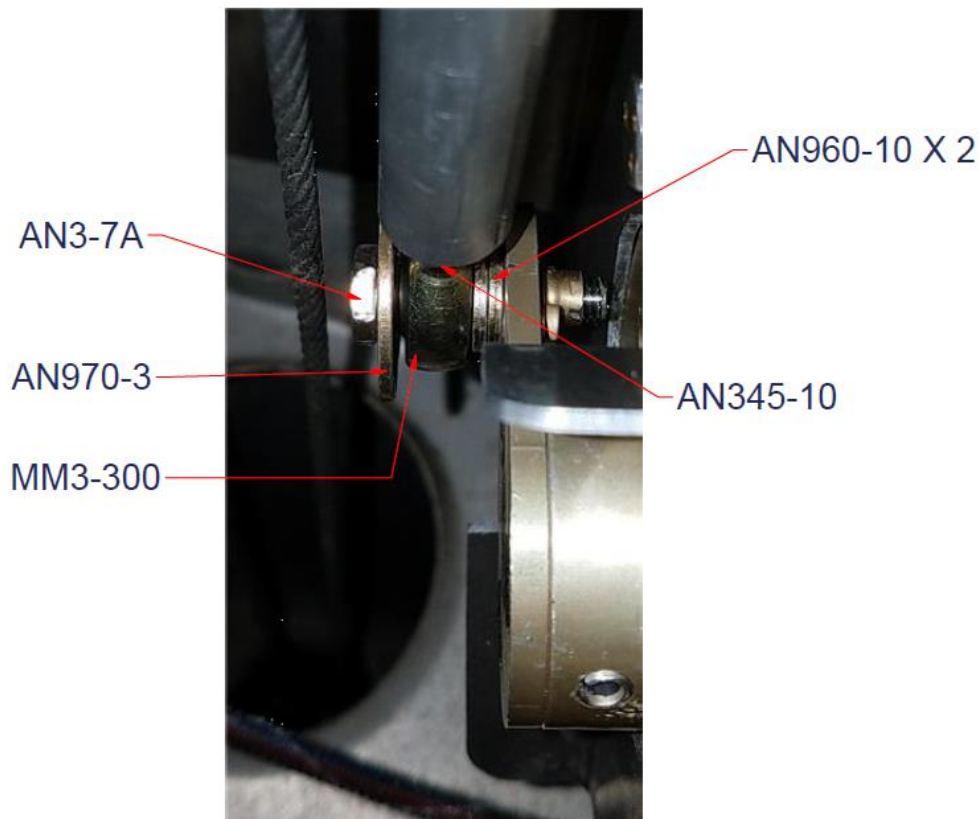

14.2.40. Apply blue threadlocker (Loctite242 or equivalent) to the threaded shank of both MM3-300 rod ends. Rotate the pushrod until the rod end bearings on each end are threaded in equally then tighten the jam nuts to 20-25 in-lb.

14.2.41. Move the yoke throughout the full range of travel and check for binding in the rod end bearings. If binding exists adjust the rod end bearings and jam nuts to eliminate it.

14.2.42. Ensure that aircraft stops are contacted prior to servo stops. Adjust length of pushrod as needed until servo stops are not contacted when controls are moved to both ends of travel.

14.2.43. Verify that the servo and pushrod motion are unobstructed throughout the full control travel. Ensure that the wiring harness is properly secured to prevent interference.

14.2.44. Apply torque seal to all bolts after final torquing is achieved.

Task 14-23-04 – Removal of Cessna 180, 182-182D, 185 Pitch Servo

14.2.45. Shut down aircraft power and disconnect the aircraft battery.

14.2.46. Refer to the Vizion PMA Installation Guide Cessna 180, 182-182D, 185 Appendix F (255) for illustrated parts catalog.

14.2.47. Remove the baggage compartment bulkhead to access the rear fuselage.

14.2.48. Disconnect 6 pin connector from the pitch servo.

14.2.49. Disconnect the 9 pin connector from the pitch servo.

14.2.50. Ensure that 9 pin connector / harness is adequately secured and will not interfere with aircraft controls.

14.2.51. Disconnect the AN3-10A bolt securing the servo arm to the link sensor.

14.2.52. Remove the 4 AN3-3A bolts securing the servo to the pitch bracket assembly.

14.2.53. If the pitch servo is being replaced immediately, proceed to step 4 of the pitch servo installation instructions. If the servo is being removed for repair or service, the pushrod must be removed using task 14-23-06.

Task 14-23-05 – Installation of Cessna 180, 182-182D, 185 Pitch Servo

14.2.54. Shut down aircraft power and disconnect the aircraft battery.

14.2.55. Refer to the Vizion PMA Installation Guide Cessna 180, 182-182D, 185 Appendix F (255) for illustrated parts catalog.

14.2.56. Remove the baggage compartment bulkhead to access the rear fuselage.

14.2.57. Install PMA Servo (P/N 8100-064 OR 8100-065) into the pitch bracket assembly using (4) AN3-3A bolts and (4) MS35333-39 lock washers. Prior to installation of the four (4) bolts, apply Loctite 242 or equivalent thread locker to the bolts. Tighten the bolts to 20-25 inch pounds.

14.2.58. Connect 6 pin connector to the pitch servo.

14.2.59. Connect the 9 pin connector to the pitch servo.

14.2.60. Ensure that 9 pin connector / harness is adequately secured and will not interfere with aircraft controls.

14.2.61. If the pitch servo was not replaced immediately, proceed to Task 14-23-06 to install the PMA Link Sensor (P/N 8000-177). Otherwise, proceed to step 9.

14.2.62. Attach the pushrod to the pitch servo arm with hardware as shown below and torque to 20-25 in-lb.

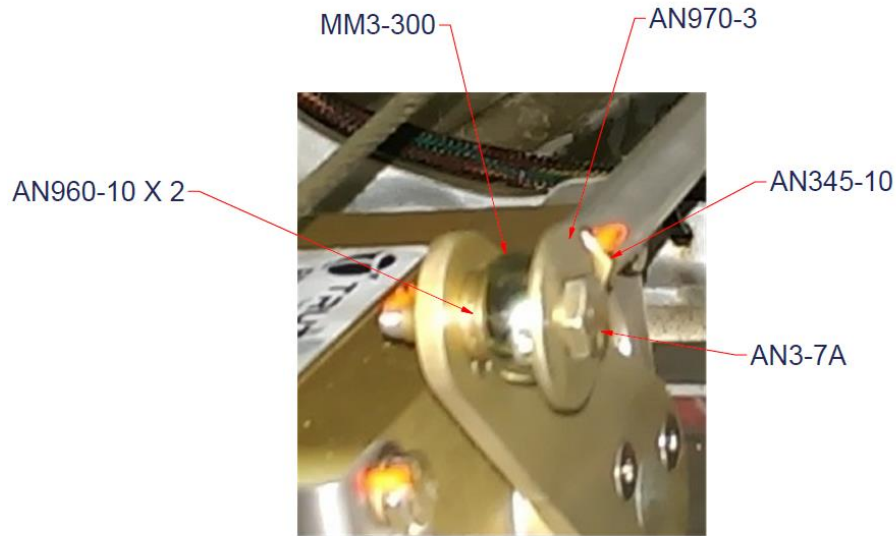

14.2.63. Move the yoke throughout the full range of travel and check for binding in the rod end bearings. If binding exists adjust the rod end bearings and jam nuts to eliminate it.

14.2.64. Ensure that aircraft stops are contacted prior to servo stops. Adjust length of pushrod as needed until servo stops are not contacted when controls are moved to both ends of travel.

14.2.65. Verify that the servo and pushrod motion are unobstructed throughout the full control travel. Ensure that the wiring harness is properly secured to prevent interference.

14.2.66. Apply torque seal to all bolts after final torquing is achieved.

Task 14-23-06 – Removal of Cessna 180, 182-182D, 185 Link Sensor

14.2.67. Shut down aircraft power and disconnect the aircraft battery.

14.2.68. Refer to the Vizion PMA Installation Guide Cessna 180, 182-182D, 185 Appendix F (255) for illustrated parts catalog.

14.2.69. Remove the baggage compartment bulkhead to access the rear fuselage.

14.2.70. Remove the rear inspection cover on the bottom of the fuselage.

- 14.2.71. Disconnect 6 pin connector from the pitch servo.
- 14.2.72. Loosen jam nut on link sensor and unthread it from the elevator bellcrank rod end bearing.
- 14.2.73. Remove jam nut from rod end bearing.
- 14.2.74. Remove the AN3 hardware from the pitch servo arm and remove the pushrod assembly with the link sensor cable.
- 14.2.75. If the link sensor is being replaced immediately, proceed to step 6 of Task 14-23-07. If the link sensor is being removed for repair or service move to the next step.
- 14.2.76. Disconnect the 9 pin connector from the pitch servo.
- 14.2.77. Secure the pitch servo arm so that it cannot interfere with aircraft controls.
- 14.2.78. Secure elevator bellcrank rod end bearing so that it cannot interfere with aircraft controls.
- 14.2.79. Replace the baggage compartment bulkhead.
- 14.2.80. Replace the rear inspection cover on the bottom of the fuselage.
- 14.2.81. Reconnect aircraft battery.
- 14.2.82. Parts should now be safely stored until needed for installation.

Task 14-23-07 – Installation of Cessna 180, 182-182D, 185 Link Sensor

- 14.2.83. Shut down aircraft power and disconnect the aircraft battery.
- 14.2.84. Refer to the Vizion PMA Installation Guide Cessna 180, 182-182D, 185 Appendix F (255) for illustrated parts catalog.
- 14.2.85. Remove the baggage compartment bulkhead to access the rear fuselage.
- 14.2.86. Remove the rear inspection cover on the bottom of the fuselage.
- 14.2.87. Install hardware on the elevator bellcrank as shown below.

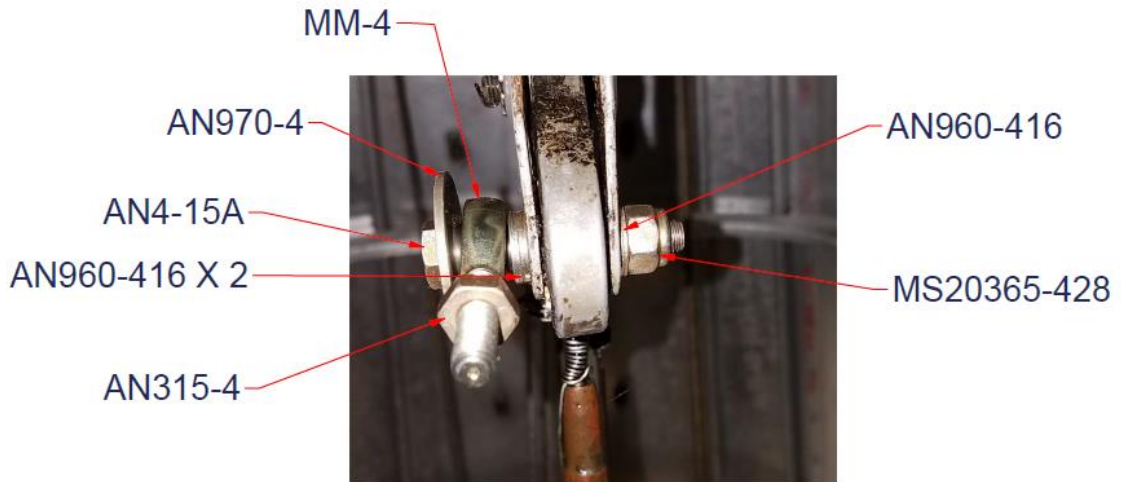

14.2.88. Partially thread the link sensor end of the Late 182 Pitch Push Rod (7200-111) in the MM-4 rod end attached to the elevator bellcrank.

14.2.89. Fully thread an AN345-10 nut on a MM3-300 rod end then partially thread the MM3-300 rod end into the forward end of the Late 182 Pitch Push Rod (7200-111).

14.2.90. Have an assistant hold the yoke in the full aft position and rotate the servo arm against the aft stop on the pitch servo bracket.

14.2.91. Thread the MM-3-300 rod end bearing into the servo end of the pushrod until the pushrod is the correct length to align with the drive point on the servo arm.

14.2.92. Attach the pushrod to the pitch servo arm with hardware as shown below and torque to 20-25 in-lb.

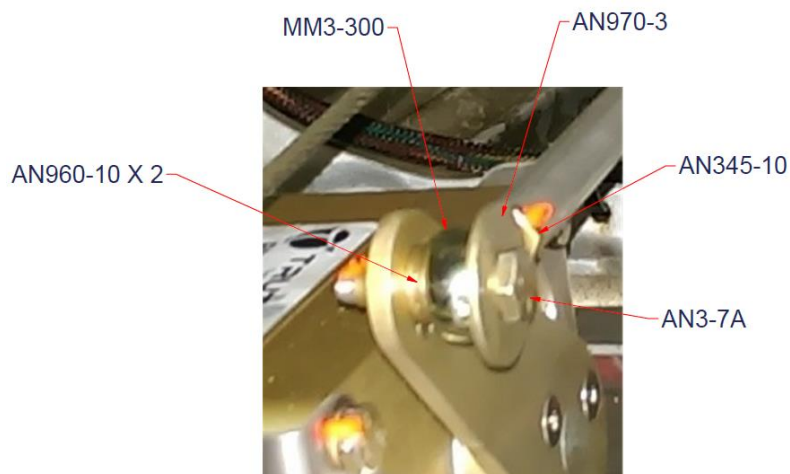

14.2.93. Apply blue threadlocker (Loctite242 or equivalent) to the threaded shank of both rod ends. Rotate the pushrod until the rod end bearings on each

end are threaded in equally and the link sensor connector is pointed directly down then tighten the jam nuts to 20-25 in-lb.

14.2.94. Move the yoke throughout the full range of travel and check for binding in the rod end bearings. If binding exists adjust the rod end bearings and jam nuts to eliminate it.

14.2.95. Ensure that aircraft stops are contacted prior to servo stops. Adjust length of pushrod as needed until servo stops are not contacted when controls are moved to both ends of travel.

14.2.96. Connect the 9 pin pitch servo wiring harness to the pitch servo.

14.2.97. Attach the 6 pin link sensor cable to the link sensor.

14.2.98. Attach the 6 pin link sensor cable to the pitch servo.

14.2.99. Ensure the link sensor cable is secured in a fashion that does not place excess strain on the connection to the link sensor and also prevents interference with the aircraft controls.

14.2.100. Replace the baggage compartment bulkhead.

14.2.101. Replace the rear inspection cover on the bottom of the fuselage.

14.2.102. Reconnect aircraft battery.

14.2.103. Perform Task 04-24-01, Task 04-24-06, and Task 04-24-07.

15. Appendix F – Cessna 182E-182T

15.1. Cessna 182E-182T Additional Installation Components

PART NUMBER	DESCRIPTION
7200-091	C172 Roll Servo Arm
2520-062	41" Push Rod .5" OD Tapped 10-32
2510-073	.250 L X .375 OD X .199 ID Aluminum Spacer
1450-128	18X Lower Roll Bracket
1450-127	18X Upper Roll Bracket
7200-111	Late Model 182 Pitch Push Rod
7200-110	Late Model 182 Pitch Tray Assembly
7200-106	2.75" PMA Servo Arm Assembly
1450-130	Late 182 Pitch Bracket

15.2. Cessna 182E-182T Equipment Locations

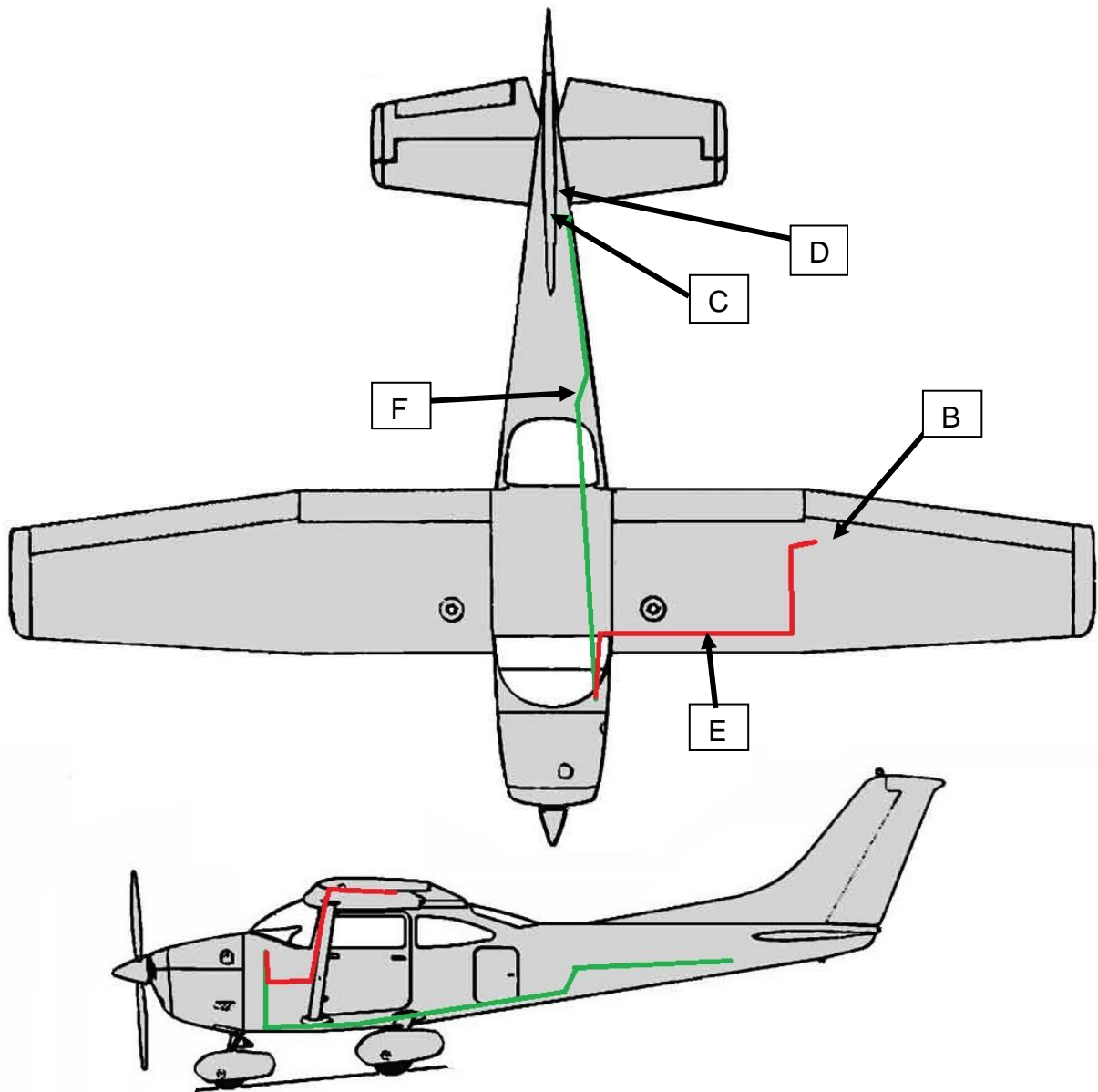

The above locations are general guidance. Actual equipment locations may vary per aircraft.

Wiring harness routing: The roll harness routing is shown in red by line E. This portion passes to the right side of the aircraft and through the spar to the roll servo. The pitch harness routing is shown in green by line F. This portion passes to the right side of the aircraft and through the spar to the pitch servo.

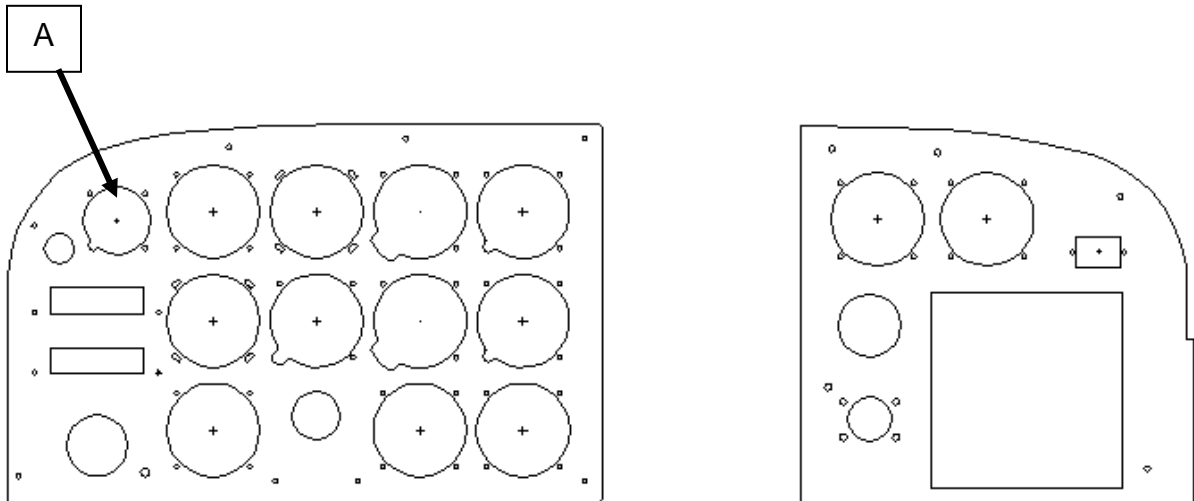

LRU Definitions

A	Vizion Autopilot
B	12 Volt Roll Servo (8100-064) OR 24 Volt Roll Servo (8100-065)
C	12 Volt Pitch Servo (8100-064) OR 24 Volt Pitch Servo (8100-065)
D	Link Sensor (8000-177)
E	Roll Servo Wiring Harness Location
F	Pitch Servo Wiring Harness Location

15.3. Task 14-23-01 – Cessna 182E-182T Autopilot Configuration

15.3.1. If your unit is being reinstalled into the aircraft it was removed from, and no corrective action has been performed on the unit, no further configuration is necessary. Operation check the unit per Task 04-24-01 in Section 4.1.

15.3.2. If the unit was not previously installed in the aircraft, or has been serviced, perform the following steps:

Configure Vizion Autopilot

The Vizion autopilot has the adjustable gain settings to fly nearly any aircraft in which it may be installed, therefore it is imperative that it be configured to properly fly the aircraft. Refer to the Vizion PMA Installation Guide Cessna 182E-182T Appendix F (256) for configuration settings and procedures.

15.4. Task 15-23-02 – Removal of Cessna 182E-182T Roll Servo

15.4.1. Shut down aircraft power and disconnect the aircraft battery.

15.4.2. Refer to the Vizion PMA Installation Guide Cessna 182E-182T Appendix F (256) for illustrated parts catalog.

15.4.3. Remove the inspection cover on the lower wing skin located forward of the inboard end of the aileron on the left wing.

15.4.4. Remove the AN3-10A bolt holding the pushrod to the roll servo arm.

15.4.5. Remove the (4) AN3-3A bolts, (4) MS35333-39 lock washers holding the roll servo (8100-064 or 8100-065).

15.4.6. Remove the roll servo from the aircraft and disconnect the roll servo wiring harness connector to the roll servo.

15.4.7. If the roll servo is being replaced immediately, proceed to step 4 of the roll servo installation instructions. If the servo is being removed for repair or service, the pushrod must be removed using the following steps.

15.4.8. Loosen one of the aileron cable turnbuckles to allow for easy removal and replacement of the bolt connecting the aileron cable to the bellcrank.

15.4.9. Remove the AN3-14A bolt from the left aileron bellcrank and replace with original hardware.

15.4.10. Remove the push rod assembly from the aileron bellcrank inspection hole.

15.4.11. Tension the aileron cable according to the aircraft service manual.

NOTE: Proper cable tension is essential for proper autopilot performance! Use a tensiometer to verify cable tension.

15.4.12. Verify that aileron rigging is correct according to the aircraft service manual and adjust as needed.

15.4.13. Safety wire the aileron cable turnbuckle.

15.4.14. Secure wiring harness to prevent interference with flight controls.

15.4.15. Replace inspection covers.

15.4.16. Reconnect aircraft battery.

15.4.17. All parts should now be safely stored until needed for installation.

15.5. Task 15-23-03 – Installation of Cessna 182E-182T Roll Servo

15.5.1. Shut down aircraft power and disconnect the aircraft battery.

15.5.2. Refer to the Vizion PMA Installation Guide Cessna 182E-182T Appendix F (256) for illustrated parts catalog.

15.5.3. Remove the inspection cover on the lower wing skin located forward of the inboard end of the aileron on the left wing.

15.5.4. Attach the Cessna 172 Roll Servo Arm (P/N 7200-091) to the 60 inch/lb PMA servo (P/N 8100-064 for 12 volt or P/N 8100-065 for 24 volt) using the

provided 8-32 x 3/8" flat head screws. Use blue threadlocker (Loctite 242 or equivalent) and torque the screws to 18-20 in-lb.

15.5.5. Connect the roll servo wiring harness connector to the roll servo.

15.5.6. Place the roll servo assembly in the wing and attach it to the Cessna 18X Upper Roll Bracket (P/N 1450-127) and Cessna 18X Lower Roll Bracket (1450-128) using 4 ea. AN3-3A bolts with MS35333-39 lock washers and blue threadlocker (Loctite242 or equivalent). The Cessna 172 Roll Servo Arm (P/N 7200-091) should be oriented upward between the servo stops.

15.5.7. Torque the 4 AN3-3A servo mounting bolts to 20-25 in-lb.

15.5.8. Remove the inspecting cover near the left aileron bellcrank. If the roll servo pushrod is still in the aircraft because the roll servo is being immediately replaced after removal, proceed to step 15. Otherwise, proceed to step 9.

15.5.9. Loosen one of the aileron cable turnbuckles to allow for easy removal and replacement of the bolt connecting the aileron cable to the bellcrank.

15.5.10. Remove the rear aileron cable bolt from the left aileron bellcrank and replace with hardware as shown below. Torque the AN-3 bolt to 20-25 in-lb.

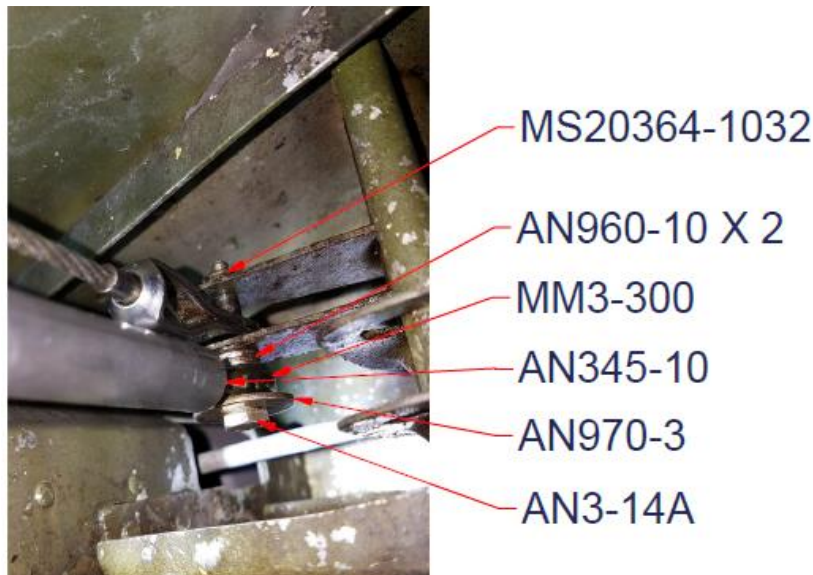

15.5.11. Tension the aileron cable according to the aircraft service manual.

NOTE: Proper cable tension is essential for proper autopilot performance! Use a tensiometer to verify cable tension.

15.5.12. Verify that aileron rigging is correct according to the aircraft service manual and adjust as needed.

15.5.13. Safety wire the aileron cable turnbuckle.

15.5.14. Fully thread an AN345-10 on a MM3-300 rod end bearing then partially thread the MM3-300 rod end bearing in one end of the 41" push rod (2520-062).

15.5.15. Insert the push rod assembly in the aileron bellcrank inspection hole with the rod end bearing going toward the roll servo.

15.5.16. Ensure that the aileron cable is not wrapped around the 41" push rod (2510-062) then partially thread the MM3-300 rod end attached to the aileron bellcrank in the outboard end of the push rod.

15.5.17. Have an assistant hold the yoke in the full right position and rotate the servo arm against the outboard stop on the roll servo bracket.

15.5.18. Thread the MM-3-300 rod end bearing into the servo end of the pushrod until the pushrod is the correct length to align with the drive point on the servo arm.

15.5.19. Verify that the control cable is not twisted around the pushrod.

15.5.20. Attach the pushrod assembly to the Cessna 172 Roll Servo Arm (P/N 7200-091) as shown below and torque to 20-25 in-lb.

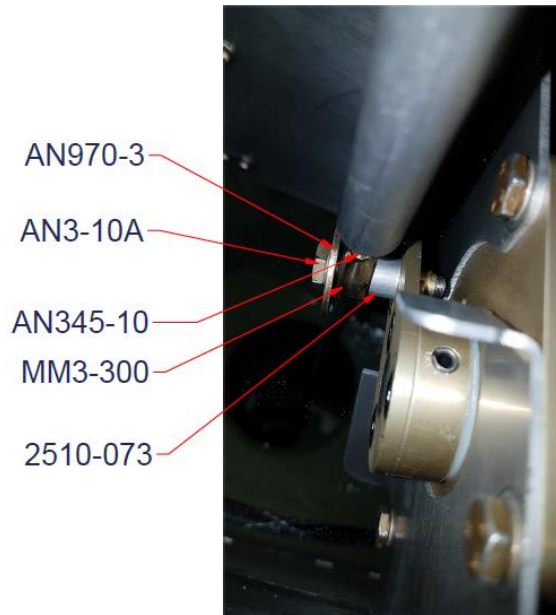

15.5.21. Apply blue threadlocker (Loctite242 or equivalent) to the threaded shank of both MM3-300 rod ends. Rotate the pushrod until the rod end bearings on each end are threaded in equally then tighten the jam nuts to 20-25 in-lb.

15.5.22. Move the yoke throughout the full range of travel and check for binding in the rod end bearings. If binding exists adjust the rod end bearings and jam nuts to eliminate it.

15.5.23. Ensure that aircraft stops are contacted prior to servo stops. Adjust length of pushrod as needed until servo stops are not contacted when controls are moved to both ends of travel.

15.5.24. Verify that the servo and pushrod motion are unobstructed throughout the full control travel. Ensure that the wiring harness is properly secured to prevent interference.

15.5.25. **Apply torque seal to all bolts after final torquing is achieved.**

15.6. Task 15-23-04 – Removal of Cessna 182E-182T Pitch Servo

15.6.1. Shut down aircraft power and disconnect the aircraft battery.

15.6.2. Refer to the Vizion PMA Installation Guide Cessna 182E-182T Appendix F (256) for illustrated parts catalog.

15.6.3. Remove the baggage compartment bulkhead to access the rear fuselage.

15.6.4. Disconnect 6 pin connector from the pitch servo.

15.6.5. Disconnect the 9 pin connector from the pitch servo.

15.6.6. Ensure that 9 pin connector / harness is adequately secured and will not interfere with aircraft controls.

15.6.7. Disconnect the AN3-10A bolt securing the servo arm to the link sensor.

15.6.8. Remove the 4 AN3-3A bolts securing the servo to the pitch bracket assembly.

15.6.9. If the pitch servo is being replaced immediately, proceed to step 4 of the pitch servo installation instructions. If the servo is being removed for repair or service, the pushrod must be removed using task 14-23-06.

15.7. Task 15-23-05 – Installation of Cessna 182E-182T Pitch Servo

15.7.1. Shut down aircraft power and disconnect the aircraft battery.

15.7.2. Refer to the Vizion PMA Installation Guide Cessna 182E-182T Appendix F (256) for illustrated parts catalog.

15.7.3. Remove the baggage compartment bulkhead to access the rear fuselage.

15.7.4. Install PMA Servo (P/N 8100-064 OR 8100-065) into the pitch bracket assembly using (4) AN3-3A bolts and (4) MS35333-39 lock washers. Prior to installation of the four (4) bolts, apply Loctite 242 or equivalent thread locker to the bolts. Tighten the bolts to 20-25 inch pounds.

15.7.5. Connect 6 pin connector to the pitch servo.

15.7.6. Connect the 9 pin connector to the pitch servo.

15.7.7. Ensure that 9 pin connector / harness is adequately secured and will not interfere with aircraft controls.

15.7.8. If the pitch servo was not replaced immediately, proceed to Task 15-23-06 to install the PMA Link Sensor (P/N 8000-177). Otherwise, proceed to step 9.

15.7.9. Attach the pushrod to the pitch servo arm with hardware as shown below and torque to 20-25 in-lb.

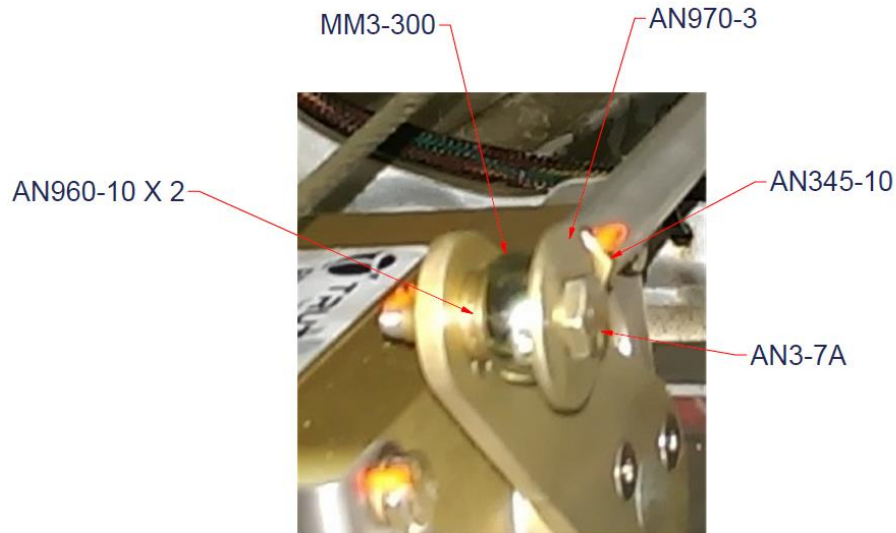

15.7.10. Move the yoke throughout the full range of travel and check for binding in the rod end bearings. If binding exists adjust the rod end bearings and jam nuts to eliminate it.

15.7.11. Ensure that aircraft stops are contacted prior to servo stops. Adjust length of pushrod as needed until servo stops are not contacted when controls are moved to both ends of travel.

15.7.12. Verify that the servo and pushrod motion are unobstructed throughout the full control travel. Ensure that the wiring harness is properly secured to prevent interference.

15.7.13. Apply torque seal to all bolts after final torquing is achieved.

15.8. Task 15-23-06 – Removal of Cessna 182E-182T Link Sensor

15.8.1. Shut down aircraft power and disconnect the aircraft battery.

15.8.2. Refer to the Vizion PMA Installation Guide Cessna 182E-182T Appendix F (256) for illustrated parts catalog.

15.8.3. Remove the baggage compartment bulkhead to access the rear fuselage.

15.8.4. Remove the rear inspection cover on the bottom of the fuselage.

15.8.5. Disconnect 6 pin connector from the pitch servo.

15.8.6. Loosen jam nut on link sensor and unthread it from the elevator bellcrank rod end bearing.

15.8.7. Remove jam nut from rod end bearing.

- 15.8.8. Remove the AN3 hardware from the pitch servo arm and remove the pushrod assembly with the link sensor cable.
- 15.8.9. If the link sensor is being replaced immediately, proceed to step 6 of Task 15-23-07. If the link sensor is being removed for repair or service move to the next step.
- 15.8.10. Disconnect the 9 pin connector from the pitch servo.
- 15.8.11. Secure the pitch servo arm so that it cannot interfere with aircraft controls.
- 15.8.12. Secure elevator bellcrank rod end bearing so that it cannot interfere with aircraft controls.
- 15.8.13. Replace the baggage compartment bulkhead.
- 15.8.14. Replace the rear inspection cover on the bottom of the fuselage.
- 15.8.15. Reconnect aircraft battery.
- 15.8.16. Parts should now be safely stored until needed for installation.

15.9. Task 15-23-07 – Installation of Cessna 182E-182T Link Sensor

- 15.9.1. Shut down aircraft power and disconnect the aircraft battery.
- 15.9.2. Refer to the Vizion PMA Installation Guide Cessna 182E-182T Appendix F (256) for illustrated parts catalog.
- 15.9.3. Remove the baggage compartment bulkhead to access the rear fuselage.
- 15.9.4. Remove the rear inspection cover on the bottom of the fuselage.
- 15.9.5. Install hardware on the elevator bellcrank as shown below.

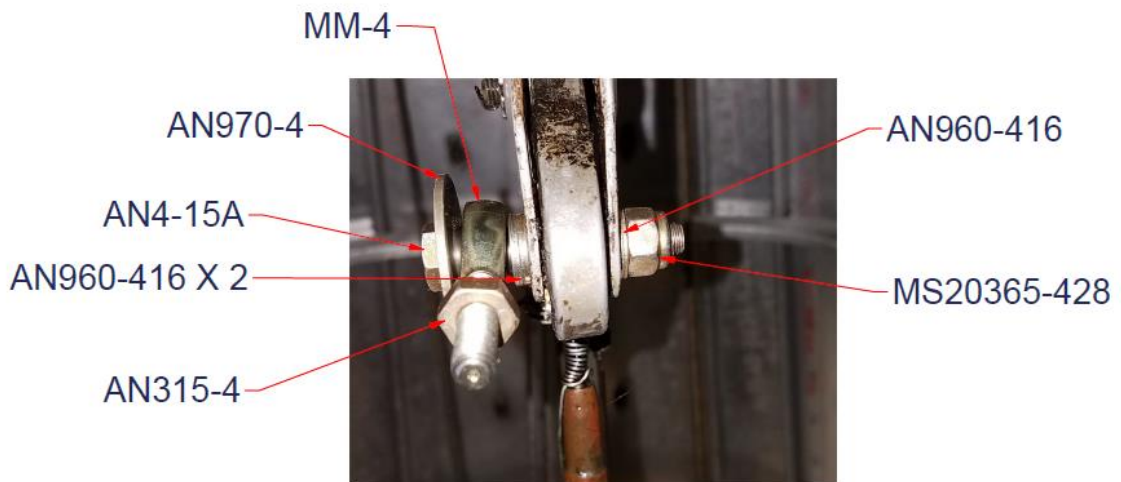

- 15.9.6. Partially thread the link sensor end of the Late 182 Pitch Push Rod (7200-111) in the MM-4 rod end attached to the elevator bellcrank.

15.9.7. Fully thread an AN345-10 nut on a MM3-300 rod end then partially thread the MM3-300 rod end into the forward end of the Late 182 Pitch Push Rod (7200-111).

15.9.8. Have an assistant hold the yoke in the full aft position and rotate the servo arm against the aft stop on the pitch servo bracket.

15.9.9. Thread the MM3-300 rod end bearing into the servo end of the pushrod until the pushrod is the correct length to align with the drive point on the servo arm.

15.9.10. Attach the pushrod to the pitch servo arm with hardware as shown below and torque to 20-25 in-lb.

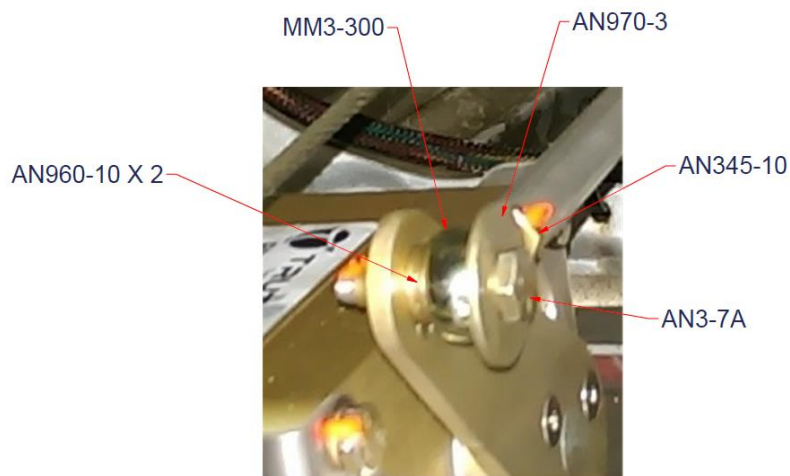

15.9.11. Apply blue threadlocker (Loctite242 or equivalent) to the threaded shank of both rod ends. Rotate the pushrod until the rod end bearings on each end are threaded in equally and the link sensor connector is pointed directly down then tighten the jam nuts to 20-25 in-lb.

15.9.12. Move the yoke throughout the full range of travel and check for binding in the rod end bearings. If binding exists adjust the rod end bearings and jam nuts to eliminate it.

15.9.13. Ensure that aircraft stops are contacted prior to servo stops. Adjust length of pushrod as needed until servo stops are not contacted when controls are moved to both ends of travel.

15.9.14. Connect the 9 pin pitch servo wiring harness to the pitch servo.

15.9.15. Attach the 6 pin link sensor cable to the link sensor.

15.9.16. Attach the 6 pin link sensor cable to the pitch servo.

15.9.17. Ensure the link sensor cable is secured in a fashion that does not place excess strain on the connection to the link sensor and also prevents interference with the aircraft controls.

15.9.18. Replace the baggage compartment bulkhead.

15.9.19. Replace the rear inspection cover on the bottom of the fuselage.

15.9.20. Reconnect aircraft battery.

15.9.21. Perform Task 04-24-01, Task 04-24-06, and Task 04-24-07.

16. Appendix G – Piper PA-32

16.1. Piper PA-32 Additional Installation Components

1420-229	PMA Cable Clamp Half Countersunk
1420-230	PMA Cable Clamp Half Plain
2520-010	6" Push Rod
2520-013	8" Push Rod
7200-096	2.5" PMA Servo Arm Assembly
7200-097	2" PMA Servo Arm Assembly
7200-108	PA-28 Roll Bracket Assembly
7200-103	PA-28 Pitch Bracket Assembly
7200-104	PA-28 Bellcrank

16.2. PA-32 Equipment Locations

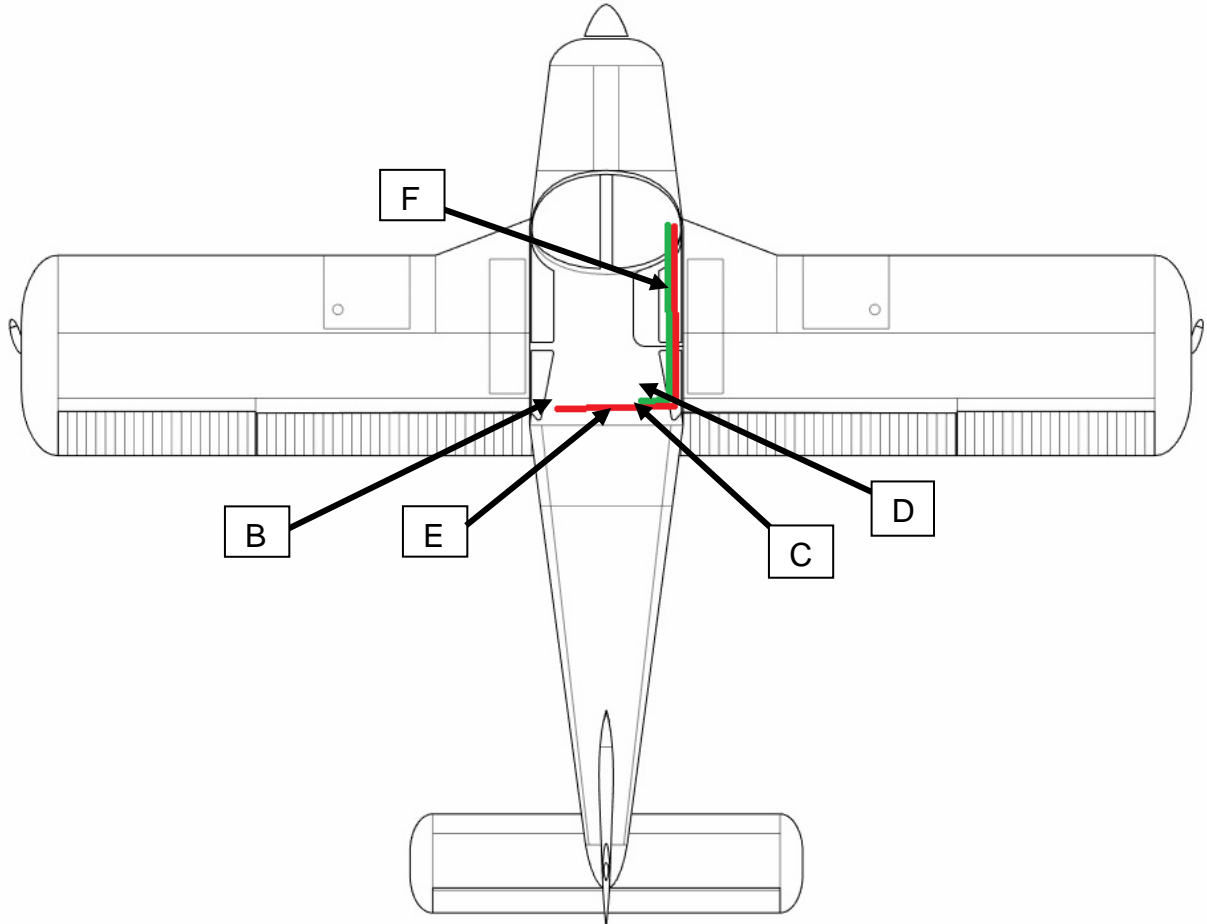

The above locations are general guidance. Actual equipment locations may vary per aircraft.

Wiring harness routing: The roll harness routing is shown in red by line E. This portion passes to the right side of the aircraft and through the spar to the roll servo. The pitch harness routing is shown in green by line F. This portion passes to the right side of the aircraft and through the spar to the pitch servo.

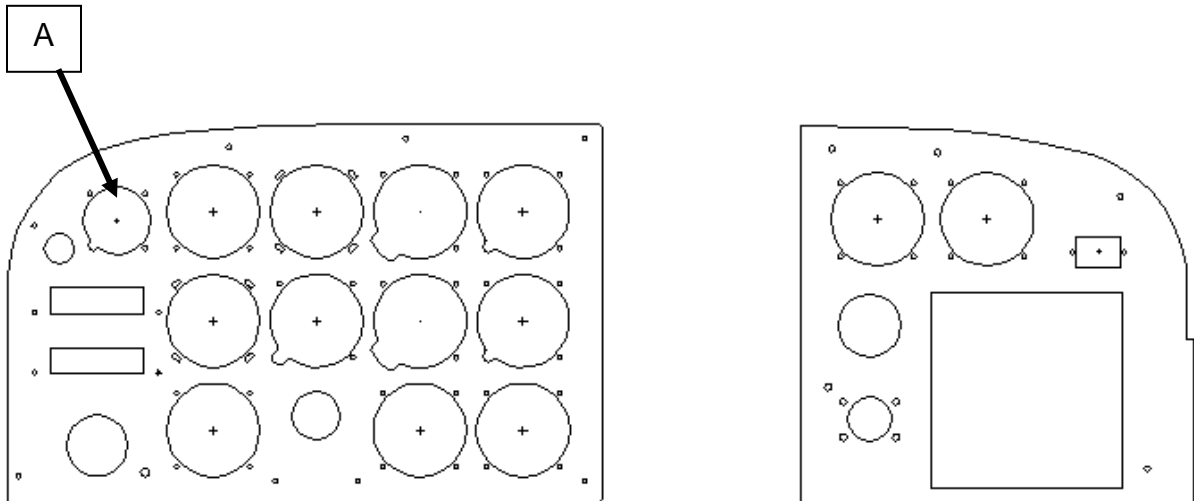

LRU Definitions

A	Vizion Autopilot
B	12 Volt Roll Servo (8100-064) OR 24 Volt Roll Servo (8100-065)
C	12 Volt Pitch Servo (8100-078) OR 24 Volt Pitch Servo (8100-079)
D	Link Sensor (8000-177)
E	Roll Servo Wiring Harness Location
F	Pitch Servo Wiring Harness Location

16.3. Task 16-23-01 – Piper PA-32 Autopilot Configuration

16.3.1. If your unit is being reinstalled into the aircraft it was removed from, and no corrective action has been performed on the unit, no further configuration is necessary. Operation check the unit per Task 04-24-01 in Section 4.1.

16.3.2. If the unit was not previously installed in the aircraft, or has been serviced, perform the following steps:

Configure Vizion Autopilot

The Vizion autopilot has the adjustable gain settings to fly nearly any aircraft in which it may be installed, therefore it is imperative that it be configured to properly fly the aircraft. Refer to the Vizion PMA Installation Guide PA-32 Appendix G (267) for configuration settings and procedures.

16.4. Task 16-23-02 – Removal of Piper PA-32 Roll Servo

16.4.1. Shut down aircraft power and disconnect the aircraft battery.

- 16.4.2. Refer to the Vizion PMA Installation Guide PA-32 Appendix G (267) for illustrated parts catalog.
- 16.4.3. The roll servo (8100-064 or 8100-065) is located under the rear seat on the left side of the aircraft.
- 16.4.4. Remove the rear seat.
- 16.4.5. Remove the electrical connector from the back of the servo.
- 16.4.6. Remove the 2 cable clamp assemblies (6 AN3-5A bolts) holding the bridal cable to the primary aileron control cable.
- 16.4.7. Remove the four (2) AN3-3A bolts, (2) 10-32 x 3/8 Socket Head Cap Screws, and four (4) MS35333-39 lock washers holding the roll servo (8100-064 or 8100-065) to the roll servo bracket assembly.
- 16.4.8. Remove the AN4-6A bolt securing the PA-32 bellcrank (7200-108) to the PA-28 roll bracket assembly (7200-102).
- 16.4.9. Remove the (6) AN526C832R10 screws and MS20361-832 nuts securing the roll bracket assembly to the aircraft.
- 16.4.10. Remove the roll bracket assembly and roll servo with bridal cable attached from the aircraft.
- 16.4.11. If the roll servo is being replaced immediately, proceed to step 6 of the roll servo installation instructions. If the servo is being removed for repair or service, the PA-28 roll bracket assembly must be using the following steps.
- 16.4.12. Replace the AN3-10A bolt from the aileron cable clamp with an appropriate length AN3 bolt and torque to 20-25 in-lb.
- 16.4.13. Replace the roll bracket assembly using (6) AN526C832R10 screws and MS20361-832 nuts. Torque to 18-20 in-lb.
- 16.4.14. Reconnect the PA-32 bellcrank to the roll servo bracket using an AN4-6A bolt with Loctite 242 or equivalent threadlocker and torque to 50-70 in-lb.
- 16.4.15. Secure wiring harness to prevent interference with flight controls.
- 16.4.16. Replace the rear seat.
- 16.4.17. Reconnect aircraft battery.
- 16.4.18. All parts should now be safely stored until needed for installation.

16.5. Task 16-23-03 – Installation of Piper PA-32 Roll Servo

- 16.5.1. Shut down aircraft power and disconnect the aircraft battery.
- 16.5.2. Refer to the Vizion PMA Installation Guide PA-32 Appendix G (267) for illustrated parts catalog.
- 16.5.3. Remove the rear seat.

16.5.4. Remove the AN4-6A bolt securing the PA-32 bellcrank (7200-108) to the PA-28 roll bracket assembly (7200-102).

16.5.5. Remove the (6) AN526C832R10 screws and MS20361-832 nuts securing the roll bracket assembly to the aircraft.

16.5.6. Place the roll servo under the flap tube and attach to the PA-28 roll bracket assembly using two AN3-3A bolts in the upper holes and two 10-32 x 3/8 socket head cap screws in the lower holes. Place MS35333-39 lock washers under all of the bolts and apply Loctite 242 or equivalent to all bolts. Torque to 20-25 in-lb.

16.5.7. Install roll servo 9 pin connector from wiring harness to roll servo.

16.5.8. Attach the roll servo bracket to the aircraft using (6) AN526C832R10 screws and MS20361-832 nuts. Torque to 18-20 in-lb.

16.5.9. Reconnect the PA-32 bellcrank to the roll servo bracket using an AN4-6A bolt. Use Loctite 242 or equivalent threadlocker and torque to 50-70 in-lb.

16.5.10. Loosely assemble 2 cable clamps as shown below.

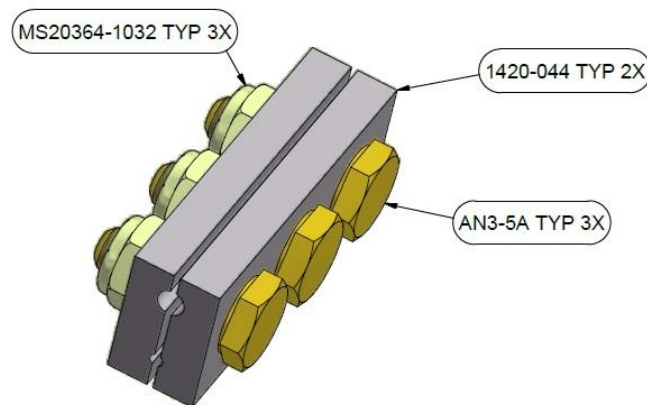

16.5.11. Clean the primary aileron control cable on the left side of the fuselage. The clamping areas must be free of dirt, oil and grease.

16.5.12. Place the cable clamps on the primary aileron control cable in the area shown below. Note that the large groove in the clamps will capture the primary aileron control cable. The small groove will capture the bridle cable.



16.5.13. The bridle cable will be routed as shown below. It is important that the bridle cable routing is as close to parallel with the primary aileron control cable as possible.



16.5.14. Determine which set of pulley holes on the roll bracket assembly (P/N 7200-102) will best locate the bridle cable parallel to the primary aileron control cable. Use a permanent marker to circle the holes to be used.

16.5.15. Attach the MS20219-2 pulleys to the circled holes in the roll bracket assembly (P/N 7200-102) as shown below. Torque AN4 bolts to 50-70 in-lb.

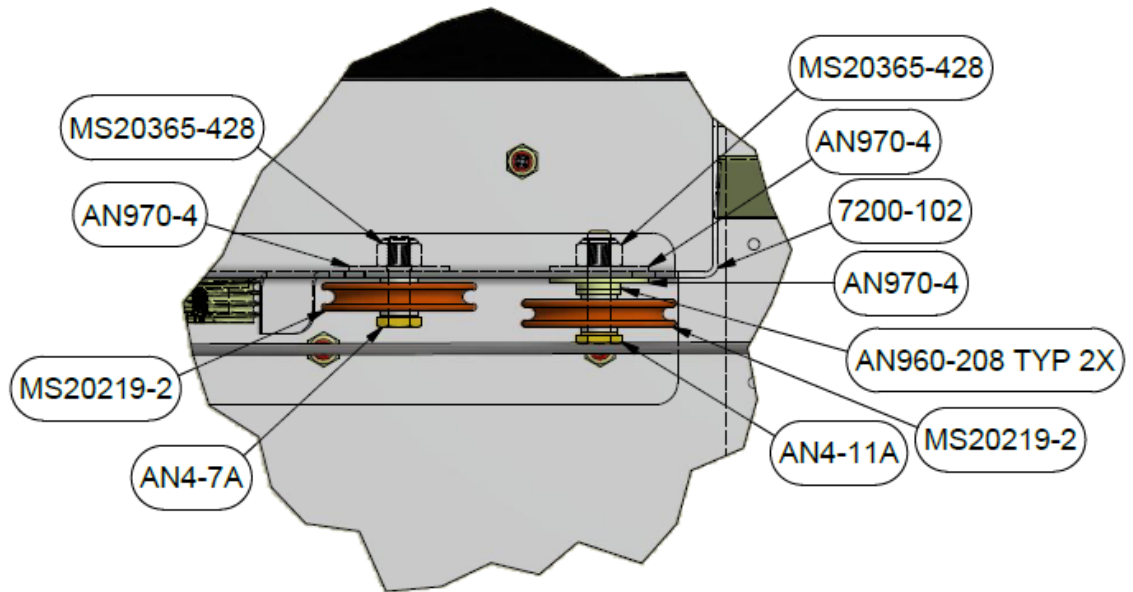

16.5.16. Hold the controls so that the primary aileron control cable is deflected fully to the left side of the aircraft. Slide the outboard cable clamp as far outboard as possible without the possibility interference with other aircraft components. Use a permanent marker to mark the primary aileron control cable at the outboard edge of the cable clamp.

16.5.17. Continue holding the aileron controls at full deflection and slide the inboard cable clamp as far outboard as possible until contacting the inboard pulley on the roll servo bracket. Use a permanent marker to mark the primary aileron control cable at the outboard edge of the cable clamp.

16.5.18. Fully deflect and hold the aileron controls in the opposite direction. Slide the outboard cable clamp as far inboard as possible until contacting the outboard pulley on the roll servo bracket. Use a permanent marker to mark the primary aileron control cable at the inboard edge of the cable clamp.

16.5.19. Continue holding the aileron controls at full deflection and slide the inboard cable clamp as far inboard as possible without the possibility

interference with other aircraft components. Use a permanent marker to mark the primary aileron control cable at the inboard edge of the cable clamp.

16.5.20. Center and hold the aileron controls.

16.5.21. The pin on the PA-32 Bridle Cable (P/N 7200-113) is located offset from the center of the cable. Orient the cable so that the longer side will be directed outboard as shown below.

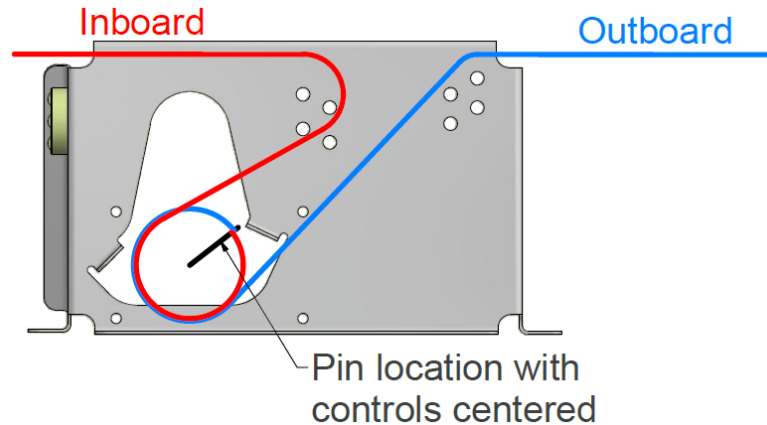

16.5.22. Place the pin on the PA-32 Bridle Cable (P/N 7200-113) in the hole on the circumference of the PMA Capstan Wheel (P/N 1420-233). Lightly tap the pin into the capstan so that the cable is fully seated in the groove of the capstan.

16.5.23. Route the PA-32 Bridle Cable (P/N 7200-113) as shown below. The capstan should have approximately 1-½ wraps of cable.



16.5.24. Position and hold the capstan so that the bridle cable pin is approximately centered between the points where the cable exits the capstan.

16.5.25. Place the outboard end on the bridle cable in the small groove of the outboard cable clamp leaving a ¼" gap between the stop ball and the cable clamp. Tighten the center bolt of the outboard cable clamp so that the cables are lightly clamped in place. Final torqueing will occur later.

16.5.26. Place the inboard end of the bridle cable in the small groove of the inboard cable clamp leaving a ¼" gap between the stop ball and the cable clamp.

Tension the cable by hand and tighten the center bolt of the outboard cable clamp so that the cables are lightly clamped in place.

16.5.27. Verify that the cable clamps are no closer than 3/8" to the marks made on the primary aileron control cable in the previous steps. If the clamps are closer than 3/8" recheck the aileron travel and contact Trutrak before proceeding with the installation.

16.5.28. Torque the AN3 bolts on the outer cable clamp to 35-40 in-lbs.

16.5.29. Bridle cable tension will be set to 0 to 3 pounds less than the primary aileron control cable tension

16.5.30. While holding the controls in place pull the inboard stop ball on the PA-32 Bridle Cable (P/N 7200-113) to tension the bridle cable. Torque one of the inboard cable clamp bolts to 35-40 in-lbs. Check that bridle cable tension is set correctly and repeat if needed.

16.5.31. Torque the AN3 bolts on the inboard cable clamp to 35-40 in-lbs.

16.5.32. Apply torque seal to both cable clamps at the 4 cable entrance locations.

16.5.33. Verify that full control travel is not impeded by the roll servo.

16.5.34. Verify that the wiring harness is properly secured and will not interfere with the aircraft controls.

16.5.35. Replace the rear seat.

16.5.36. Reconnect aircraft battery.

16.5.37. Perform Task 04-24-01 and Task 04-24-05.

16.6. Task 16-23-04 – Removal of Piper PA-32 Pitch Servo

16.6.1. Shut down aircraft power and disconnect the aircraft battery.

16.6.2. Refer to the Vizion PMA Installation Guide PA-32 Appendix G (267) for illustrated parts catalog.

16.6.3. The pitch servo (8100-078 or 8100-079) is located under the rear seat on the right side of the aircraft.

16.6.4. Remove the rear seat.

16.6.5. Disconnect 6 pin connector from the pitch servo.

16.6.6. Disconnect the 9 pin connector from the pitch servo.

16.6.7. Ensure that 9 pin connector / harness is adequately secured and will not interfere with aircraft controls.

16.6.8. Disconnect the AN3-10A bolt securing the servo arm to the link sensor.

16.6.9. Remove the 4 AN3-3A bolts securing the servo to the pitch bracket assembly.

16.6.10. If the pitch servo is being replaced immediately, proceed to step 5 of the pitch servo installation instructions. If the pitch servo is not going to be

replaced immediately safely store all parts until needed for installation and perform Task 16-23-06 to remove the PMA Link Sensor (P/N 8000-177).

16.7. Task 16-23-05 – Installation of Piper PA-32 Pitch Servo

- 16.7.1. Shut down aircraft power and disconnect the aircraft battery.
- 16.7.2. Refer to the Vizion PMA Installation Guide PA-32 Appendix G (267) for illustrated parts catalog.
- 16.7.3. The pitch servo (8100-078 or 8100-079) is located under the rear seat on the right side of the aircraft.
- 16.7.4. Remove the rear seat.
- 16.7.5. Install PMA Servo (P/N 8100-078 or 8100-079) into the PA-28 pitch bracket assembly (P/N 7200-103) using (4) AN3-3A bolts and (4) MS35333-39 lock washers. Prior to installation of the four (4) bolts, apply Loctite 242 or equivalent thread locker to the bolts. Tighten the bolts to 20-25 inch pounds.
- 16.7.6. Perform Task 16-23-07 beginning in step 5.
- 16.7.7. Perform Task 04-24-01 and Task 04-24-06.

16.8. Task 16-23-06 – Removal of Piper PA-32 Link Sensor

- 16.8.1. Shut down aircraft power and disconnect the aircraft battery.
- 16.8.2. Refer to the Vizion PMA Installation Guide PA-32 Appendix G (267) for illustrated parts catalog.
- 16.8.3. The link sensor (8000-177) is located under the rear seat on the right side of the aircraft.
- 16.8.4. Remove the rear seat.
- 16.8.5. Disconnect 6 pin connector from the pitch servo.
- 16.8.6. Remove the AN3 hardware securing the link sensor to the servo arm and PA-28 bellcrank.
- 16.8.7. Remove the link sensor with the link sensor cable.
- 16.8.8. If the link sensor is being replaced immediately, proceed to step 6 of Task 16-23-07. If the link sensor is being removed for repair or service move to the next step.
- 16.8.9. Disconnect the 9 pin connector from the pitch servo.
- 16.8.10. Secure the pitch servo arm so that it cannot interfere with aircraft controls or the PA-32 bellcrank.
- 16.8.11. Replace the rear seat.
- 16.8.12. Reconnect aircraft battery.
- 16.8.13. Parts should now be safely stored until needed for installation.

16.9. Task 13-23-07 – Installation of Piper PA-32 Link Sensor

16.9.1. Shut down aircraft power and disconnect the aircraft battery.

16.9.2. Refer to the Vizion PMA Installation Guide PA-32 Appendix G (267) for illustrated parts catalog.

16.9.3. The link sensor (8000-177) is located under the rear seat on the right side of the aircraft.

16.9.4. Remove the rear seat.

16.9.5. Install large rod end bearings (P/N 2510-052) in the PMA link sensor (P/N 8000-177) as shown in below. Apply blue threadlocker (Loctite 242 or equivalent) to rod ends and torque AN315-4 nuts to 50-70 in-lb. Maintain orientation of large rod end bearings (P/N 2510-052) and hold the link sensor body and extension rod while torquing AN315-4 nuts.

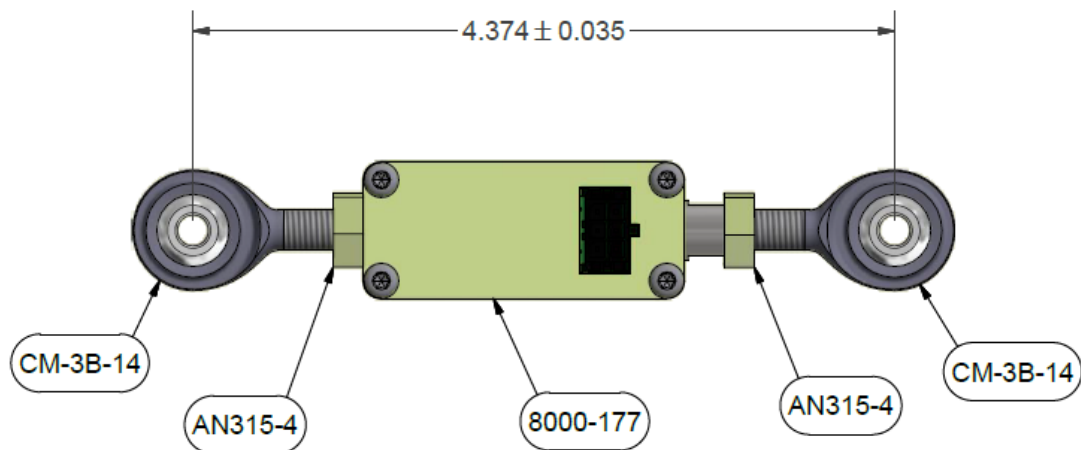

16.9.6. Install the Link Sensor to the servo arm and PA-32 bellcrank as shown below. Tighten fasteners to 20-25 inch pounds.

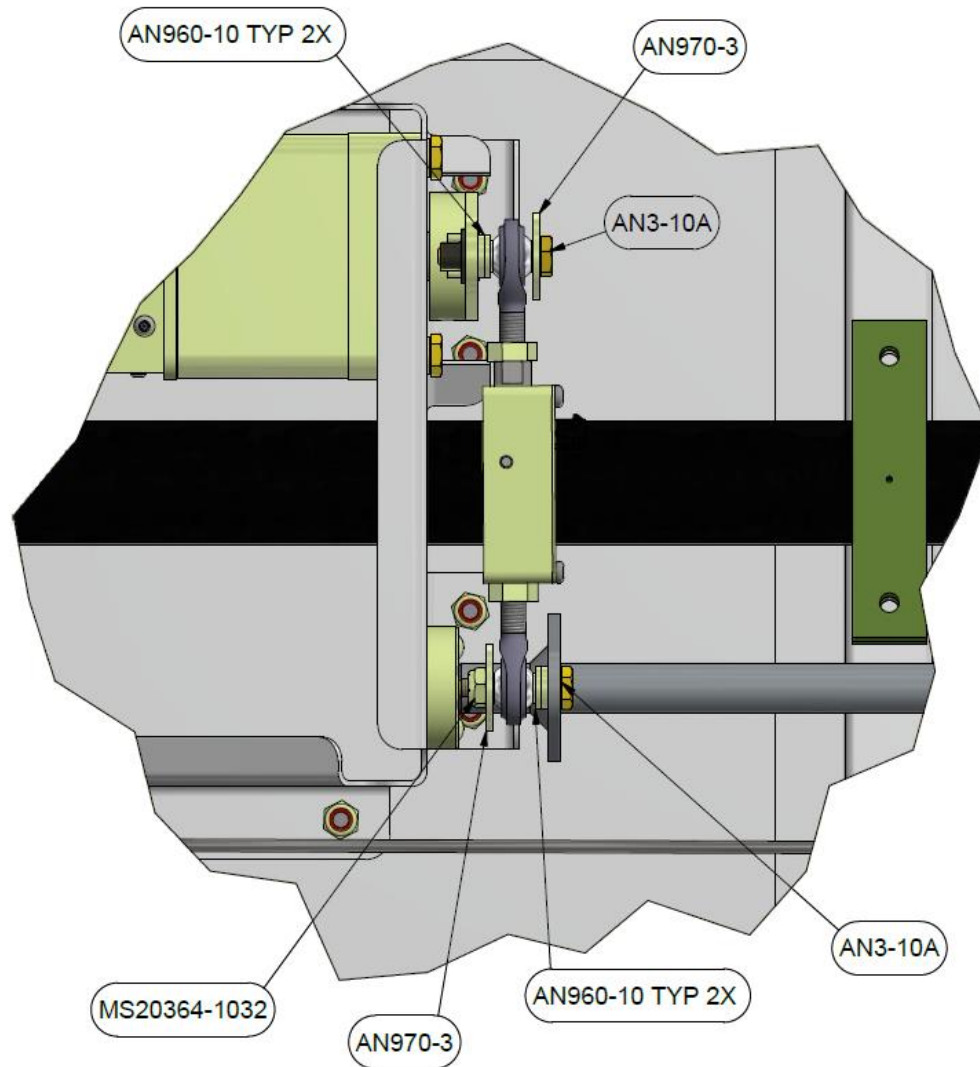

16.9.7. Ensure that the pitch controls move freely throughout full deflection without the servo arm contacting either the forward or aft servo stops.

16.9.8. Connect the 9 pin pitch servo wiring harness to the pitch servo.

16.9.9. Attach the 6 pin link sensor cable to the link sensor.

16.9.10. Attach the 6 pin link sensor cable to the pitch servo.

16.9.11. Ensure the link sensor cable is secured in a fashion that does not place excess strain on the connection to the link sensor and also prevents interference with the aircraft controls.

16.9.12. Replace the rear seat.

16.9.13. Reconnect aircraft battery.

16.9.14. Perform Task 04-24-01, Task 04-24-06, and Task 04-24-07.

TruTrak Flight Systems, Inc.